

**EJX/EJA-E Series
UKEX Certification**

[Option code: /BF21, /BS21,
/BU21, /BS26 and /BN26]



IM 01C25A00-18EN



1. Instructions

This installation manual provides the basic guidelines UKEX certificate of EJX series and EJA-E series.

2. UKEX Certification

(1) Technical Data

a. UKEX Intrinsically safe for HART/BRAIN protocol type (Except for EJX9□0A and output signal -P, -S)

Caution for UKEX Intrinsically safe type.

Note 1. EJX/EJA-E Series pressure transmitters with optional code /BS21 for potentially explosive atmospheres.

- Applicable Standards:
EN IEC 60079-0, EN 60079-11
- Certificate number: DEKRA 23UKEX0132X
- Specific Ex marking:
 II 1 G □ Ex ia IIC T4 Ga
 II 2 D □ Ex ia IIIC T85°C T100°C T120°C Db

- Ambient temperature:
 EPL Ga $-50^{\circ}\text{C} \leq T_a \leq +60^{\circ}\text{C}$
 EPL Db $-30^{\circ}\text{C} \leq T_a \leq +60^{\circ}\text{C}$
 EPL Db* $-15^{\circ}\text{C} \leq T_a \leq +60^{\circ}\text{C}$

- Process temperature:
 EPL Ga $-50^{\circ}\text{C} \leq T_p \leq +120^{\circ}\text{C}$
 EPL Db T120°C $-30^{\circ}\text{C} \leq T_p \leq +120^{\circ}\text{C}$
 T100°C $-30^{\circ}\text{C} \leq T_p \leq +100^{\circ}\text{C}$
 T85°C $-30^{\circ}\text{C} \leq T_p \leq +80^{\circ}\text{C}$
 EPL Db* T120°C $-15^{\circ}\text{C} \leq T_p \leq +120^{\circ}\text{C}$
 T100°C $-15^{\circ}\text{C} \leq T_p \leq +100^{\circ}\text{C}$
 T85°C $-15^{\circ}\text{C} \leq T_p \leq +80^{\circ}\text{C}$

* When FKM O-rings are used. (/HE is specified.)

- Enclosure: IP66/IP67 in accordance with EN IEC 60079-0
- Power supply: $\leq 30\text{ V}$, $\leq 21.6\text{ mA}$
- Dielectric strength:
- 500 V AC, r.m.s., 1 min Terminals: to Enclosure
 Supply +
 Supply –

Note 2. Electrical Parameters: See control drawing

Note 3. Specific conditions of use

When the equipment is mounted in an area where the use of Category 1 G equipment is required, it shall be installed in such a way that, even in the event of rare incidents, an ignition source due to impact and/or friction sparks is excluded.

Precaution shall be taken to minimize the risk from electrostatic discharges or propagating brush discharges on the non-metallic parts (excluding glass parts) or coated parts of the equipment.

The dielectric strength of at least 500 V of the intrinsically safe circuits of the equipment is limited only by the overvoltage protection. From the safety point of view, the intrinsically safe circuit of the equipment shall be assumed to be connected to earth.

Note 4. Installation and erection

When installing the equipment, the selected Type of Protection should be ticked as follows.

- Ex ia IIC T4 Ga
- Ex ia IIIC T85°C T100°C T120°C Db

Cable entry devices suitable for the thread form and the size of the cable entries must be used, according to the following marking on the equipment.

Screw Size	Marking
ISO M20 × 1.5 female	$\triangle M$
ANSI 1/2 NPT female	$\triangle A$ or $\triangle N$ or $\triangle W$

F0239.ai

Note 5. Use and setting-up (operation)

If the equipment is mounted in an area where explosive atmospheres may be present, it must be installed in such a way that the risk from electrostatic discharges and propagating brush discharges caused by rapid flow of dust are avoided.

Note 6. Maintenance and repair



WARNING

A modification of the equipment would no longer comply with the construction described in the certificate documentation.

Only personnel authorized by Yokogawa Electric Corporation can repair the equipment.

Yokogawa Electric Corporation		Model		EJX Series			
Title	Control drawing (General)						
No.	IKE045-A91	Page	1	Revision	0	Date	2020-08-07

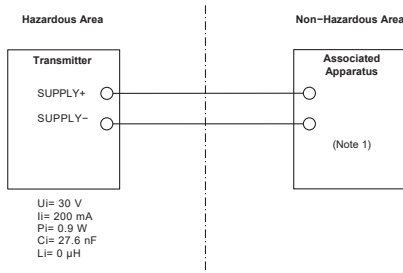

Notes:
1. Associated Apparatus must be a linear power source whose output current is resistively limited.

- Dielectric strength:
- 500 V AC, r.m.s., 1 min Terminals: to Enclosure
Supply +
Supply –

Note 2. Electrical Parameters

Intrinsically safe ratings are as follows:

[Entity]

- Ui = 24 V
- Ii = 250 mA
- Pi = 1.2 W
- Ci = 3.52 nF
- Li = 0 μH

[FISCO IIC]

- Ui = 17.5 V
- Ii = 380 mA
- Pi = 5.32 W
- Ci = 3.52 nF
- Li = 0 μH

[FISCO IIB]

- Ui = 17.5 V
- Ii = 460 mA
- Pi = 5.32 W
- Ci = 3.52 nF
- Li = 0 μH

b. UKEX Intrinsically safe for Fieldbus type (Except for EJX9□0A)

Caution for UKEX Intrinsically safe type.

Note 1. EJX/EJA-E Series pressure transmitters with optional code /BS26 for potentially explosive atmospheres.

- Applicable Standards: EN IEC 60079-0, EN 60079-11
- Certificate number: DEKRA 23UKEX0131X
- Specific Ex marking:



II 1 G □ Ex ia IIC/IIB T4 Ga
II 2 D □ Ex ia IIIC T85°C T100°C T120°C Db

- Ambient temperature:
EPL Ga -55°C ≤ Ta ≤ +60°C
EPL Db -30°C ≤ Ta ≤ +60°C
EPL Db* -15°C ≤ Ta ≤ +60°C
- Process temperature:
EPL Ga -55°C ≤ Tp ≤ +120°C
EPL Db T120°C -30°C ≤ Tp ≤ +120°C
T100°C -30°C ≤ Tp ≤ +100°C
T85°C -30°C ≤ Tp ≤ +80°C
EPL Db* T120°C -15°C ≤ Tp ≤ +120°C
T100°C -15°C ≤ Tp ≤ +100°C
T85°C -15°C ≤ Tp ≤ +80°C

* When FKM O-rings are used. (/HE is specified.)

- Enclosure: IP66/IP67 in accordance with EN IEC 60079-0
- Power supply: ≤ 24 V, ≤ 24 mA

Note 3. Specific conditions of use

When the Pressure Transmitters is made of aluminum, if mounted in an area where the use of Category 1G equipment is required, it shall be installed such that, even in the event of rare incidents, ignition sources due to impact and friction sparks are excluded.

Precautions shall be taken to minimize the risk from electrostatic discharge of painted parts. The dielectric strength of at least 500 V of the intrinsically safe circuits of the Pressure Transmitters is limited only by the overvoltage protection.

Note 4. Installation and erection

When installing the equipment, the selected Type of Protection should be ticked as follows.

- Ex ia IIC/IIB T4 Ga
- Ex ia IIIC T85°C T100°C T120°C Db

Cable entry devices suitable for the thread form and the size of the cable entries must be used, according to the following marking on the equipment.

Screw Size	Marking
ISO M20 × 1.5 female	△ M
ANSI 1/2 NPT female	△ A or △ N or △ W

F0239.ai

Note 5. Use and setting-up (operation)

If the equipment is mounted in an area where explosive atmospheres may be present, it must be installed in such a way that the risk from electrostatic discharges and propagating brush discharges caused by rapid flow of dust are avoided.

Note 6. Maintenance and repair**WARNING**

A modification of the equipment would no longer comply with the construction described in the certificate documentation.

Only personnel authorized by Yokogawa Electric Corporation can repair the equipment.

Model: EJX Series Date: March 31, 2004

Note

- In the rating 1(*1), the output current of the barrier must be limited by a resistor 'Ra' such that $I_o=U_o/R_a$.
- In the rating 2(*2), the output of the barrier must be the characteristics of the trapezoid or the rectangle and this transmitter can be connected to Fieldbus equipment which are in according to the FISCO model.
- The terminators may be built in by a barrier.
- More than one transmitter may be connected to the power supply line.
- The terminator and the safety barrier shall be certified.

Electrical data:

Maximum Input Voltage U_i : 24V	}	*1: Rating 1
Maximum Input Current I_i : 250mA		
Maximum Input Power P_i : 1.2W		
Maximum Internal Capacitance C_i : 4.56nF 3.52nF Δ		
Maximum Internal Inductance L_i : 0 μ H		
or		
Maximum Input Voltage U_i : 17.5V	}	*2: Rating 2
Maximum Input Current I_i : 380mA 380mA Δ		
Maximum Input Power P_i : 6.62W 5.32W Δ		
Maximum Internal Capacitance C_i : 4.56nF 3.52nF Δ		
Maximum Internal Inductance L_i : 0 μ H		
or		
Maximum Input Voltage U_i : 17.5V		
Maximum Input Current I_i : 460mA		
Maximum Input Power P_i : 5.32W		
Maximum Internal Capacitance C_i : 4.56nF 3.52nF Δ		
Maximum Internal Inductance L_i : 0 μ H		

Model: EJX Series Date: March 31, 2004
11.0 Drawings
11.1 Installation Diagram

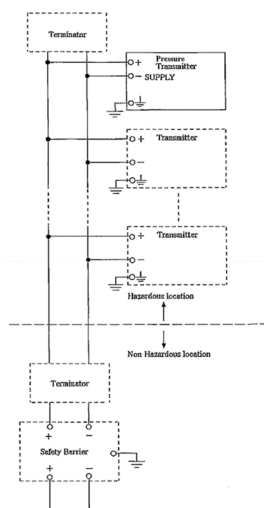

Rev. Doc. No.: IKE022-A12 P.1
Drawing: Y. Takamuku
Approved: K. Masuki
IKE022 Yokogawa Electric Corporation

Rev. Δ July 16, 2004 Y. Takamuku Doc. No.: IKE022-A12 P.2
Rev. 2: October 15, 2011 A. Okada Drawing: Y. Takamuku
Approved: K. Masuki

IKE022 Yokogawa Electric Corporation

c. UKEX Flameproof type (Except for EJX9□0A and Output signal -P, -S)

Caution for UKEX Flameproof type.

Note 1. EJX/EJA-E Series pressure transmitters with optional code /BF21 or /BU21* for potentially explosive atmospheres.

* /BU21: Except for Fieldbus communication type, PROFIBUS PA type, EJX910A, EJX930A

- Applicable Standard: EN IEC 60079-0, EN 60079-1, EN 60079-31
- Certificate number: DEKRA 23UKEX0129X
- Specific Ex marking:

Ex □ II 2 G Ex db IIC T6...T4 Gb
□ II 2 D Ex tb IIIC T85°C Db

- Ambient Temperature for gas:
T6: $-50\text{ °C} \leq T_a \leq +75\text{ °C}$
T5: $-50\text{ °C} \leq T_a \leq +80\text{ °C}$
T4: $-50\text{ °C} \leq T_a \leq +75\text{ °C}$
- Process Temperature for gas:
T6: $-50\text{ °C} \leq T_p \leq +85\text{ °C}$
T5: $-50\text{ °C} \leq T_p \leq +100\text{ °C}$
T4: $-50\text{ °C} \leq T_p \leq +120\text{ °C}$

- Maximum Surface Temperature for dust:
T85 °C (-30* °C ≤ Ta ≤ +75 °C, -30* °C ≤ Tp ≤ +85 °C)
* -15 °C when /HE is specified.
- Enclosure: IP66/IP67

Note 2. Electrical Data

- Supply voltage: 42 V dc max.
32 V dc max. (FOUNDATION Fieldbus and PROFIBUS PA type)
9 to 30 V dc, 250 mW (RS485 Modbus Communication Type)
9 to 28 V dc, 27 mW (Low Power type)
- Output signal: 4 to 20 mA,
15 mA (FOUNDATION Fieldbus and PROFIBUS PA type)
RS485 Modbus (RS485 Modbus Communication Type),
1 to 5 Vdc (Low Power type)

Note 3. Once a device is installed, it should not be re-installed using any other approval types. Apply a permanent mark in the check box of the selected approval type on the certification label on the transmitter to distinguish it from unused approval types.

Note 4. Installation and erection

- Cable glands, adapters and/or blanking elements with a suitable IP rating shall be of Ex db IIC/Ex tb IIIC certified for UKEX and shall be installed so as to maintain the specific degree of protection (IP Code) of the equipment.
- When installing the equipment, the selected Type of Protection should be ticked as follows.
 Ex db IIC T6...T4 Gb
 Ex tb IIIC T85 °C Db
- Cable entry devices suitable for the thread form and the size of the cable entries must be used, according to the following marking on the equipment.

Screw Size	Marking
ISO M20 × 1.5 female	△ M
ANSI 1/2 NPT female	△ N or △ W

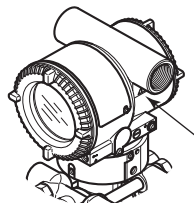

Location of the mark

F0222.ai

- WHEN THE AMBIENT TEMP. ≥ 65 °C, USE HEATRESISTING CABLE AND CABLE GLAND ≥ 90 °C.
- All wiring shall comply with local installation requirement.
- In order to prevent the earthing conductor from loosening, the conductor must be secured to the terminal, tightening the screw with appropriate torque. Care must be taken not to twist the conductor.
- Wiring connection for output signal code Q (Low Power type) shall follow the diagram below.

Pressure Transmitters

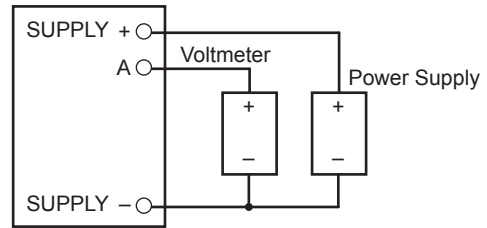

Three-Wire Connection

Pressure Transmitters

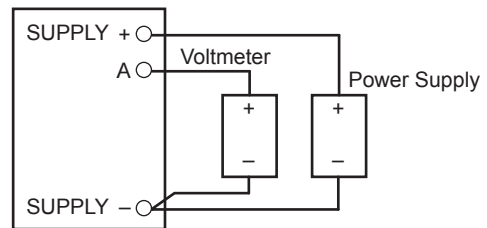

Four-Wire Connection

F0221.ai

Note 5. Use and setting-up (operation)

- POTENTIAL ELECTROSTATIC CHARGING HAZARD Take care not to generate mechanical spark when access to the equipment and the peripheral devices in hazardous locations.
Avoid any actions that cause the generation of electrostatic charge, such as rubbing with a dry cloth on coating face of the product.
- When opening the cover, AFTER DE-ENERGIZING, DELAY 5 MINUTES BEFORE OPENING.

Note 6. Maintenance and Repair

- WARNING:
 - A modification of the equipment would no longer comply with the construction described in the certificate documentation.

- Only personnel authorized by Yokogawa Electric Corporation can repair the equipment in accordance with the relevant standards: IEC/EN 60079-19 (Equipment repair, overhaul and reclamation) and IEC/EN 60079-17 (Electrical installation inspection and maintenance); otherwise the certification will be voided.

Note 7. Specific Conditions of Use

- **WARNING**
 - The flame paths differ from the standard values in EN 60079-1. Repair of the equipment is only allowed when done by the manufacturer or an authorized representative.
 - The property class of the fasteners used to fasten the transmitter enclosure onto the sensor capsule is at least A2-50 or A4-50.
 - For transmitters with a membrane made of titanium, ignition hazard due to impact and friction on the membranes shall be avoided.

d. UKEX Flameproof type for EJX9□0A

Caution for UKEX Flameproof type.

Note 1. EJX Series pressure transmitters with optional code /BF21 for potentially explosive atmospheres.

- Applicable Standard: EN IEC 60079-0, EN 60079-1, EN 60079-31
- Certificate number: DEKRA 23UKEX0129X
- Specific Ex marking:
 - II 2 G Ex db IIC T6...T4 Gb
 - II 2 D Ex tb IIIC T85°C Db
- Ambient Temperature for gas:
 - T6: $-50\text{ °C} \leq T_a \leq +75\text{ °C}$
 - T5: $-50\text{ °C} \leq T_a \leq +80\text{ °C}$
 - T4: $-50\text{ °C} \leq T_a \leq +75\text{ °C}$
- Process Temperature for gas:
 - T6: $-50\text{ °C} \leq T_p \leq +85\text{ °C}$
 - T5: $-50\text{ °C} \leq T_p \leq +100\text{ °C}$
 - T4: $-50\text{ °C} \leq T_p \leq +120\text{ °C}$
- Maximum Surface Temperature for dust:
 - T85°C ($-30\text{ °C} \leq T_a \leq +75\text{ °C}$, $-30\text{ °C} \leq T_p \leq +85\text{ °C}$)
 - * -15 °C when /HE is specified.
- Enclosure: IP66/IP67

Note 2. Electrical Data

- Supply voltage: 42 V dc max. 32 V dc max. (FOUNDATION Fieldbus type) 9 to 30 V dc, 250 mW (RS485 Modbus Communication Type)
- Output signal: 4 to 20 mA, 15 mA (FOUNDATION Fieldbus type) RS485 Modbus (RS485 Modbus Communication Type)

Note 3. Once a device is installed, it should not be re-installed using any other approval types. Apply a permanent mark in the check box of the selected approval type on the certification label on the transmitter to distinguish it from unused approval types.

Note 4. Installation and erection

- Cable glands, adapters and/or blanking elements with a suitable IP rating shall be of Ex db IIC/Ex tb IIIC certified for UKEX and shall be installed so as to maintain the specific degree of protection (IP Code) of the equipment.
- When installing the equipment, the selected Type of Protection should be ticked as follows.
 - Ex db IIC T6...T4 Gb
 - Ex tb IIIC T85 °C Db
- Cable entry devices suitable for the thread form and the size of the cable entries must be used, according to the following marking on the equipment.

Screw Size	Marking
ISO M20 × 1.5 female	△ M
ANSI 1/2 NPT female	△ N or △ W

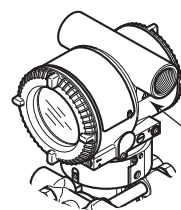

Location of the mark

F0222.ai

- WHEN THE AMBIENT TEMP. $\geq 65\text{ °C}$, USE HEATRESISTING CABLE AND CABLE GLAND $\geq 90\text{ °C}$.
- All wiring shall comply with local installation requirement.
- In order to prevent the earthing conductor from loosening, the conductor must be secured to the terminal, tightening the screw with appropriate torque. Care must be taken not to twist the conductor.

Note 5. Use and setting-up (operation)

- POTENTIAL ELECTROSTATIC CHARGING HAZARD Take care not to generate mechanical spark when access to the equipment and the peripheral devices in hazardous locations.
Avoid any actions that cause the generation of electrostatic charge, such as rubbing with a dry cloth on coating face of the product.
- When opening the cover, AFTER DE-ENERGIZING, DELAY 5 MINUTES BEFORE OPENING.

Note 6. Maintenance and Repair

- WARNING:
 - A modification of the equipment would no longer comply with the construction described in the certificate documentation.
 - Only personnel authorized by Yokogawa Electric Corporation can repair the equipment. in accordance with the relevant standards: IEC/EN 60079-19 (Equipment repair, overhaul and reclamation) and IEC/EN 60079-17 (Electrical installation inspection and maintenance); otherwise the certification will be voided.

Note 7. Specific Conditions of Use

- WARNING
 - The flame paths differ from the standard values in EN 60079-1. Repair of the equipment is only allowed when done by the manufacturer or an authorized representative.
 - The property class of the fasteners used to fasten the transmitter enclosure onto the sensor capsule is at least A2-50 or A4-50.
 - For transmitters with a membrane made of titanium, ignition hazard due to impact and friction on the membranes shall be avoided.

e. UKEX Flameproof type for Output signal -P, -S

Caution for UKEX Flameproof type.

Note 1. EJX/EJA-E Series pressure transmitters with optional code /BF21 for potentially explosive atmospheres.

- Applicable Standard: EN IEC 60079-0, EN 60079-1, EN 60079-31
- Certificate number: DEKRA 23UKEX0129X
- Specific Ex marking:

 II 2 G Ex db IIC T6...T4 Gb
 II 2 D Ex tb IIIC T85°C Db

- Ambient Temperature for gas:
 - T6: $-50\text{ °C} \leq T_a \leq +75\text{ °C}$
 - T5: $-50\text{ °C} \leq T_a \leq +80\text{ °C}$
 - T4: $-50\text{ °C} \leq T_a \leq +75\text{ °C}$
- Process Temperature for gas:
 - T6: $-50\text{ °C} \leq T_p \leq +85\text{ °C}$
 - T5: $-50\text{ °C} \leq T_p \leq +100\text{ °C}$
 - T4: $-50\text{ °C} \leq T_p \leq +120\text{ °C}$
- Maximum Surface Temperature for dust:
 - T85°C ($-30^*\text{ °C} \leq T_a \leq +75\text{ °C}$, $-30^*\text{ °C} \leq T_p \leq +85\text{ °C}$)
 - * -15 °C when /HE is specified.
- Enclosure: IP66/IP67

Note 2. Electrical Data

- Supply voltage: 42 V dc max.
- Output signal: 4 to 20 mA, A slave pressure transmitter, Type EJ* *-S, is only to be connected to a pressure transmitter with master slave connections, Type EJ* *-P, for power supply and communication by a 4 wire connection.

Note 3. Once a device is installed, it should not be re-installed using any other approval types. Apply a permanent mark in the check box of the selected approval type on the certification label on the transmitter to distinguish it from unused approval types.

Note 4. Installation and erection

- Cable glands, adapters and/or blanking elements with a suitable IP rating shall be of Ex db IIC/Ex tb IIIC certified for UKEX and shall be installed so as to maintain the specific degree of protection (IP Code) of the equipment.
- When installing the equipment, the selected Type of Protection should be ticked as follows.
 - Ex db IIC T6...T4 Gb
 - Ex tb IIIC T85 °C Db

- Cable entry devices suitable for the thread form and the size of the cable entries must be used, according to the following marking on the equipment.

Screw Size	Marking
ISO M20 × 1.5 female	△ M
ANSI 1/2 NPT female	△ N or △ W

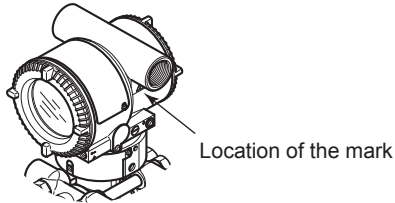

F0222.ai

- WHEN THE AMBIENT TEMP. $\geq 65^{\circ}\text{C}$, USE HEATRESISTING CABLE AND CABLE GLAND $\geq 90^{\circ}\text{C}$.
- All wiring shall comply with local installation requirement.
- In order to prevent the earthing conductor from loosening, the conductor must be secured to the terminal, tightening the screw with appropriate torque. Care must be taken not to twist the conductor.
- Wiring connection shall follow the diagram below.

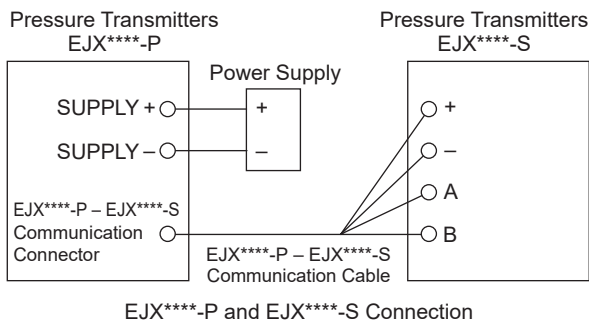

F0204.ai

Note 5. Use and setting-up (operation)

- **POTENTIAL ELECTROSTATIC CHARGING HAZARD** Take care not to generate mechanical spark when access to the equipment and the peripheral devices in hazardous locations. Avoid any actions that cause the generation of electrostatic charge, such as rubbing with a dry cloth on coating face of the product.
- When opening the cover, **AFTER DE-ENERGIZING, DELAY 10 MINUTES BEFORE OPENING.**

Note 6. Maintenance and Repair

- **WARNING:**
 - A modification of the equipment would no longer comply with the construction described in the certificate documentation.
 - Only personnel authorized by Yokogawa Electric Corporation can repair the equipment. in accordance with the relevant standards: IEC/EN 60079-19 (Equipment repair, overhaul and reclamation) and IEC/EN 60079-17 (Electrical installation inspection and maintenance); otherwise the certification will be voided.

Note 7. Specific Conditions of Use

- **WARNING**
 - The flame paths differ from the standard values in EN 60079-1. Repair of the equipment is only allowed when done by the manufacturer or an authorized representative.
 - The property class of the fasteners used to fasten the transmitter enclosure onto the sensor capsule is at least A2-50 or A4-50.
 - For transmitters with a membrane made of titanium, ignition hazard due to impact and friction on the membranes shall be avoided.

f. UKEX Intrinsically safe and Flameproof for HART/BRAIN protocol type (Except for EJX9□0A and Output signal -P, -S)

EJX/EJA-E Series pressure transmitters with optional code /BU21 can be selected the type of protection UKEX Flameproof, Intrinsically safe. Ex ia, or Ex ic for potentially explosive atmospheres.

Note 1. For the installation of this transmitter,

once a particular type of protection is selected, any other type of protection cannot be used. The installation must be in accordance with the description about the type of protection in this user's manual.

Note 2. For combined approval types

Once a device of multiple approval type is installed, it should not be re-installed using any other approval types. Apply a permanent mark in the check box of the selected approval type on the certification label on the transmitter to distinguish it from unused approval types.

• UKEX Intrinsicly safe Ex ic

Caution for UKEX Intrinsicly safe Ex ic.

- Applicable Standards: EN IEC 60079-0, EN 60079-11
- Specific Ex marking:
 Ex II 3 G □ Ex ic IIC T4 Gc
- Ambient temperature:
 $-30^{\circ}\text{C} \leq T_a \leq +60^{\circ}\text{C}$
 $-15^{\circ}\text{C} \leq T_a \leq +60^{\circ}\text{C}^*$
- Process temperature:
 $-30^{\circ}\text{C} \leq T_p \leq +120^{\circ}\text{C}$
 $-15^{\circ}\text{C} \leq T_p \leq +120^{\circ}\text{C}^*$
 * When FKM O-rings are used. (/HE is specified.)
- Enclosure: IP66
- Pollution degree: 2
- Overvoltage category: I
- Power supply: $\leq 30\text{ V}$, $\leq 21.6\text{ mA}$
- Dielectric strength
- 500 V AC, r.m.s., 1 min Terminals: to Enclosure
 Supply +
 Supply –

- Specific conditions of use:
 Precaution shall be taken to minimize the risk from electrostatic discharges on the non-metallic parts (excluding glass parts) or coated parts of the equipment.
 The dielectric strength of at least 500 V of the intrinsicly safe circuits of the equipment is limited only by the overvoltage protection. From the safety point of view, the intrinsicly safe circuit of the equipment shall be assumed to be connected to earth.
- Installation and erection:
 Cable entry devices suitable for the thread form and the size of the cable entries must be used, according to the following marking on the equipment.

Screw Size	Marking
ISO M20 × 1.5 female	Δ M
ANSI 1/2 NPT female	Δ A or Δ N or Δ W

F0239.ai

When installing the equipment, the selected Type of Protection should be ticked as follows.

- Ex ic IIC T4 Gc
- Ex ia IIC T4 Ga

- Use and setting-up (operation):
 If the pressure transmitter is mounted in an area where explosive atmospheres may be present, it must be installed in such a way that the risk from electrostatic discharges.

- Maintenance and repair



WARNING

A modification of the equipment would no longer comply with the construction described in the certificate documentation.

Only personnel authorized by Yokogawa Electric Corporation can repair the equipment.

Yokogawa Electric Corporation		Model	EJX Series		
Title	Control drawing	Prepared by	M. Inatomi		
No.	IKE046-A70	Approved by	D. Harada		
Revised pages	1-2	Page	1	Revision	2
		Date	2020-09-02		

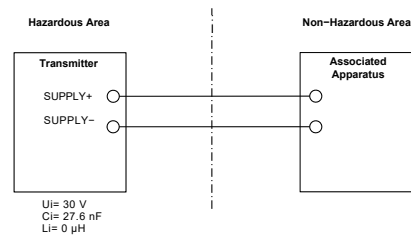

g. UKEX Intrinsicly safe Ex ic for Fieldbus type (Except for EJX9□0A)

Caution for UKEX Intrinsicly safe Ex ic.

Note 1. The transmitters with option code /BN26 for potentially explosive atmospheres.

- Applicable Standards: EN IEC 60079-0, EN 60079-11
- Specific Ex marking:
 Ex II 3 G Ex ic IIC T4 Gc
- Ambient temperature:
 $-30^{\circ}\text{C} \leq T_a \leq +60^{\circ}\text{C}$
 $-15^{\circ}\text{C} \leq T_a \leq +60^{\circ}\text{C}^*$
- Process temperature:
 $-30^{\circ}\text{C} \leq T_p \leq +120^{\circ}\text{C}$
 $-15^{\circ}\text{C} \leq T_p \leq +120^{\circ}\text{C}^*$
 * When FKM O-rings are used. (/HE is specified.)
- Enclosure: IP66
- Pollution degree: 2
- Overvoltage category: I
- Power supply: $\leq 32\text{ V}$, $\leq 24\text{ mA}$
- Dielectric strength
- 500 V AC, r.m.s., 1 min Terminals: to Enclosure
 Supply +
 Supply –

Note 2. Electrical Parameters: See control drawing

Note 3. Specific conditions of use

Precaution shall be taken to minimize the risk from electrostatic discharges on the non-metallic parts (excluding glass parts) or coated parts of the equipment.

The dielectric strength of at least 500 V of the intrinsically safe circuits of the equipment is limited only by the overvoltage protection. From the safety point of view, the intrinsically safe circuit of the equipment shall be assumed to be connected to earth.

Note 4. Installation and erection

Cable entry devices suitable for the thread form and the size of the cable entries must be used, according to the following marking on the equipment.

Screw Size	Marking
ISO M20 × 1.5 female	⚠ M
ANSI 1/2 NPT female	⚠ A or ⚠ N or ⚠ W

F0239.ai

Note 5. Use and setting-up (operation)

If the pressure transmitter is mounted in an area where explosive atmospheres may be present, it must be installed in such a way that the risk from electrostatic discharges.

Note 6. Maintenance and repair



WARNING

A modification of the equipment would no longer comply with the construction described in the certificate documentation.

Only personnel authorized by Yokogawa Electric Corporation can repair the equipment.

Note 7. Control drawing

Model: EJX Series Date: February 28, 2013

14 Control Drawing

Following instructions shall be included in the user's manual, together with the following items:

- a list of the standards in 1, including the issue year;
- specifications in 2;
- marking information in 13.

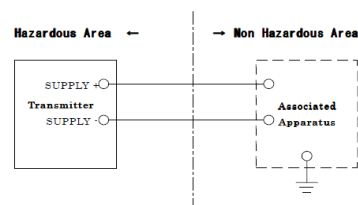

Electrical data are as follows:

$U_i = 32 \text{ V}$
 $C_i = 3.52 \text{ nF}$
 $L_i = 0 \text{ pH}$

Specific Conditions of Use:

· Precautions shall be taken to minimize the risk from electrostatic discharge of painted parts.

· The dielectric strength of at least 500 V a.c. r.m.s between the intrinsically safe circuits and the enclosure of the Pressure Transmitter Model EJX Series, Model EJA***E Series and Model EJA***J Series are limited only by the overvoltage protection.

WARNING:

POTENTIAL ELECTROSTATIC CHARGING HAZARD · SEE USER'S MANUAL

Note:

· Cable glands, adapters and/or blanking elements shall be of type "m", type "e" or type "d" and shall be installed so as to maintain the specified degree of protection (IP Code) of the equipment.

Rev.

Doc. No.: IHE047A70
 Drawing: T.Itoa
 Approved: A.Matsunaga

(2) Electrical Connection

A mark indicating the electrical connection type is stamped near the electrical connection port.

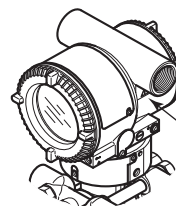

Location of the mark

F0214.ai

(3) Name Plate

• Name plate

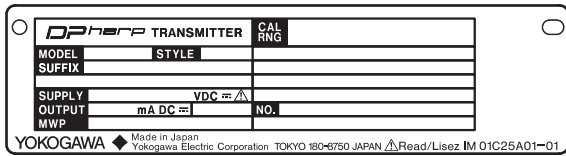

• Tag plate for Flameproof type except for Output signal -P, -S

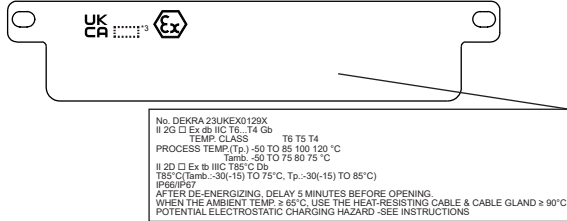

• Tag plate for Flameproof type for Output signal -P, -S

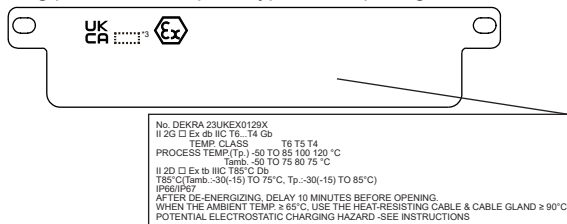

• Tag plate for Intrinsically safe Ex ia for HART/BRAIN

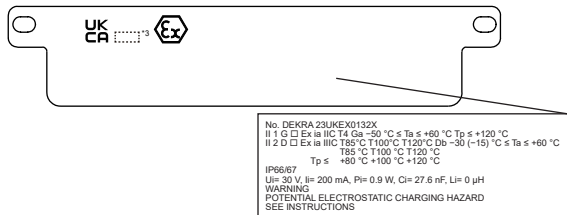

• Tag plate for Intrinsically safe or flameproof for HART/BRAIN

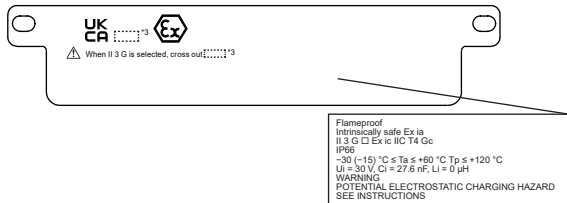

• Tag plate for Intrinsically safe Ex ia for Fieldbus

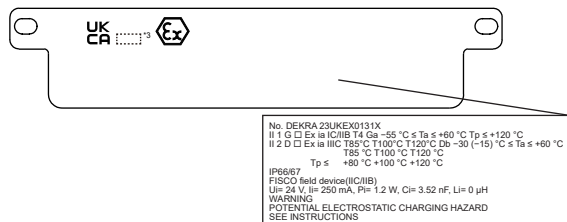

• Tag plate for Intrinsically safe Ex ic for Fieldbus

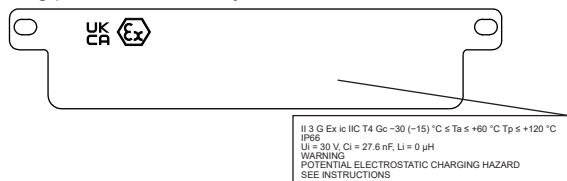

MODEL: Specified model code.
 STYLE: Style code.
 SUFFIX: Specified suffix code.
 SUPPLY: Supply voltage.
 OUTPUT: Output signal.
 MWP: Maximum working pressure.
 CAL RNG: Specified calibration range.
 NO.: Serial number and year of production (*1).
 TOKYO 180-8750 JAPAN:
 The manufacturer name and the address (*2).

*1: The first number in the second block of "NO." column is the last one number of the production year.

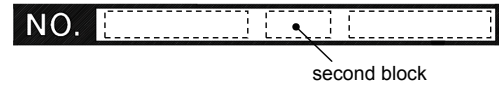

NO. 91K819857 132 7
 The year 2011

*2: "180-8750" is a zip code which represents the following address.

2-9-32 Nakacho, Musashino-shi, Tokyo Japan

*3: The identification number of Approved Body.

Revision Record

Edition	Data	Revised Item
1st	Apr. 2024	New Publication.