

SQM4 Series

SQM4 Actuators for Air and Gas Dampers



Actuator SQM4

Features

- NEMA4 enclosure
- High resolution, electronic actuator
- 35 to 133 in-lb versions
- Clockwise and counterclockwise rotation versions
- Line voltage and analog control versions
- Clearly marked, adjustable limit and auxiliary switches
- Zero & span adjustment on analog versions
- Multiple shaft options
- UL and CSA approved

The SQM40 / SQM41 and this Data Sheet are intended for use by OEMs which integrate the actuators in their products!

Use

The SQM40 / SQM41 actuators are suited for driving butterfly valves and dampers, or for use on other applications that require rotary motion. The actuators are used primarily for load-dependent control of the flow of gas, oil, and/or combustion air. They are controlled in connection with 3-position or modulating controllers (e.g. 4...20 mA) and/or directly by burner controls.

Warning notes

To avoid injury to persons and damage to property or the environment, the following warning notes must be observed!

Only qualified personnel may open, interfere with, or modify the actuators!

- Read the documentation on the actuators carefully and fully. If not observed, dangerous situations might occur
- The user must ensure that the actuators meet the requirements of the relevant application standards
- Safety-related applications are only available with Siemens burner controls
- All product-related activities (mounting, settings, and maintenance) must be performed by qualified and authorized personnel



CAUTION:

- Risk of electric shock hazard – to disconnect the actuator from power, it may be necessary to open more than one switch. Before performing maintenance work, the actuator must be disconnected from power
 - Conduit does not provide grounding. A separate ground wire must be used.
 - All cam switch settings must satisfy the requirements of the relevant application standards
- To provide protection against electric shock hazard, the connecting terminals must have adequate touch protection. Make certain that non-insulated connections or wires cannot be touched
 - Each time work has been carried out (mounting, installation, service work, etc.), check to ensure that wiring is in an orderly state
 - Fall or shock can adversely affect the safety functions. Such actuators must not be put into operation even if they do not exhibit any damage
 - Static charges must be avoided since they can damage the actuator's electronic components when touched

Recommendation: Use ESD equipment

Notes for use in North America

- Use of flexible conduit with proper fittings is required
- Use copper wiring
- Wiring must comply with all local and national codes

Mounting notes

- Ensure that the relevant national safety regulations and notes on standards are complied with
- Required tightening torques for the fixing screws of the
 - housing cover: 30 in-lb
 - connecting cover: 18 in-lb
- To ensure degree of protection IP66, the user must fit suitable glands or plugs on the connector cover on the actuator. To ensure degree of protection IP66 throughout the lifetime of the actuator, the bearing of the actuator drive shaft must be located somewhere it will not be directly exposed to water or dust

**NOTE:**

Ensure correct direction of rotation!

Installation notes

- Make certain that strain relief of the connected cables conforms to the relevant standards
- Ensure that spliced wires cannot get into contact with neighboring terminals. Use adequate ferrules
- Unused terminals of the SQM40 / SQM41 must be covered by dummy plugs
- When wiring, the AC 120 V section must be separated from other voltage sections, thus ensuring protection against electric shock hazard
- The connection between the actuator drive shaft and the relevant controlling element must be secure
- Metal conduit fittings may be used

Electrical connection

- The actuator's 'L1' connection must always be protected via a slow-blow fuse - max 6.3 A
- For the protective earth connection, the housing of all variants has a marked **PE** connecting terminal. A tightening torque of 10.6 in-lbs must be observed for tightening the screw
- The supplied RAST3.5 connectors or RAST5 connectors must be used with screw terminals for electrical connections. A tightening torque of 2.2 in-lbs must be observed for tightening the screws

**NOTE:**

SELV or PELV depends on the safety class of the connected components. In the case of PELV, the relevant component is connected to protective earth.

Cam settings

When the actuator is disconnected from power, the cam switches can be adjusted via a scale. The cams are changed via adjusting screws. The scale indicates the position of the switching points.

Standards and certificates



Applied directives:

- Low-voltage directive 2006/95/EC
- Electromagnetic compatibility EMC (immunity) *) 2004/108/EC

*) The compliance with EMC emissions requirements must be checked after the actuator has been installed in the work equipment.

Compliance with the regulations of the applied directives is verified by the adherence to the following standards / regulations:

- Automatic electrical controls for household and similar use Part 2-14: Special requirements on electric actuators DIN EN 60730-2-14
- Automatic electrical controls for household and similar use Part 1: General requirements DIN EN 60730-1



EAC Conformity mark (Eurasian Conformity mark)



China RoHS

Hazardous substances table:

<http://www.siemens.com/download?A6V10883536>



For types marked with **R**

Example: SQM40.264**R**10

- For use in US/Canada where the power supply lines require a connection facility for flexible conduit, the actuator's product no. includes type suffix «R» (see following example). These products are **UL**-listed.



For types marked with **36** or **38**

Examples: SQM4x.36xA2x, SQM4x.38xA2x

For marine applications, environmental category A.

Lifetime

The actuator has a designed lifetime* of 250,000 start cycles (close ⇒ open ⇒ close) under load with the properly rated torque value throughout the entire range of rotation. This lifetime is based on the endurance tests specified in standard EN 298. A summary of the conditions has been published by the European Control Manufacturers Association (Afecor - www.afecor.org).

* The designed lifetime is not the warranty time specified in the Terms of Delivery.

Disposal notes

The SQM40/SQM41 contains electrical and electronic components and must not be disposed of together with domestic waste. Local and currently valid legislation must be observed.

Mechanical design

- Housing
 - Lower housing made of die-cast aluminum
 - NEMA4 housing cover made of impact-proof and heat-resistant plastic
- Drive motor
 - Synchronous motor
- Gear train
 - Shaft can be manually disengaged from the motor by pressing coupling pin K1
 - Automatic reengagement

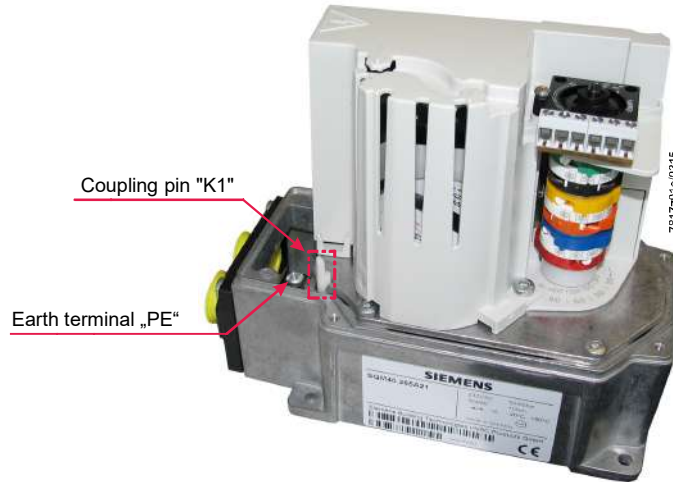

- Earth connection
 - Earth terminal “PE” with screw fitting
- Adjustment of switch settings
 - With adjustable cams
 - Scales beside the cams indicate the position of the switch settings
- Electrical connections
 - RAST3.5 screw terminals are factory supplied, depending on the PCB variant
 - RAST5 screw terminals are factory supplied, depending on the PCB variant
 - Cable entry by means of 2 openings in the connector cover supplied
- Gear train
 - Maintenance-free gears and bearings
- Drive shaft
 - Different shaft versions available
 - Drive shaft is not replaceable
 - Rotation direction cannot be reversed
- Actuator mounting
 - No mounting position restrictions. All mounting orientations are allowed. Clearance holes at the corners of the housing for #8, #10, or M5 screws, or blind holes around the shaft for M5 self-tapping screws. See Dimensions for additional info.

Part Numbers (other part numbers on request)

Article no.	Part Number	Direction of rotation		Torque ¹⁾ / running time ¹⁾ for 90° / 60 Hz	PCB				Shaft no.	Operating voltage	Potentiometer	
		Counter-clockwise	Clockwise		Board #	3-position	2-position	No. of switches			Double 90°	Double 135°
BPZ:SQM40.115R11	SQM40.115R11	●		35 in-lb / 12.5 s	1			3	5	AC 120 V	●	
BPZ:SQM40.115R13	SQM40.115R13	●		35 in-lb / 12.5 s	1			3	5	AC 120 V		●
BPZ:SQM40.144R11	SQM40.144R11	●		35 in-lb / 12.5 s	4			3	4	AC 120 V	●	
BPZ:SQM40.155R11	SQM40.155R11	●		35 in-lb / 12.5 s	5			4	5	AC 120 V	●	
BPZ:SQM40.155R13	SQM40.155R13	●		35 in-lb / 12.5 s	5			4	5	AC 120 V		●
BPZ:SQM40.165R11	SQM40.165R11	●		35 in-lb / 12.5 s	6	●		6	5	AC 120 V	●	
BPZ:SQM40.185R11	SQM40.185R11	●		35 in-lb / 12.5 s	8	●		6	5	AC 120 V	●	
BPZ:SQM40.215R11	SQM40.215R11	●		75 in-lb / 25 s	1			3	5	AC 120 V	●	
BPZ:SQM40.215R13	SQM40.215R13	●		75 in-lb / 25 s	1			3	5	AC 120 V		●
BPZ:SQM40.241R11	SQM40.241R11	●		75 in-lb / 25 s	4			3	1	AC 120 V	●	
BPZ:SQM40.244R11	SQM40.244R11	●		75 in-lb / 25 s	4			3	4	AC 120 V	●	
BPZ:SQM40.255R11	SQM40.255R11	●		75 in-lb / 25 s	5			4	5	AC 120 V	●	
BPZ:SQM40.255R13	SQM40.255R13	●		75 in-lb / 25 s	5			4	5	AC 120 V		●
BPZ:SQM40.261R11	SQM40.261R11	●		75 in-lb / 25 s	6	●		6	1	AC 120 V	●	
BPZ:SQM40.265R11	SQM40.265R11	●		75 in-lb / 25 s	6	●		6	5	AC 120 V	●	
BPZ:SQM40.274R10	SQM40.274R10	●		75 in-lb / 25 s	7		●	5	4	AC 120 V		
BPZ:SQM40.275R10	SQM40.275R10	●		75 in-lb / 25 s	7		●	5	5	AC 120 V		
BPZ:SQM40.285R11	SQM40.285R11	●		75 in-lb / 25 s	8	●		6	5	AC 120 V	●	
BPZ:SQM40.317R11	SQM40.317R11	●		133 in-lb / 54 s	1			3	7	AC 120 V	●	
BPZ:SQM40.317R13	SQM40.317R13	●		133 in-lb / 54 s	1			3	7	AC 120 V		●

Article no.	Part Number	Direction of rotation		Torque ¹⁾ / running time ¹⁾ for 90° / 60 Hz	PCB				Shaft no.	Operating voltage	Potentiometer	
		Counter-clockwise	Clockwise		Board #	3-position	2-position	No. of switches			Double 90°	Double 135°
BPZ:SQM40.357R11	SQM40.357R11	●		133 in-lb / 54 s	5			4	7	AC 120 V	●	
BPZ:SQM40.357R13	SQM40.357R13	●		133 in-lb / 54 s	5			4	7	AC 120 V		●
BPZ:SQM40.387R11	SQM40.387R11	●		133 in-lb / 54 s	8	●		6	7	AC 120 V	●	
BPZ:SQM41.165R11	SQM41.165R11		●	35 in-lb / 12.5 s	6	●		6	5	AC 120 V	●	
BPZ:SQM41.185R11	SQM41.185R11		●	35 in-lb / 12.5 s	8	●		6	5	AC 120 V	●	
S55452-D307-A100	SQM41.215R13		●	75 in-lb / 25 s	1			3	5	AC 120 V		●
BPZ:SQM41.241R11	SQM41.241R11		●	75 in-lb / 25 s	4			3	1	AC 120 V	●	
BPZ:SQM41.244R11	SQM41.244R11		●	75 in-lb / 25 s	4			3	4	AC 120 V	●	
BPZ:SQM41.254R11	SQM41.254R11		●	75 in-lb / 25 s	5			4	4	AC 120 V	●	
BPZ:SQM41.261R11	SQM41.261R11		●	75 in-lb / 25 s	6	●		6	1	AC 120 V	●	
BPZ:SQM41.264R11	SQM41.264R11		●	75 in-lb / 25 s	6	●		6	4	AC 120 V	●	
BPZ:SQM41.265R11	SQM41.265R11		●	75 in-lb / 25 s	6	●		6	5	AC 120 V	●	
BPZ:SQM41.271R10	SQM41.271R10		●	75 in-lb / 25 s	7		●	5	1	AC 120 V		
BPZ:SQM41.275R10	SQM41.275R10		●	75 in-lb / 25 s	7		●	5	5	AC 120 V		
BPZ:SQM41.285R11	SQM41.285R11		●	75 in-lb / 25 s	8	●		6	5	AC 120 V	●	
BPZ:SQM41.357R11	SQM41.357R11		●	133 in-lb / 54 s	5			4	7	AC 120 V	●	
BPZ:SQM41.387R11	SQM41.387R11		●	133 in-lb / 54 s	8	●		6	7	AC 120 V	●	

1) Specifications apply to ambient temperatures of 15 °F, a main voltage of AC 120 V, and a main frequency of 60 Hz. With a main frequency of 50 Hz, the running times are approx. 20% longer. Torques increase by the same rate.

**NOTE:**

Not all types of actuators are kept in stock. Additional versions are available on request.

Drive shafts:

Type of drive shaft	Max. torque	Shaft no.
Ø 10 mm, woodruff key as per DIN 6888	90 in-lb	1
□ 3/8" (9.5 mm), square shaft	130 in-lb	4
Ø 10 mm D type shaft	90 in-lb	5
Ø 14 mm with parallel key as per DIN 6885	180 in-lb	7

Accessories

Replacement parts must be ordered as separate items
 Included with new actuators.



Proportional controlling element with mounting plate **VKPx**
 Proportional controlling element for mounting between threaded flanges in gas trains.
 Refer to data sheet N7632.



Butterfly valve **VKF1x**
 Butterfly valves designed in intermediate flange design, for mounting into gas trains.
 Refer to Data Sheet N7673.



Mounting plate **ASK33.1**
Article no.: **BPZ:ASK33.1**
 For mounting the SQM40.xx5xxx on the VKP proportional controlling element or on
 the VKF1x butterfly valve.



NOTE:
 The required screws (3x M5 countersunk screws and 4x M5 screws) are
 included in the packaging for the ASK33.1.



Front cover (on request)
 For making the connections for the power supply lines
 - For 1/2" NPT protective sleeve **AGA45.11**
Article no. **BPZ:AGA45.11**
 - For metric cable gland **AGA45.12**
Article no. **BPZ:AGA45.12**



NOTE:
 Front covers AGA45.11 and AGA45.12 are only to be used as replacements.
 The corresponding AGA45 version is factory-prefitted onto the SQM40 /
 SQM41.

Accessories

Replacement parts must be ordered as separate items



Connector sets (on request)

With screw terminals for replacement:

- For SQM4x.x1xxxx

AGA45.1

Article no. **BPZ:AGA45.1**

- For SQM4x.x2xxxx, SQM4x.x5xxxx

AGA45.5

Article no. **BPZ:AGA45.5**

- For SQM4x.x3xxxx, SQM4x.x6xxxx, SQM4x.x7xxxx, SQM4x.x8xxxx

AGA45.6

Article no. **BPZ:AGA45.6**



Potentiometers

For retrofitting

- For SQM40 / SQM41: Double potentiometer 2*1000 Ω , 90°

ASZ22.32

Article no.: **S55852-Z301-A100**

- For SQM40: Double potentiometer 2*1000 Ω , 135°

ASZ22.35

Article no.: **S55852-Z303-A100**

- For SQM41: Double potentiometer 2*1000 Ω , 135°

ASZ22.34

Article no.: **S55852-Z302-A100**

Refer to Data Sheet N7921.



NOTE:

ASZ22.3x potentiometers are only intended for the retrofitting onto SQM40 / SQM41 types with the end number 0 (SQM4x.xxxx0).

For all SQM40/SQM41 types with the end number 1 (SQM4x.xxxx1) or 3 (SQM4x.xxxx3), the potentiometers are factory installed.

Accessories

Accessories must be ordered as separate items:

CA...



A crank arm kit can be added to any SQM4x actuator for use with a linkage system. For more information, see Document CPBK-8000.

Cxx...



A coupling can be used to connect the SQM4x actuator to a wide variety of valves and dampers. There are numerous coupling combinations available. For more information, see Document CPBK-1000.

AGA57.5

Article no. **BPZ:AGA57.5**

Bracket for replacing a Honeywell MOD III or IV actuator with any SQM4x actuator.

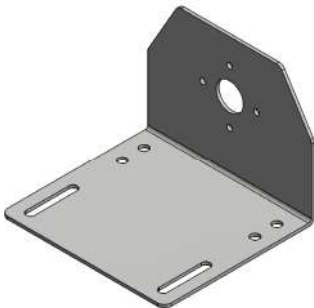

Technical Data

General unit data

Operating voltage	AC 120 V -15%/+10%
Operating frequency	50...60 Hz ±6%
Drive motor	Synchronous motor
Power consumption	10 VA
Duty cycle	100%
Operating angle	Between 0° and max. 90° or between 0° and max. 135°, depending on the type
Mounting position	Any; unrestricted
Degree of protection	IP66, NEMA4, provided adequate cable entries are used
Safety class	I
Mode of action	Automatic control device and control unit, type 2B
External overload fuse	Max. 6.3 A (slow) to DIN EN 60127-2/5
Internal overload fuse	2 A (slow), depending on the type, non-exchangeable
Cable entry	2 x ½" NPT thread, depending on the type
Wire cross-sectional area of the connecting wires, including earth terminal (PE)	14...20 AWG
Direction of rotation	Facing the shaft end (mounting surface):
<ul style="list-style-type: none"> • SQM40 • SQM41 • Non-reversible 	Counterclockwise (CCW) Clockwise (CW)
Torque	35 in-lb / 75 in-lb / 133 in-lb depending on type ¹⁾
	1) Specifications apply to ambient temperatures of 15 °F and a mains voltage of AC 120 V and a mains frequency of 60 Hz. At a mains frequency of 50 Hz, the torque increases by approximately 20%.
Torque tolerance	-25%
	Valid at the tolerance limits of temperature and operating voltage
Holding torque	50% of the torque for types with 35 in-lb, 75 in-lb, and 133 in-lb torque
Running time	12.5 s / 25 s / 54 s depending on type ¹⁾
	1) Specifications apply to ambient temperatures of 15 °F and a mains voltage of AC 120 V and a mains frequency of 60 Hz. At a mains frequency of 50 Hz, the torque increases by approximately 20%.
Running time tolerance	±10%
Pause time at change in direction of rotation, zero-current state	>100 ms

General unit data	End and auxiliary switches	
	• Type	To DIN 41636
	• Switching voltage	AC 24...250 V
	• Switching capacity	See specifications in chapter <i>Connection diagrams</i>
	Number of end switches	2
	Number of auxiliary switches	Max. 4, depending on type
	Drive shaft	Supplied as standard, non-exchangeable
	Weight	Approx. 4 lbs
	Temperature of the mounting surface	Max. 140 °F
	Rated surge voltage	Overvoltage category III in accordance with DIN EN 60730-1 chapter 20 Pollution degree 2
	Backlash between the actuator motor and actuator shaft	
	- From the factory	<1°
	- after 250,000 cycles	<1.2°
	Lifetime	250,000 start cycles (close ⇔ open ⇔ close) under load with the proper torque rating throughout the entire range of operation. 2,000,000 control cycles under load with 75% of the rated torque value and 10° range of operation.
Analog inputs		
Low voltage	General	
	Linearity	<5% of the control range
	Control range	0...90° or 0...135°, depending on type
	Voltage setpoint	DC 2...10 V
	- Umin	DC 2 V
	- Umax	DC 10 V
	Input impedance	≥5 kΩ
	Current setpoint	DC 4...20 mA
	- Imin	DC 4 mA
	- Imax	DC 20 mA
	Input impedance	≤500 Ω
	Impedance setpoint	0...135 Ω
	- RNominal	135 Ω ±5%

For use in North America	Cross-sectional area of the power supply lines	
	SQM4x.x1xxxx / SQM4x.x4xxxx / SQM4x.x5xxxx, (X2), (PE) SQM4x.x6xxxx / SQM4x.x7xxxx / SQM4x.x8xxxx, (X1)/(X2)/(X3), (PE) SQM4x.x1xxxx / SQM4x.x2xxxx SQM4x.x4xxxx / SQM4x.x5xxxx (X1)	Class 1, min. AWG 16 Suited for 220 °F Max. 2.5 mm ² or AWG 14 Class 2, min. AWG 22 Suited for 220 °F Max. 1 mm ² or AWG 18
	NEMA classification	NEMA4

Outdoor use



ATTENTION:
 Waterproof cable conduits and cable glands are required (e.g. type DWTT/7 or QCRV2/8)

Environmental conditions	Storage	DIN EN 60721-3-1:1997
	Climatic conditions	Class 1K3
	Mechanical conditions	Class 1M2
	Temperature range	-4...140 °F
	Humidity	<95% r.h.
	Transport	DIN EN 60721-3-2:1997
	Climatic conditions	Class 2K3
	Mechanical conditions	Class 2M2
	Temperature range	-4...140 °F
	Humidity	<95% r.h.
	Operation	DIN EN 60721-3-3:1995
	Climatic conditions	Class 3K5
Mechanical conditions	Class 3M4	
Temperature range	-4...140 °F 5...140 °F for 133 in-lb design	
Humidity	<95% r.h.	
Installation altitude	Max. 2,000 m above sea level	



NOTICE:
 Condensation and ingress of water are not permitted. If this is not observed, there is a risk of loss of safety functions and a risk of electric shock.

Conductive plastic potentiometer	Resistance	2*1000 Ω double potentiometer with separated resistance tracks
	Operating voltage	DC 10 V
	Permissible hysteresis	0.3% of 90° or of 135°, depending on type
	Total resistance tolerance	±20%
	Effective angular rotation	90° or 135°, depending on type
	Terminal strip	Triple-pole
	For cross-sectional areas of	0.5...1 mm ²
	Wiper current rating	Max. 100 μA
	Transfer resistance of wiper contact	Max. $R_{ü} \leq 100 \Omega$
	Linearity (referred to $R_{ges} = 1000 \Omega$)	±1%
	Smoothness (alpha = 10°) / microlinearity	<0.5%
	Lifetime	Approx. 2 million positioning cycles
	Temperature coefficient	0.4 Ω/K

<p>Conductive plastic potentiometer connection diagram</p>		<p>Potentiometer drawn in start position (as supplied).</p> <p>Terminal markings: a = high end of potentiometer b = potentiometer wiper c = low end of potentiometer</p>
--	--	---

Apply operating voltage only on terminals «a» and «c». Conductive plastic potentiometers can be destroyed if operating voltage is applied incorrectly between «a → b» or «b → c».

The polarity of the potentiometer end pickups «a → c» must be observed in order to achieve the correct signal direction to the potentiometer wiper «b».

If the potentiometer specified for 90° is operated outside of the effective range of angular rotation of 90°, no valid signal will be present at the wiper contact (interrupted circuit).

This can happen if the switch position of the switching cam I for high-fire is configured for over 90°. The 90° version is used for both directions of rotation, SQM40 (counterclockwise) and SQM41 (clockwise).

The 135° versions are intended for a particular direction of rotation.

Position indication, default setting and colors of the cam disks



NOTE:
 Ensure correct direction of rotation!

SQM40 (left, CCW)

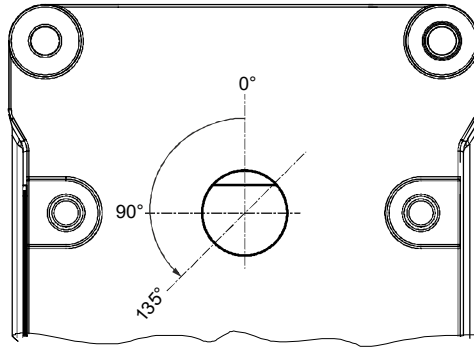

SQM41 (right, CW)

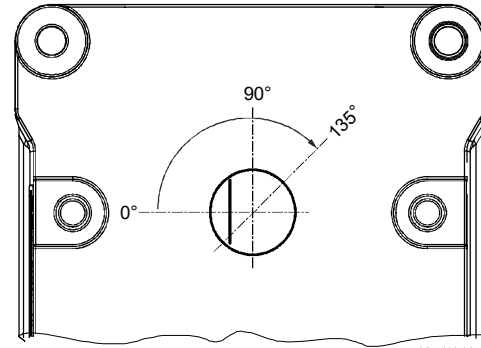

7817z13/0315

Position indication SQM40
 External position scale
 Marking in slot shape

Position indication SQM41
 Internal position scale
 Marking in arrow shape

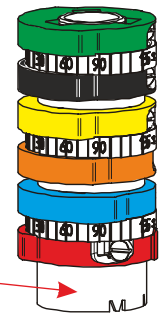
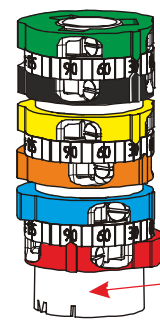

Pay attention to markings!

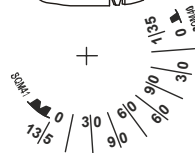
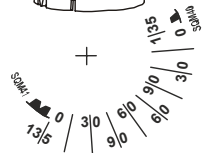

NOTE:
 The setting of the switch positions must be checked before startup.

Connection diagrams and connection terminals

SQM4x.x1xxxx

Electronic version with independent high-fire and low-fire feedback



NOTE:

For the sake of clarity, the plug-in contacts do not appear in sequential order in the circuit diagram. Consecutive numbers are printed on the unit, however, e.g. 1...7.

Cam diagram

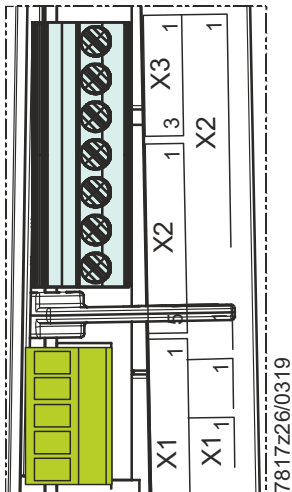
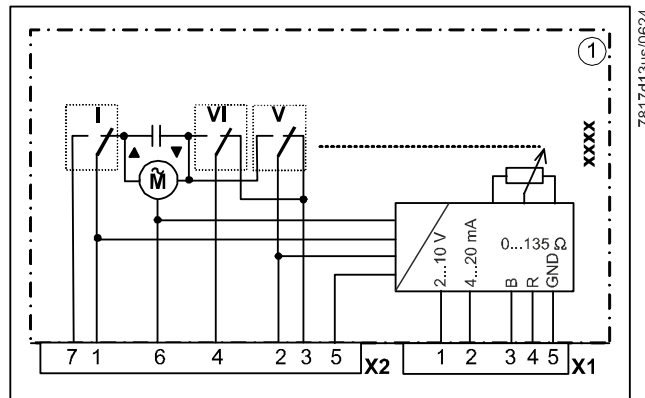

Mains voltage terminals			Dimensioning
X2-1	Open (I)	Input	AC 120 V / max. 1 A, $\cos\phi > 0.9$ *
X2-2	Move to low-fire (V)	Input	AC 120 V / max. 1 A, $\cos\phi > 0.9$ *
X2-3	Low-fire position reached (V)	Output	AC 120 V / max. 10 mA, $\cos\phi > 0.9$
X2-4	Close / ignition (VI)	Input	AC 120 V / max. 1 A, $\cos\phi > 0.9$
X2-5	Controller release	Input	AC 120 V / max. 60 mA / 30 mA
X2-6	Neutral	Input	AC 120 V / max. 60 mA / 30 mA
X2-7	'OPEN' position reached (I)	Output	AC 120 V / max. 10 mA, $\cos\phi > 0.9$
Mains voltage terminals			Dimensioning
X1-1	2...10 V	Input	max. DC 10 V to X1-5
X1-2	4...20 mA	Input	max. 20 mA to X1-5
X1-3	0...135 Ω B	Input	---
X1-4	0...135 Ω R	Input	---
X1-5	0...135 Ω W (GND)	Input	---

* Only the control lines to the burner controls or to the control unit may be connected at the marked terminals. It is not permitted to connect additional external loads, such as signal lamps.



NOTE:
 The setting of the switching positions must be checked before commissioning.

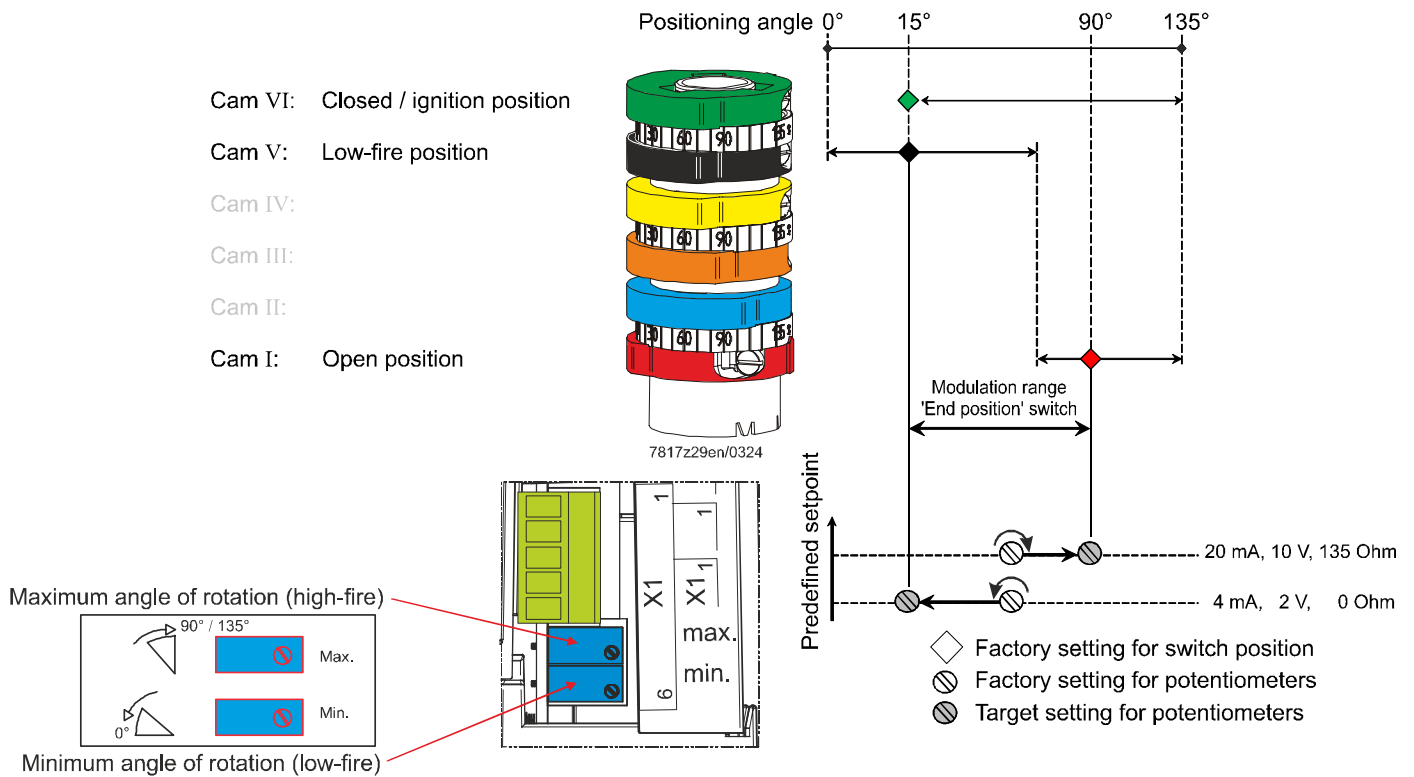

Modulation always takes place between high-fire (cam I) and low-fire (cam V). It is also possible to limit the modulation range via 2 potentiometers and thus adjust the characteristic curve for the dependency between the predefined setpoint and the angle of rotation.



NOTE:
 Direction of rotation of the potentiometer setting.
 The direction of rotation of the potentiometer setting must be observed during commissioning.

**Setting range /
modulation range**

Adjust the range of the analog signal to match the switch positions (minimum and maximum position):

Set cam (I) to the required high-fire position

Set cam (V) to the required low-fire position

Apply predefined setpoint for the high-fire position at the analog input (depending on the type and application, the predefined setpoint can be applied in terms of current (4...20 mA), voltage (2...10 V) or resistance (0...135 Ohm)

Set the potentiometer for the maximum angle of rotation (default setting is the center position):

If the SQM40/SQM41 has not yet reached the maximum angle of rotation, the potentiometer must be turned clockwise until the predefined setpoint, the current angle position of the SQM40/SQM41, and the shutdown by the cam switch all match
OR

If the SQM40/SQM41 has already reached the maximum angle of rotation, the potentiometer must be turned counterclockwise until the predefined setpoint, the current angle position of the SQM40/SQM41, and the shutdown by the cam switch all match

Apply predefined setpoint for the low-fire position at the analog input (depending on the type and application, the predefined setpoint is 4 mA, 2 V, or 0 Ohm)

Set the potentiometers for the minimum angle of rotation:

If the SQM40/SQM41 has not yet reached the minimum angle of rotation, the potentiometer must be turned counterclockwise until the predefined setpoint, the current angle position of the SQM40/SQM41, and the shutdown by the cam switch all match
OR

If the SQM40/SQM41 has already reached the minimum angle of rotation, the potentiometer must be turned clockwise until the setpoint specification, the current angle position of the SQM40/SQM41, and the shutdown by the cam switch all match

The two potentiometers are electrically coupled with each other. This means that a change to one potentiometer has a retroactive effect on the setting value of the other potentiometer. It is therefore necessary to check the end positions for the minimum and maximum predefined setpoint and repeat steps 4 to 7 if necessary.

Connection diagrams and connection terminals

SQM4x.x4xxxx

Electronic version



NOTE:

For the sake of clarity, the plug-in contacts do not appear in sequential order in the circuit diagram. Consecutive numbers are printed on the unit, however, e.g. 1...7.

Cam diagram

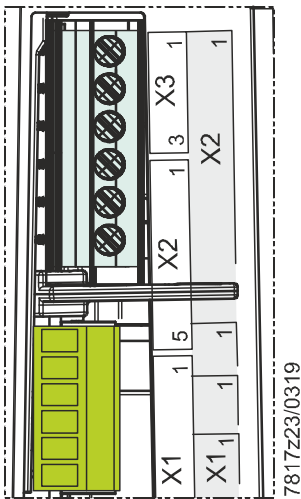
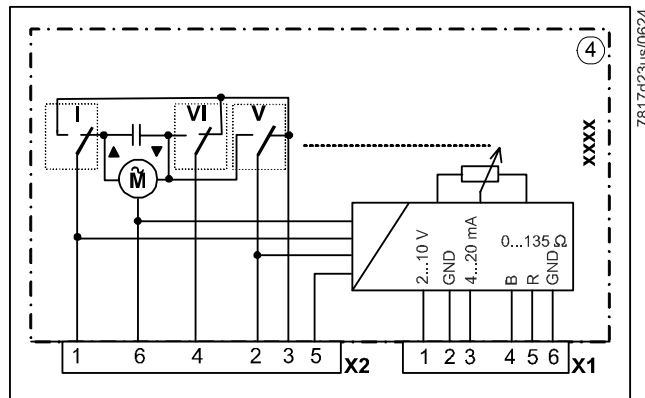

Mains voltage terminals			Dimensioning
X2-1	Opening (I)	Input	AC 120 V / max. 1 A, $\cos\phi > 0.9$ *
X2-2	Move to low-fire (V)	Input	AC 120 V / max. 1 A, $\cos\phi > 0.9$ *
X2-3	Position reached	Output	AC 120 V / max. 10 mA, $\cos\phi > 0.9$
X2-4	Closing/ignition (VI)	Input	AC 120 V / max. 1 A, $\cos\phi > 0.9$
X2-5	Controller release	Input	AC 120 V / max. 60 mA / 30 mA
X2-6	Neutral	Input	AC 120 V / max. 60 mA / 30 mA
Low-voltage terminals			Dimensioning
X1-1	2...10 V	Input	max. DC 10 V to X1-2
X1-2	GND	Input	---
X1-3	4...20 mA	Input	Max. 20 mA to X1-2
X1-4	0...135 Ω B	Input	---
X1-5	0...135 Ω R	Input	---
X1-6	0...135 Ω W (GND)	Input	---

* Only the control lines to the burner controls or to the control unit may be connected at the marked terminals. It is not permitted to connect additional external loads, such as signal lamps.



NOTE:
 The setting of the switching positions must be checked before commissioning.

- Cam VI: Closed / ignition position
- Cam V: Low-fire position
- Cam IV:
- Cam III:
- Cam II:
- Cam I: Open position

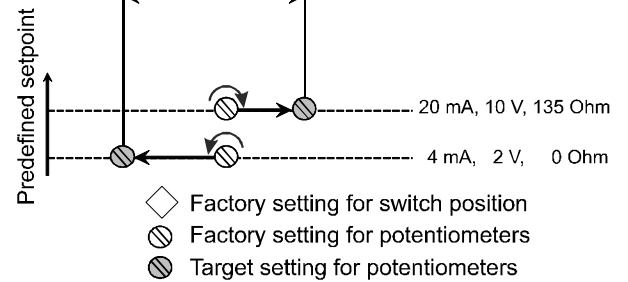
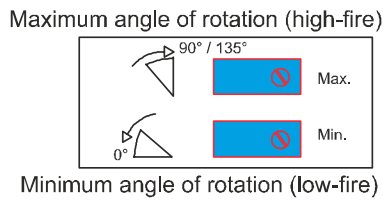
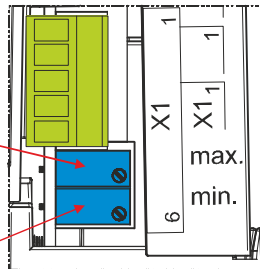
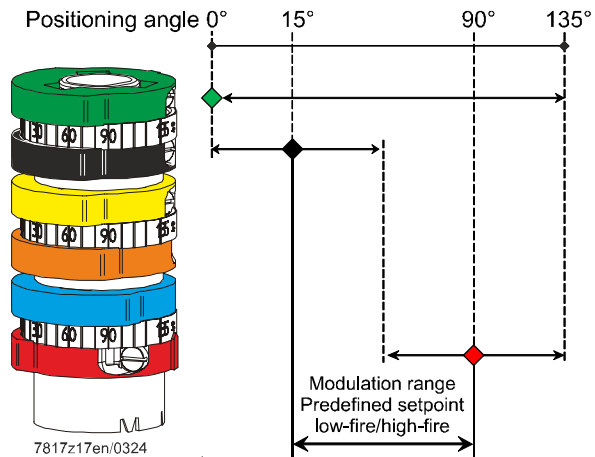

Range adjustment / modulation range

Adjust the range of the analog signal to match the switch positions (minimum and maximum position):

Set cam (I) to the required high-fire position

Set cam (V) to the required low-fire position

Apply predefined setpoint for the high-fire position at the analog input (depending on the type and application, the predefined setpoint can be applied in terms of current (4...20 mA), voltage (2...10 V) or resistance (0...135 Ohm)

Set the potentiometer for the maximum angle of rotation (default setting is the center position):

If the SQM40/SQM41 has not yet reached the maximum angle of rotation, the potentiometer must be turned clockwise until the predefined setpoint, the current angle position of the SQM40/SQM41, and the shutdown by the cam switch all match
OR

If the SQM40/SQM41 has already reached the maximum angle of rotation, the potentiometer must be turned counterclockwise until the predefined setpoint, the current angle position of the SQM40/SQM41, and the shutdown by the cam switch all match

Apply predefined setpoint for the low-fire position at the analog input (depending on the type and application, the predefined setpoint is 4 mA, 2 V, or 0 Ohm)

Set the potentiometers for the minimum angle of rotation:

If the SQM40/SQM41 has not yet reached the minimum angle of rotation, the potentiometer must be turned counterclockwise until the predefined setpoint, the current angle position of the SQM40/SQM41, and the shutdown by the cam switch all match
OR

If the SQM40/SQM41 has already reached the minimum angle of rotation, the potentiometer must be turned clockwise until the setpoint specification, the current angle position of the SQM40/SQM41, and the shutdown by the cam switch all match

The two potentiometers are electrically coupled with each other. This means that a change to one potentiometer has a retroactive effect on the setting value of the other potentiometer. It is therefore necessary to check the end positions for the minimum and maximum predefined setpoint and repeat steps 4 to 7 if necessary.