

Open / Closed



SKP15

Open / Closed  
with constant pressure  
governor



SKP25

Open / Closed  
with differential pressure  
governor



SKP55

Open / Closed  
with ratio pressure governor



SKP75

## Actuators for gas valves

## SKPx5...

- OPEN/CLOSED safety shut-off function according to EN 161 and control function according to EN 88 in connection with the VGx/VRx valves from Siemens AG
- Damped opening (rapid closing)
- Very low power consumption
- Suitable for use with gases of gas families I...III
- Optionally with / without end switch (factory-set)
- Plug-in connection facility
- Electrical indication of operation
- Valve stroke indication
- Supplementary Data Sheets on valves (refer to «Use»)
- Models for USA on request

The SKPx5 and this Data Sheet are intended for use by OEMs which integrate the actuators in their products.

## Use

Modular concept

The SKPx5 actuator is designed for use with the following types of valves:

Type of valve	Medium	Data Sheet
VGG	Natural gas	N7636
VGf	Gases of gas families I...III	
VGD2	Natural gas	N7631
VGD4	Gases of gas families I...III	
VRD	Natural gas Biogas (with SKP15, other actuators on request) Gases of gas families I...III	N7631
VRF	Biogas (with SKP15, other actuators on request)	N7633

Actuators SKPx5 in general

The combination of an SKPx5 actuator and a valve performs the following functions:

- Safety shutoff valve (SKP15)
- Safety shutoff valve with gas pressure governor (SKP25, SKP55, SKP75)

Together with a valve, the electrohydraulically operated SKPx5 actuators are primarily designed for use in gas-fired combustion plants. The SKPx5 actuators open slowly and close quickly. The SKPx5 actuator can be supplied with end switches (for indicating the fully closed position). For information about valve sizing, refer to the «Valve sizing chart» in the Data Sheet of the relevant valve.

If the SKPx5 actuators are used with gases other than those in gas families I...III, Siemens AG assumes no responsibility for the durability and lifetime of the SKPx5 actuators.

All SKPx5 actuators can be combined with any of these valves.

### SKP15

Together with a VGx/VRx valve, the electrohydraulically operated SKP15 works exclusively as a safety shutoff valve (OPEN/CLOSED) and is primarily used in gas-fired combustion plants. The SKP15s open slowly and close quickly. A valve stroke display on the SKP15 can only be delivered with end switches.

### SKP25

The SKP25 operates with a gas pressure governor and controls the gas pressure according to the setpoint preselected with the setpoint spring or air pressure signal.

Its field of use is primarily forced draft gas burners

- with mechanical air / fuel ratio control (SKP25.0)
- with electronic air / fuel ratio control (SKP25.0)
- with 2-stage setpoint changeover (SKP25.2)
- with proportionate governor (SKP25.3)
- with high-pressure control up to 200 kPa (SKP25.4)
- with zero pressure governor (SKP25.6)
- with constant pressure control, but with electric pressure setpoint adjustment (SKP25.0 with AGA30.7 and SAS)

**SKP25.0 with AGA30.7 and SAS**

The SKP25.0 with AGA30.7 and SAS solution enables motorized pressure setpoint adjustment

- for motorized setting or correction of the setpoint
- for atmospheric and comparable burner operating conditions, typical output modulation multistage or shifting < 1 : 5
- not for gas-air ratio combined systems (e.g. class C in accordance with EN 12067-2)
- SKP25.0 (with AGA30.7 and SAS) must not be used in applications that require mechanical operating conditions higher than class 3M1 (EN 60721-3-3:1995 + A2: 1997). Vibrations are not permitted. Corrective measures must be implemented on the plant in individual cases.

**SKP55**

The SKP55 operates with a differential pressure governor and controls a differential gas pressure according to a differential air pressure. The ratio of the differential pressures is 1:1 and remains constant across the entire air range.

Its field of use is predominantly

- combustion plant with combined heat recovery systems
- plant where pressure conditions in the burner and combustion chamber do not change in proportion to load changes
- burners with adjustable air / fuel mixing devices in the burner head
- plant with negative pressure levels on the gas or air side

**SKP75**

The SKP75 operates as a ratio pressure governor and provides control of the gas pressure depending on the pressure of the combustion air, ensuring that the adjustable gas / air ratio remains constant across the entire load range. Its field of use is primarily modulating forced draft gas burners.

**Warning notes**

---



**For additional safety notes, refer inside of Data Sheet!**

**To prevent injury to persons, damage to property or the environment, the following warning notes must be observed!**

- Do not open, interfere with or modify the actuators!
- Any opening of the actuator, replacement of parts or modifications to the original product is the user's responsibility and carried out at his own risk
- All activities (mounting, installation and service work, etc.) must be performed by qualified staff
- When used in connection with gas, the actuators constitute part of the safety equipment
- Not suitable gases or gas components causes loss of the safety shutoff function
- Check to ensure that the impulse pipes are correctly fitted and tight (SKP25, SKP55, SKP75)
- Fall or shock can adversely affect the safety functions. Such actuators must not be put into operation, even if they do not exhibit any damage
- Each time work has been carried out (mounting, installation, service work, etc.), check to ensure that wiring is in an orderly state and make the safety checks as described in «Commissioning notes»
- If mains voltage is fed to the end switch (CPI), protective earth must be connected to the actuator via the same plug (AGA65)
- Use of connectors conforming to EN 175301-803-A is mandatory
- The connectors used must feature cable strain relief
- Solar radiation or formation of ice are not permitted!

**SKP25.2**

When using SKP25.2, relevant interference suppression measures (EMC) must be implemented on the plant side.

The magnet can reach high temperatures if activated for longer periods of time.

The SKPx5.xx1xx are supplied with the end switch factory-set.

Design of the gas train

If the available gas pressure exceeds the maximum permissible operating pressure of the valve (VGx/VRx) or the SKPx5 respectively (refer to the data sheet for the relevant valve), it must be lowered by an upstream pressurestat. The gas pressure switch for lack of gas must always be fitted upstream of the valve (VGx/VRx) when used in connection with the SKPx5.



**Note!**  
When setting the overpressure limit, ensure it is lower than the load limit for the plant.

**SKP25, SKP55, SKP75**

The impulse pipes must be installed such that the differential pressure can be acquired with no disturbance (unfavorable flow conditions). Pressure test points must not protrude and be flush with the inside diameter of the pipe or duct wall. The impulse lines to the governor should be as short as possible, enabling the governor to respond quickly should sudden load changes occur. The inside diameter of the impulse pipes must be a minimum of 6 mm. In connection with the SKP25, the 1/4" nozzles on the outlet side of the VGx/VRx valves can be used as pressure test points (prerequisite: gas control pressure setpoint >1 kPa).



**CAUTION!**  
**Risk of gas leak!**  
The pressure test point must be closed again once the pressure has been measured. It is essential to check the seal is tight.  
Failure to observe this information poses a risk of personal injury, property damage, and environmental harm.



**PLEASE NOTE!**  
**Risk of gas leak and loss of control function!**  
The maximum permissible inlet pressure of the SKPx5 with VGx/VRx combination is determined by the component installed in the application with the lowest maximum permissible operating pressure in each case. Failure to observe this information poses a risk of personal injury, property damage, and environmental harm.

**SKP75**

- Installation of impulse pipes:  
In the case of unsafe combustion chamber pressure pipes (e.g. resulting from potential leaks). The setting must also be checked during operation without having the combustion chamber pipe connected, especially with respect to maximum burner capacity. The impulse pipes must be fitted such that the differential pressure can be acquired with no disturbance. With gas / air ratios  $>3$ , the impulse pipes for the combustion air and the combustion chamber pressure must have an inside diameter of at least 8 mm. The impulse pipe for the combustion chamber pressure must be fitted such that the gases will cool down in the vicinity of the impulse pipe and condensing gases cannot enter the governor but will return to the combustion chamber.



**Warning!**

**If there is a risk of the impulse pipes being exposed to heat, all impulse pipes must be made from suitable metal material**

Recommendations:

- The gas pressure should be acquired at a distance of 5 times the nominal pipe size downstream from the valve
  - that the lateral pressure test points on the valve should not be used for picking up the pressure.
- Considering the combustion chamber pressure:  
If the resistance value of the combustion chamber / heat exchanger / stack system is constant, the combustion chamber pressure changes in proportion to the gas and combustion air pressure as the burner's output changes. In that case, the combustion chamber pressure need not be fed to the SKP75 as a disturbance variable. However, if the combustion chamber pressure does not change to the same extent as the gas and air pressure – as this is the case in plants with flue gas fan or modulating flue gas damper – the combustion chamber pressure must be fed to the SKP75 as a disturbance variable, enabling the governor to counteract.
  - If the SKPx5 are operated until the end of their lifecycle, the decreasing drive power can result in a lower gas quantity or gas pressure on the outlet of the gas fitting. If the use requires a minimum pressure behind the gas fitting, the minimum pressure must be monitored

## Mounting notes

---

- Ensure that the relevant national safety regulations are complied with
- The quadratic arrangement of the fixing holes allows the actuator to be fitted in 4 different positions on the VGx/VRx valve, each step being 90° (depending on the type of VGx/VRx valve)
- The actuator can be mounted or replaced while the system is under pressure; sealing material is not required
- SKP25 / SKP55 / SKP75:  
SKPx5 with pressure control function have a vent opening on the pressure governor. Measures must be taken in the application to prevent the vent opening from being blocked



### Warning!

**Condensation, formation of ice and ingress of water are not permitted. If this is not observed, there is a risk of loss of safety functions and a risk of electric shock.**

### Sealing / tightness

- Check the tightness when all components are connected

### SKPx5 general

- Electrical commissioning may only be carried out with the SKPx5 fitted to the valve; otherwise the SKPx5 may be damaged
- Power is supplied and connection of the end switch is made directly via a connecting cable (conforming to EN 175301-803-A))
- The end switch is factory-set
- The pump tappet must not be pulled. This could damage pump elements and cause the brass part to come loose.

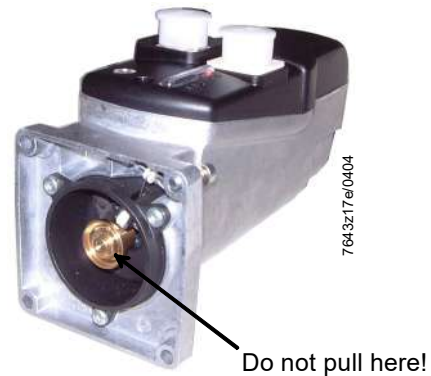

## Installation and commissioning notes

Functional principle of the 1-stage **SKP15** with safety shut-off function

When power is applied, the pump will be activated and the control valve closed. Oil is now pumped from the chamber below the piston to the stroke chamber above the piston. The oil pressure causes the piston to move downward, thereby opening the valve – against the pressure of the closing spring. The pump remains energized until the closing command is given. When power is removed, or in the event of a power failure, the pump will be deactivated and the control valve opened so that the closing spring pushes the piston back. The return flow system is sized such that the counter-stroke required for reaching the fully closed position is completed within about 0.6 seconds.

SKP15 complete with valve

(Schematic drawing)

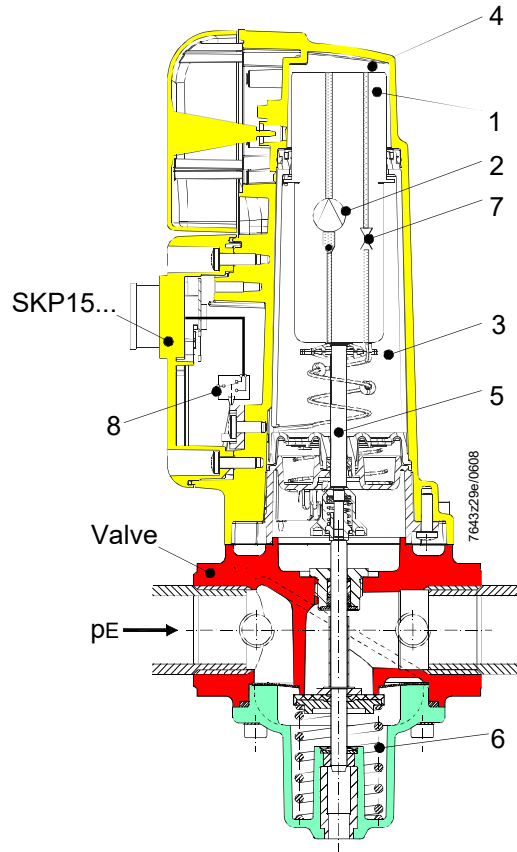

### Legend

- 1...4 Electrohydraulic actuator
- 5 Stem
- 6 Valve's closing spring
- 7 Control valve
- 8 End switch, valve closed (optional)

**SKP25, SKP55 and SKP75**

The functioning principle (safety shutoff feature) is identical to that of the SKP15, but with the help of their pneumatic governor, the SKP25, SKP55 and SKP75 also control a bypass valve in the hydraulic circuit and thus the valve's opening position.



**Please note!**

**Risk of gas leak and loss of control function!**

The operating pressure of valves with a maximum permissible inlet pressure of >120 kPa must be limited to 120 kPa in combination with the following SKPx5s:

- SKP25.0
- SKP25.2
- SKP25.3
- SKP25.6
- SKP55
- SKP75

The SKP25.4 extends the operating pressure range to 230 kPa.



Installation and commissioning notes (cont'd)

SKP25 / SKP55 /  
SKP75

- Key  
 ① Gas pressure test point  
 ② Combustion chamber pressure

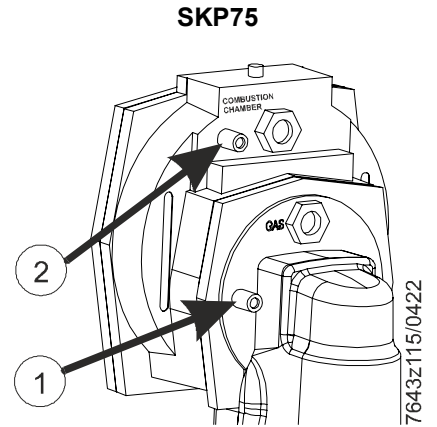
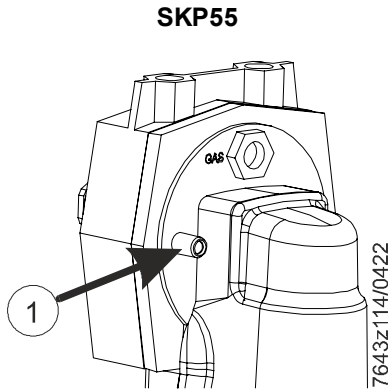
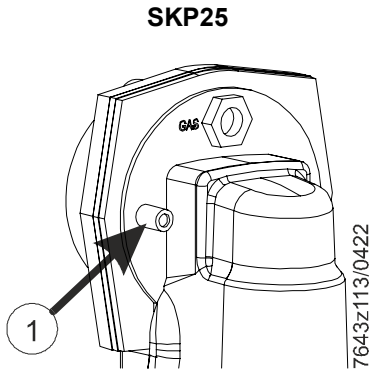

Step 1

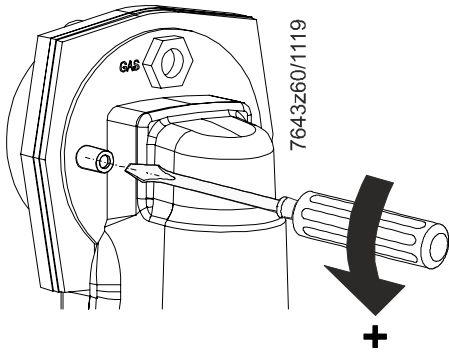

Step 2

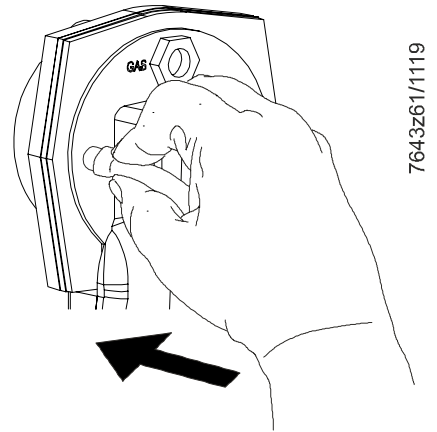

Step 3

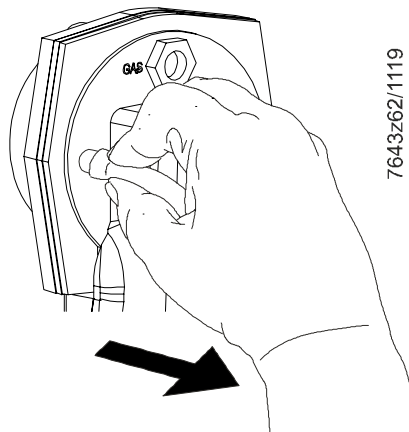

Step 4

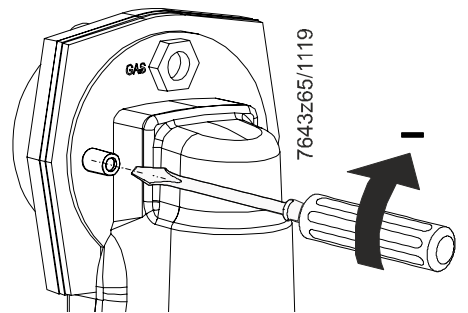

**Please note!**

**Risk of gas leak!**

The pressure test point must be closed again once the pressure has been measured. It is essential to check the seal is tight. Failure to observe this information poses a risk of personal injury, property damage, and environmental harm.

SKP25 complete with valve

(Schematic drawing)

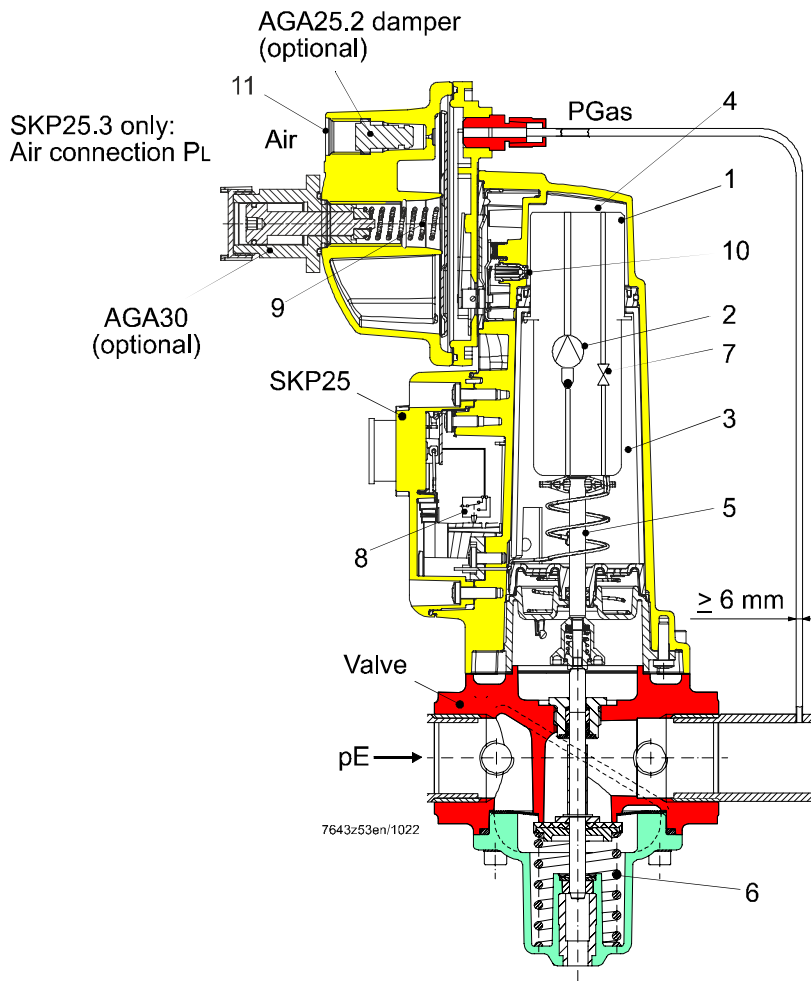

Legend

- 1...4 Electrohydraulic actuator
- 5 Stem
- 6 Valve's closing spring
- 7 Control valve
- 8 End switch, valve closed (optional)
- 9 Spring (setpoint adjustment)
- 10 Bypass valve
- 11 Vent opening / correction variable for combustion chamber pressure

SKP25

Setpoint adjustment «PGas» is made manually by turning the setting screw, which acts on the setpoint spring (for setpoint springs, refer to «Accessories»).

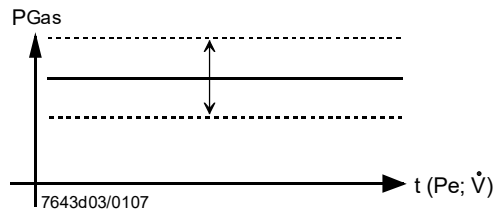

Legend

- Pe Inlet pressure
- $\dot{V}$  Volumetric flow
- PGas 0...2.2 kPa (with built-in AGA29 standard spring), presetting 1.5 kPa

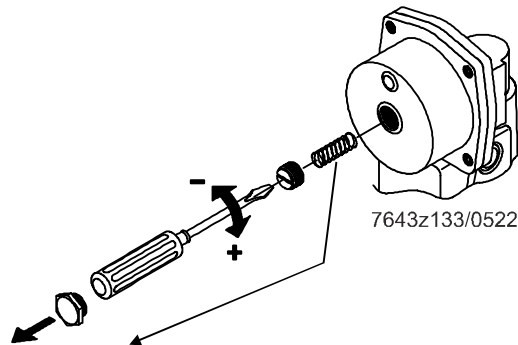

Installation and commissioning notes (cont'd)

SKP25

Color	Spring (Type)	SKP25.0 Setpoint range (kPa)	SKP25.4 High-pressure version Setpoint range (kPa)	SKP25.3 Offset range (kPa)	SKP25.6 Offset range (kPa)
Unpainted	AGA29	0...2.2	---	---	---
Yellow	AGA22	1.5...12	7...70	---	---
Red	AGA23	10...25	15...150	---	---
Transparent	AGA28	---	---	±0.15	---
Transparent	---	---	---	---	0...-0.9

SKP25.0

Default pressure setting

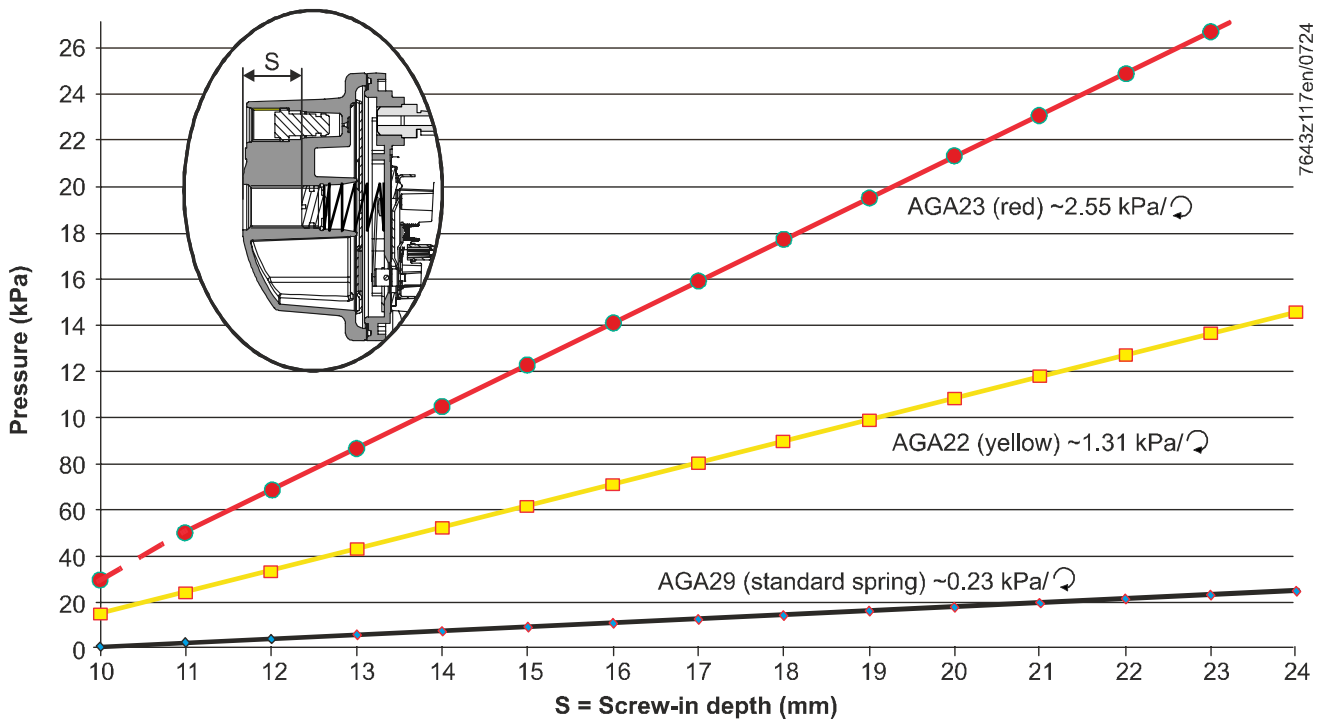

**SKP25 with AGA30.7 and SAS**

The SKP25.0 (with AGA30.7 and SAS) operates like the SKP25 constant pressure governor, but features electromotoric adjustment of the setpoint spring.

It is used primarily in

- atmospheric or comparable burners in modulating or multistage operation
- individual burners or groups of burners on industrial furnaces (gas pressure correction and disturbance variable compensation)
- not approved for gas-air ratio combined solutions (e.g. class C in accordance with EN 12067-2)

**SKP25.0 complete with valve**

(simplified sectional view)

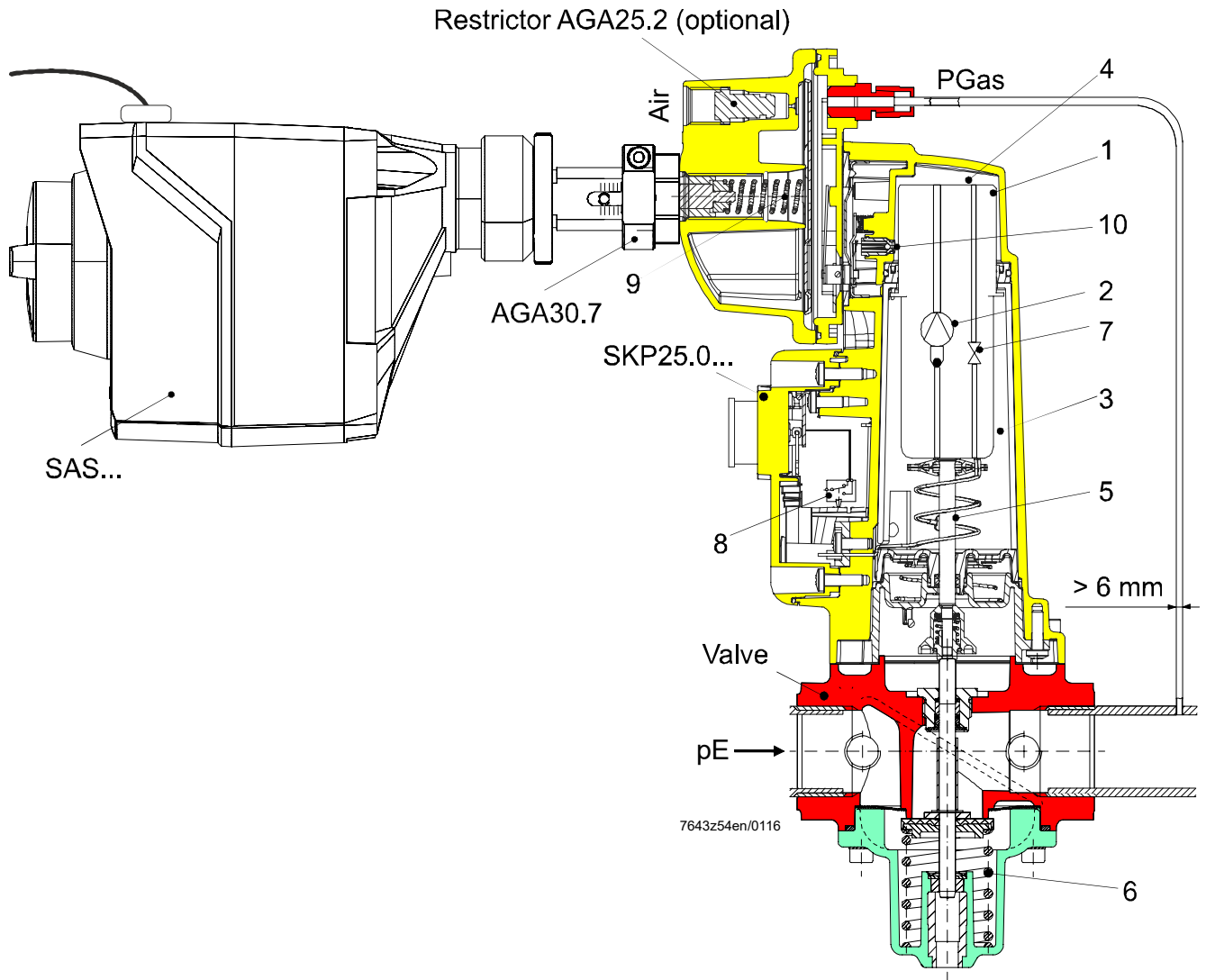

- Key
- 1...4 Electrohydraulic actuator
  - 5 Stem
  - 6 Closing spring of valve
  - 7 Control valve
  - 8 End switch, valve closed (optional)
  - 9 Position indication
  - 10 Bypass valve

**SKP25 with AGA30.7  
and SAS**

Functioning principle of the gas pressure governor with SAS motorized setpoint adjuster:

On the gas outlet side, the gas pressure governor maintains the pressure at the required setpoint. An electric signal on the SAS changes the specified setpoint (PR) proportionally. If the SAS motor stops, the outlet pressure remains constant.

Mounting the SAS onto  
the SKP25.0 with  
AGA30.7

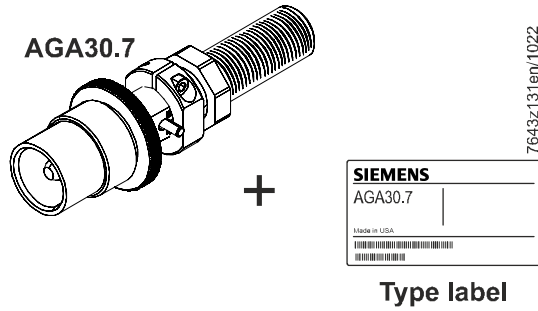

Pressure range in						
kPa	0.1...1.8	0.5...3.5	0.2...5.5	1.5...12	5...22.5	5...32
mbar	1...18	5...35	2...55	15...120	50...225	50...320
Color	Black	Black	Copper	Yellow	Red	Unpainted *)
Position number	①	①	②	③	④	⑤
Type (ASN)	Standard spring in SKP25.0 (AGA29)	AGA21	AGA26	AGA22	AGA23	7421500490 *) On request

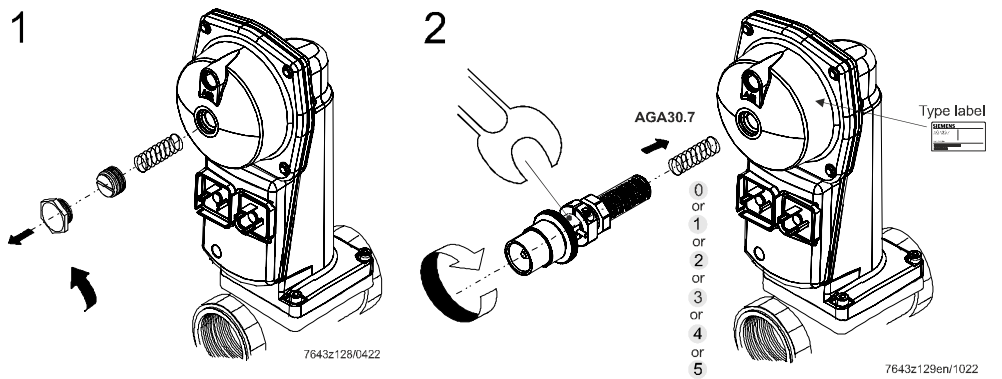

SKP25.0 with AGA30.7 and SAS

3

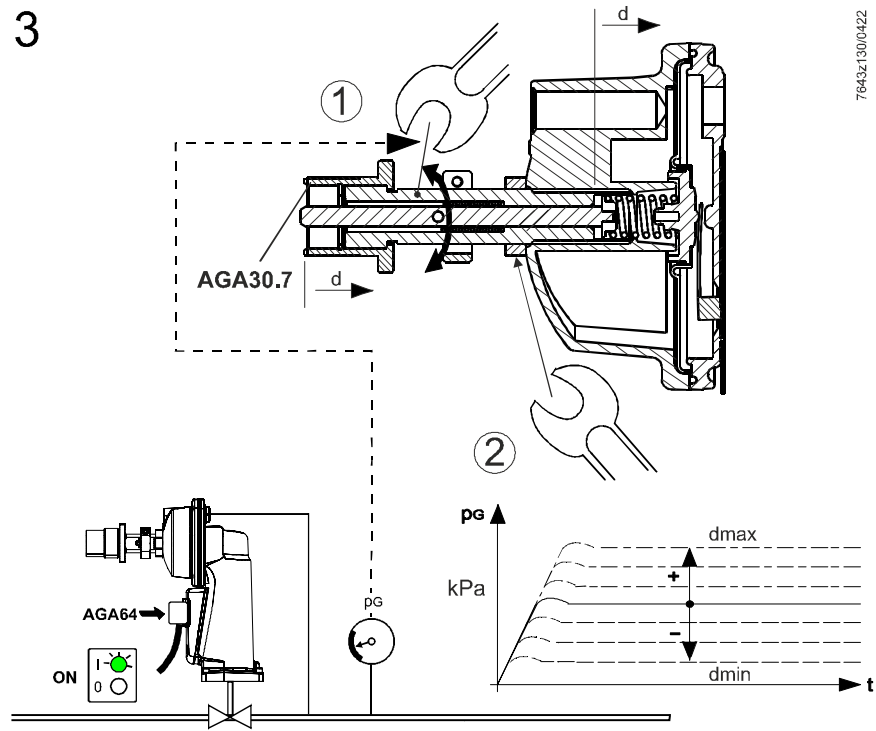

7643z130/0422

Key

- ① Pressure offset pG setting, without SAS
- ② After reaching the desired pG pressure, tighten the locknut with 30 Nm

	Pressure offset (kPa)					
Spring	①	②	③	④	⑤	⑥
Pmin	0.1	0.5	0.2	1.5	5	5
Pmax	0.7	1.5	0.5	5.5	10.5	12.5
Pressure range	0.6	1	0.3	4	5.5	7.5

SKP25.0 with AGA30.7 and SAS

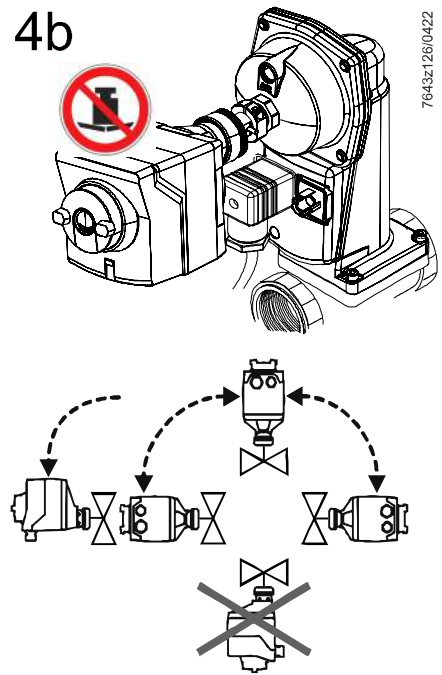
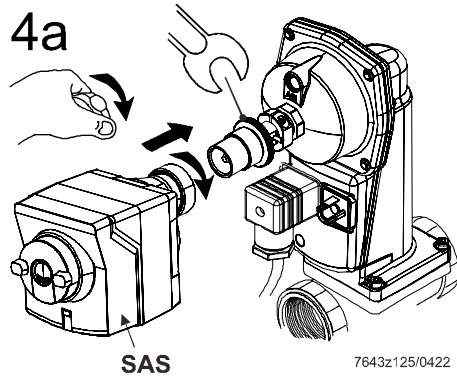

Pressure offset pG setting on SAS

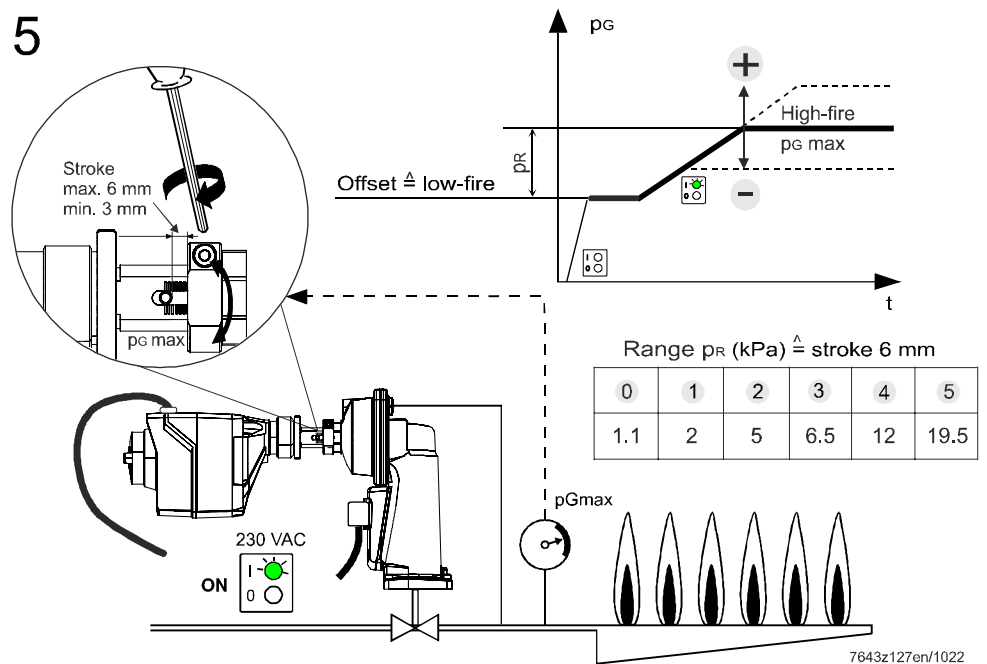

SAS

Different SAS motors can be used depending on the required function (e.g. electric control signal), see Data Sheet N4581.

**SKP25.2**

The SKP25.2 features 2-stage setpoint changeover for 2-stage gas burners.

Assembly of **SKP25.2** complete with valve

(Schematic drawing)

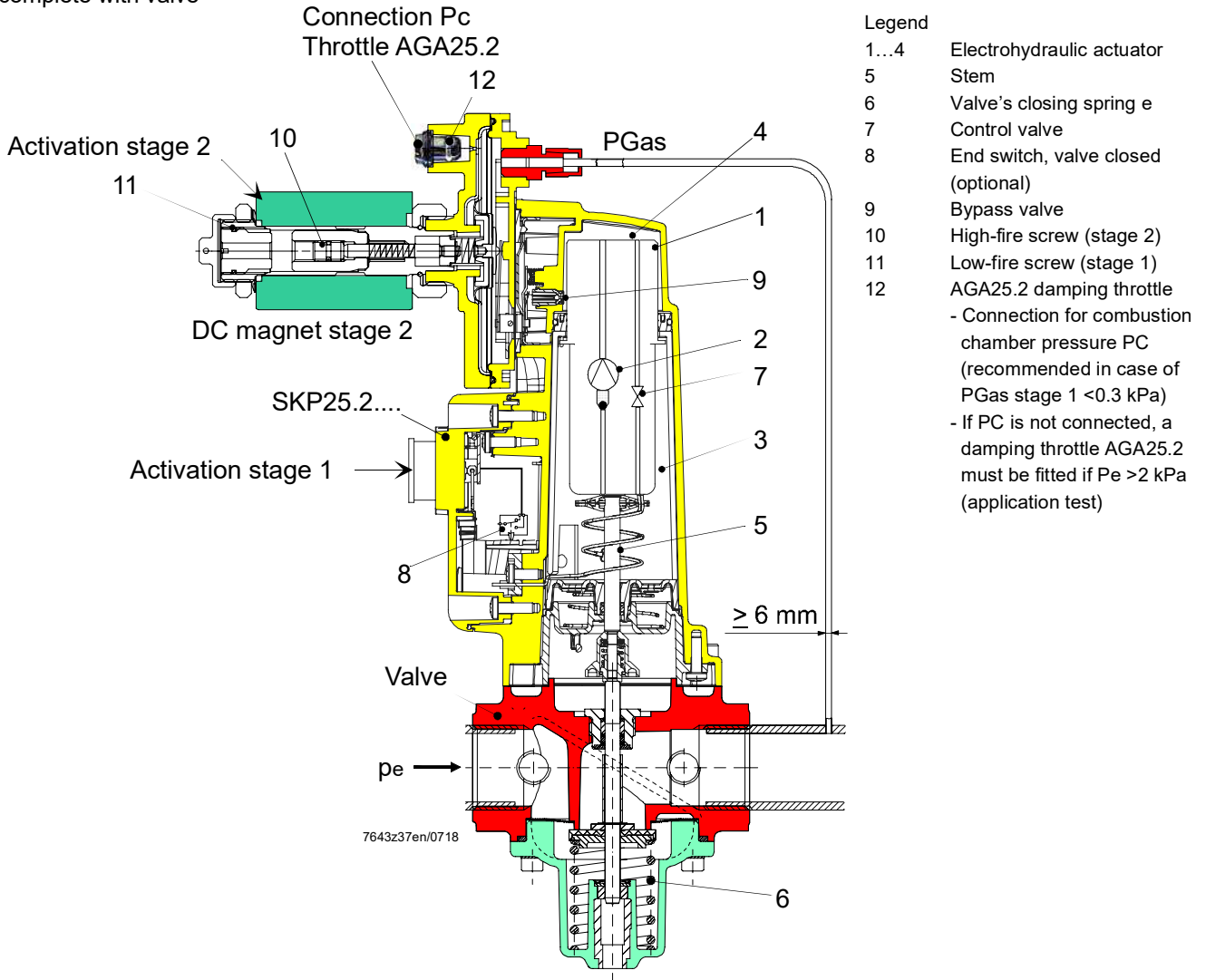

Setpoint adjustment «PGas» is made manually by turning the setting screws (10 and 11), which act on the setpoint spring. The high-fire pressure setting is only possible with stage 2 activated.

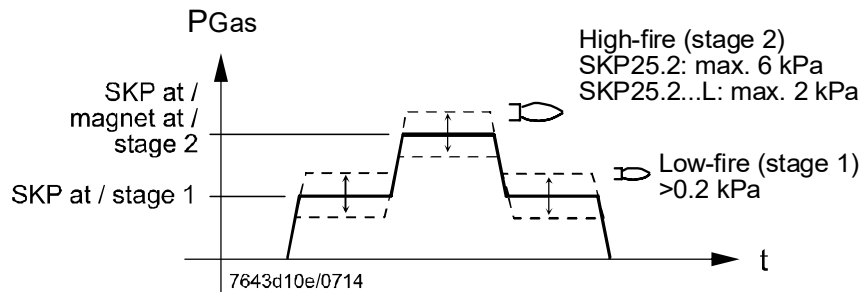



Setting the low-fire/high-fire on the SKP25.2

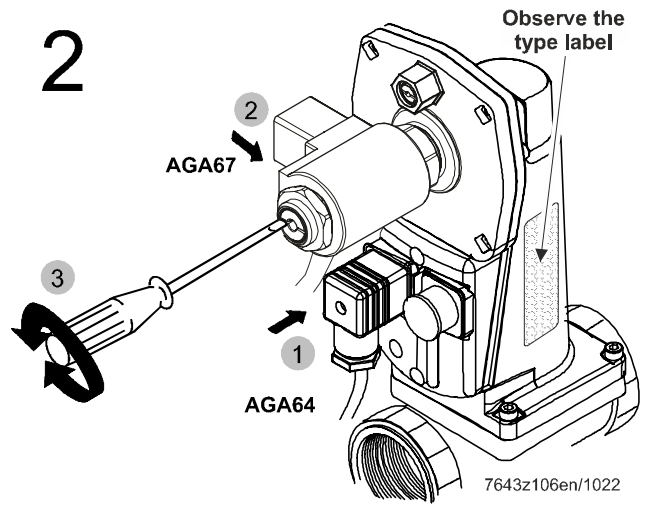
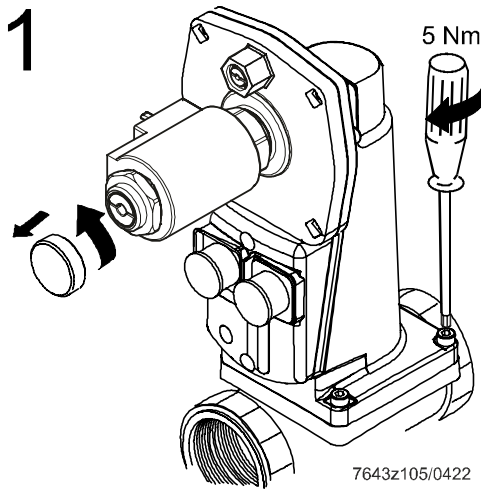

Setting low-fire

2a

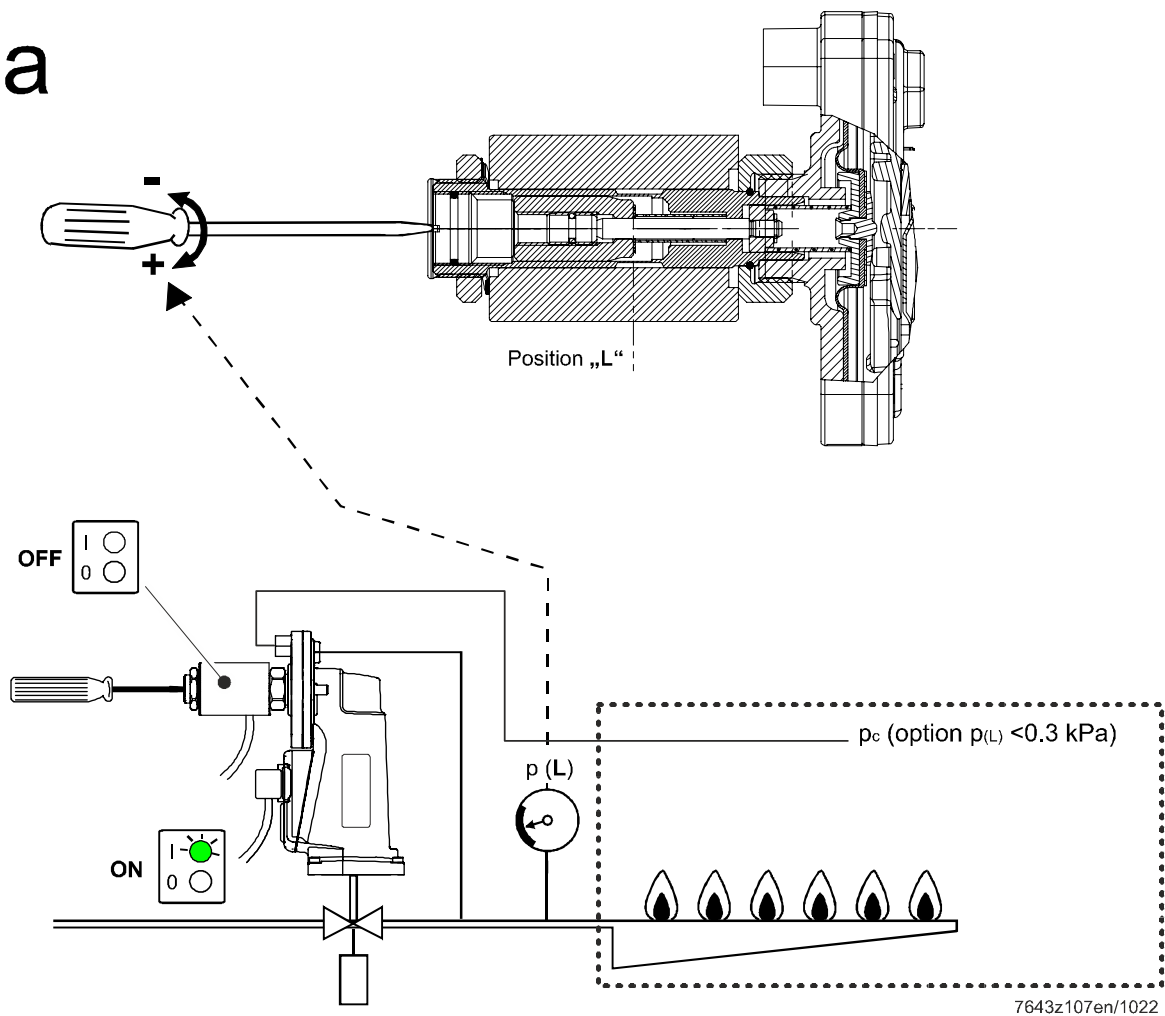

Setting the low-  
fire/high-fire on the  
SKP25.2 (continued)

3

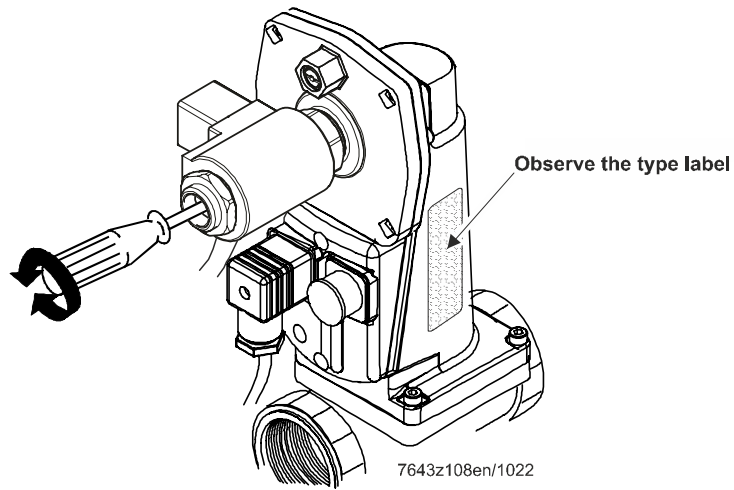

Setting the high-fire

3a

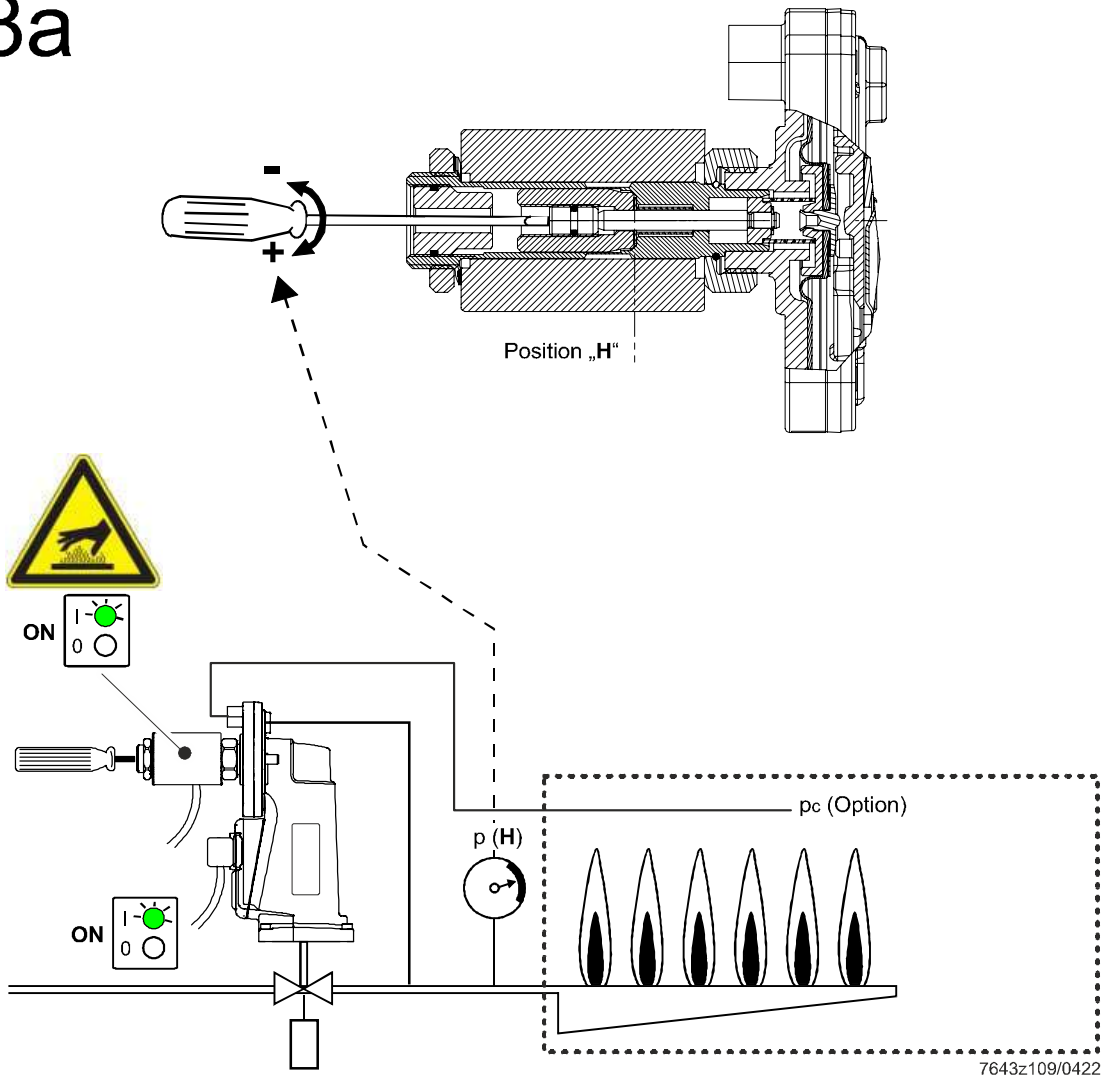

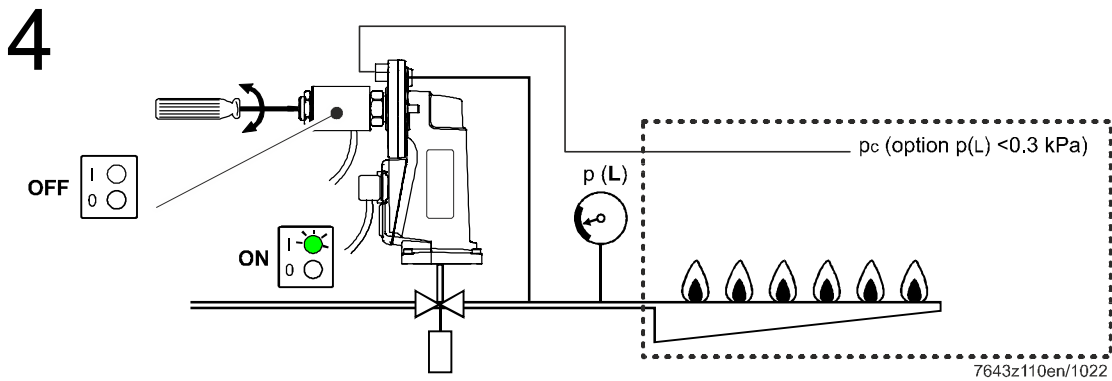

Setting the low-fire/high-fire on the SKP25.2 (continued)

Second low-fire setting (readjustment)

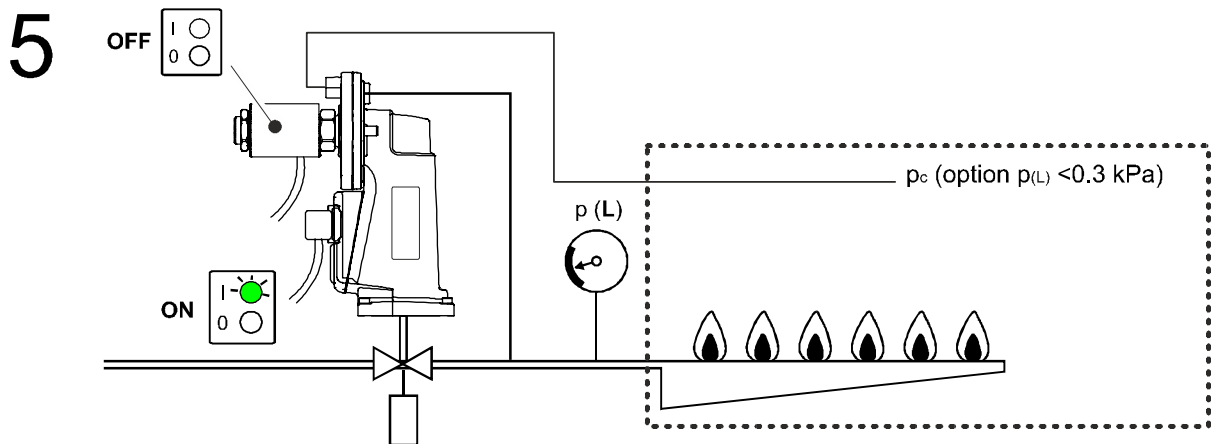

Operation



Default settings (kPa)		
	 (L)	 (H)
SKP25.2	1.2	5.5
SKP25.2xxExL	0.25	1.5

Setting the low-fire/high-fire on the SKP25.2 (continued)

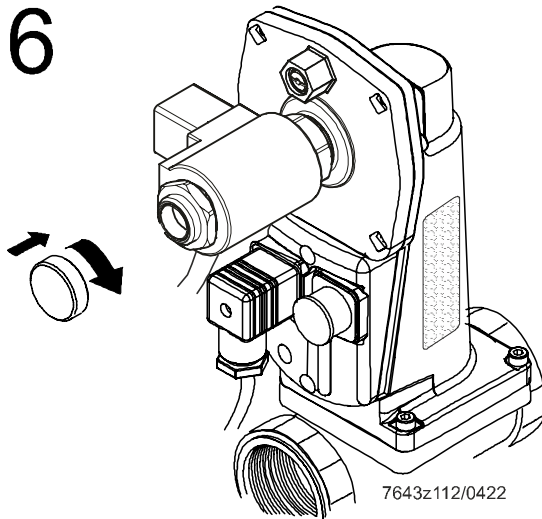

**SKP25.3**

The SKP25.3 operates based on the constant pressure governor principle  $PL : PG = 1:1$ . By connecting the fan pressure (PL) to the air connection, the gas pressure (PGas) follows at a fixed 1:1 ratio.

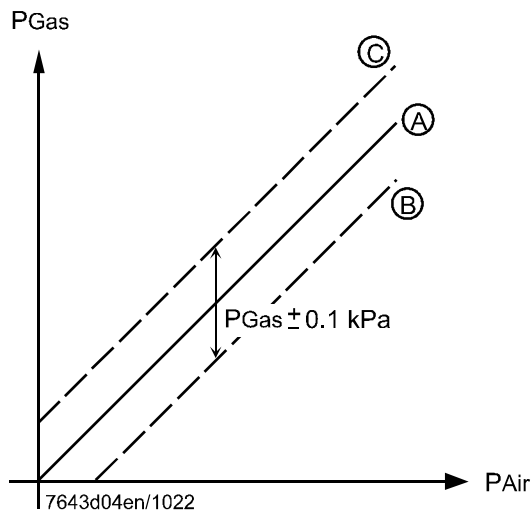
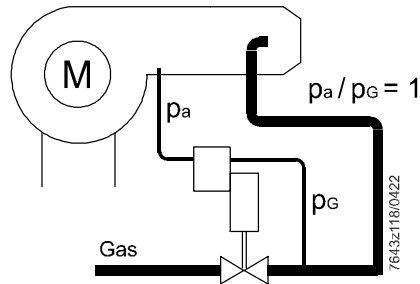

- Ⓐ Gas-air ratio for stoichiometric combustion
- Ⓑ / Ⓒ Parallel shift from gas pressure reduction Ⓑ toward gas pressure increase Ⓒ.

 **Note**  
Replace the cap before measuring the combustion value and after the setting is made.

**SKP25.4** <sup>1)</sup>

SKP25.4 is designed to manage higher pressures of up to 200 kPa.

Approved as a:

- Safety shutoff valve in accordance with EN 161
- Pressurestat in accordance with EN 88-2:AC5; EN 88-2:SG10 or ISO 23551-2

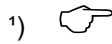

**Note!**  
SKP25.4 is not approved as an overpressure safety shutoff valve (SAV).

**SKP25.4** complete with valve

(Schematic drawing)

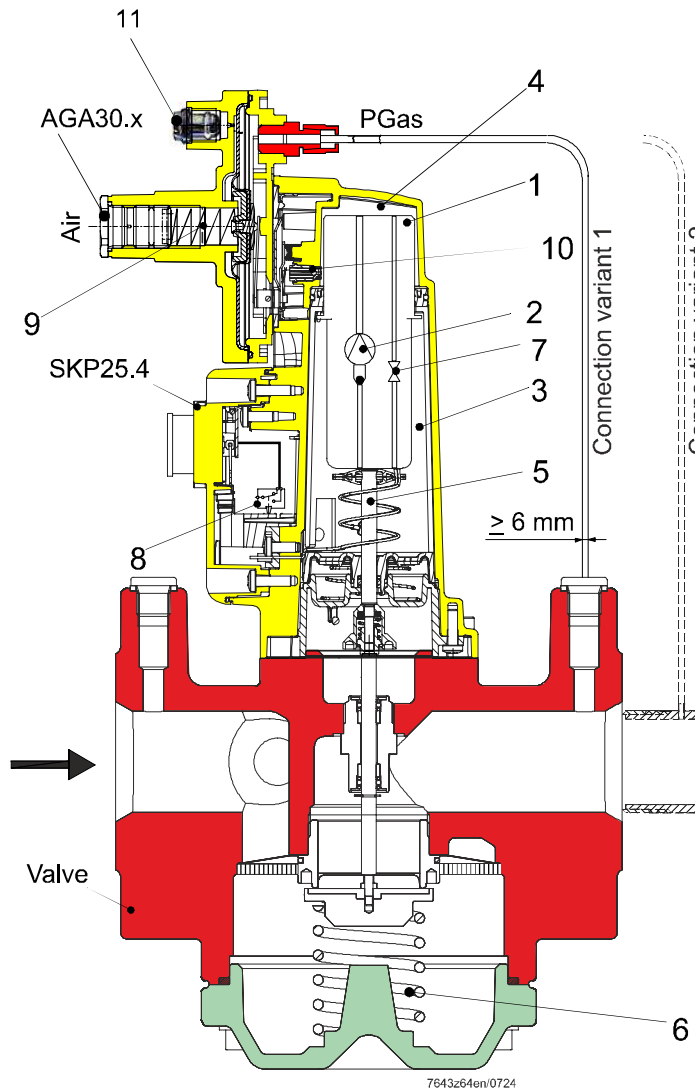

Legend

- 1...4 Electrohydraulic actuator
  - 5 Stem
  - 6 Valve's closing spring
  - 7 Control valve
  - 8 End switch, valve closed (optional)
  - 9 Spring (setpoint adjustment)
  - 10 Bypass valve
  - 11 Vent opening
- Optional:
- Mounting of an AGA25.2 or AGA25.3 damping throttle
  - The vent pipe must be connected (be sure to observe local requirements)!
  - AGA30.x Setting screw (setpoint adjustment)



**Please note:**  
All impulse pipes must be metallic.

**SKP25.4**

Setpoint adjustment «PGas» is made manually by turning the setting screw, which acts on the setpoint spring (for setpoint springs, also refer to «Accessories»).

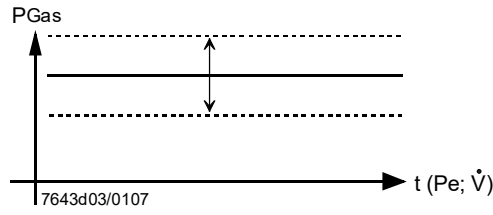

Legend

- Pe Inlet pressure
- $\dot{V}$  Volumetric flow
- PGas 7...200 kPa depending on the setpoint spring, see Accessories (with built-in standard spring AGA23), presetting 120 kPa

	Pressure range (kPa)	Setpoint spring	Setpoint spring with fine adjustment (optional)
1	7...70	AGA22	AGA30.0
2	15...150	AGA23	AGA30.1
3	20...200	---	AGA30.2

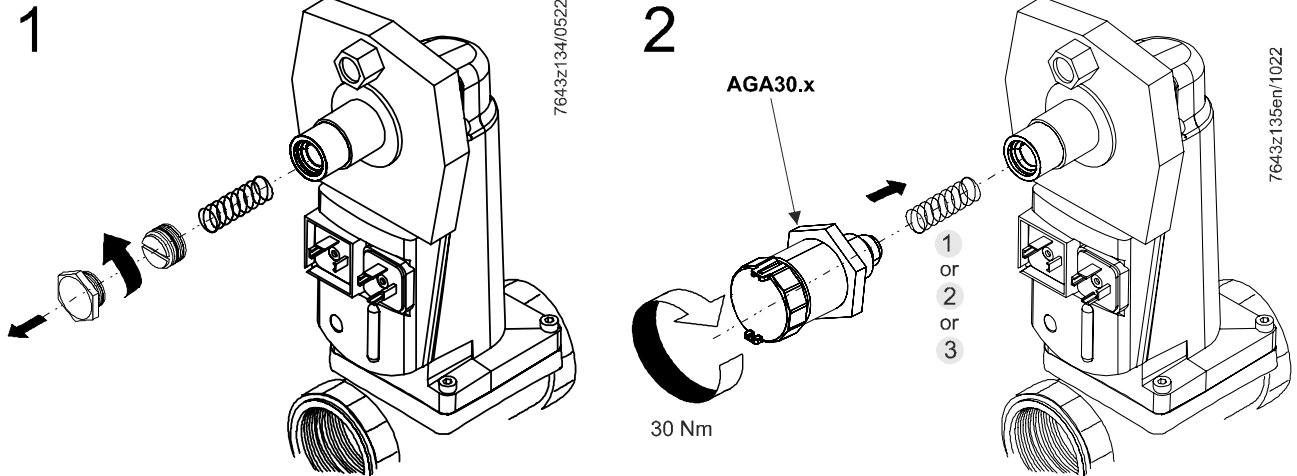

**SKP25.6**

The SKP25.6 (zero pressure governor) operates in the same way as the SKP25.3 but facilitates a larger parallel shift toward gas pressure reduction.

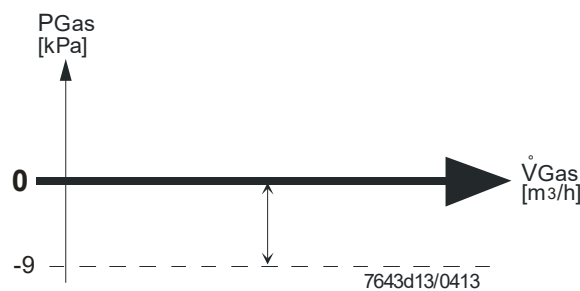
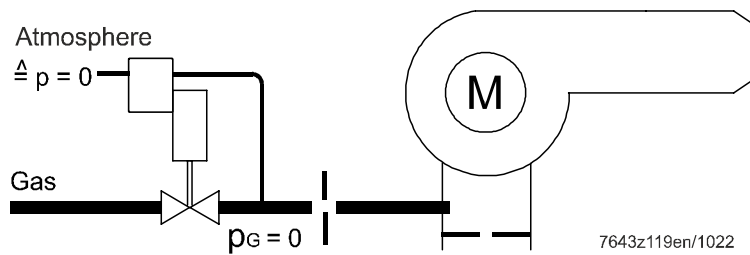

Key

- $\dot{V}$  Volumetric flow
- PGas Offset spring 0...0.9 kPa
- 0 Atmospheric pressure

**SKP55** The SKP55 operates with a differential pressure governor and a fixed differential pressure ratio of 1-to-1.

**SKP55** complete with valve (Schematic drawing)

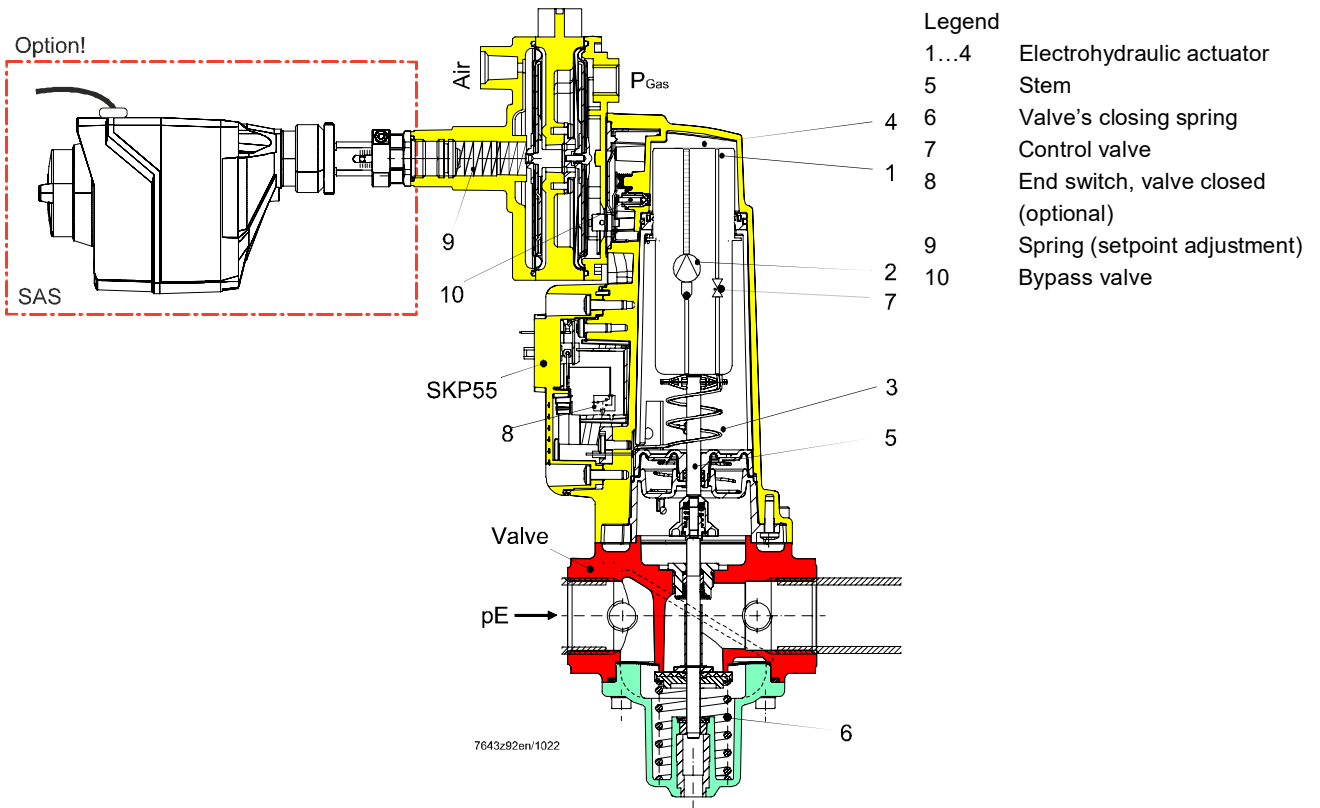

SKP55

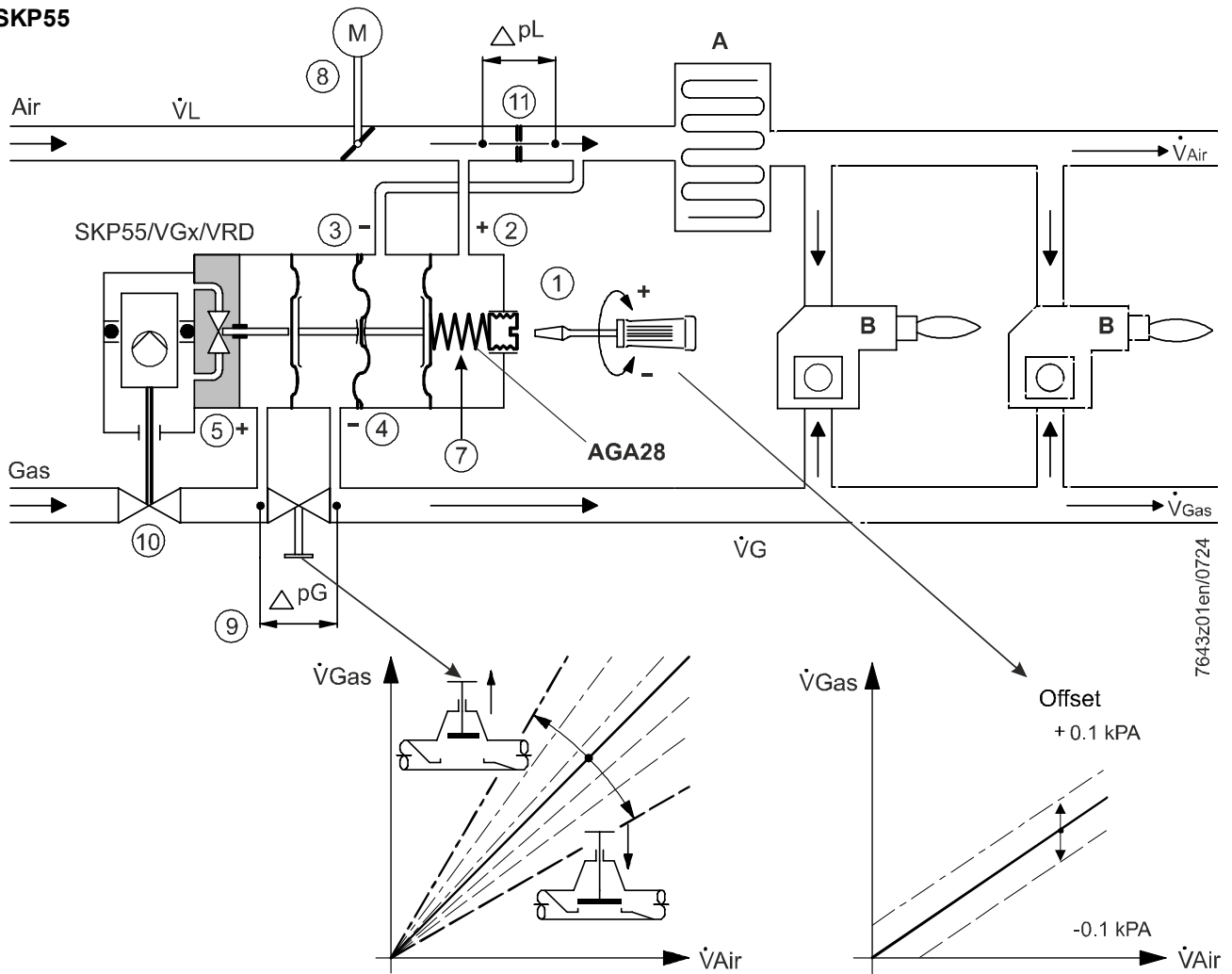

7643z01en/0724

Legend

- $\Delta p_G$  Differential pressure across orifice on the gas side
- $\Delta p_L$  Differential pressure across orifice on the air side
- A Air heating coil (recuperator)
- B Burner
- M Actuator
- ① Adjustment of parallel displacement of working characteristic  
\* Check combustion values with cap fitted
- ② Test point for air pressure (+)
- ③ Test point for air pressure (-)
- ④ Test point for gas pressure (-)
- ⑤ Test point for gas pressure (+)
- ⑦ Spring (parallel displacement)
- ⑧ Actuating device (air)
- ⑨ Orifice (gas)
- ⑩ Valve
- ⑪ Orifice (air)

**Safety notes:**



**Arrangement air damper ⑧ / orifice ⑪ must always be located as shown, which means that orifice ⑪ must be installed downstream from the air damper ⑧.**  
**Arrangement valve ⑩ (VGx/VRx) / orifice ⑨ must always be located as shown, which means that orifice ⑨ must be installed downstream from the valve ⑩.**



SKP55

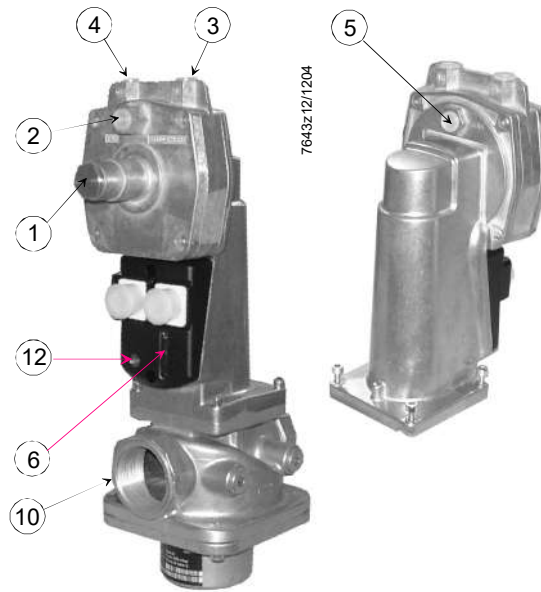

- ① Adjustment of parallel displacement of working characteristic  
\* Check combustion values with cap fitted
- ② Test point for air pressure (+)
- ③ Test point for air pressure (-)
- ④ Test point for gas pressure (-)
- ⑤ Test point for gas pressure (+)
- ⑥ Valve stroke indication
- ⑩ Valve
- ⑫ Indication of operating state (LED)

**SKP55**

Adjustment of governor on modulating burners prior to startup:

- Setting screw ① on the SKP55 should be set to a gas / air ratio curve which passes through the neutral point. The SKP55 is supplied with that factory setting. Adjustment in the field can be made as follows:

Note:



Fit cap again before measuring the combustion value and after the setting is made. Turn setting screw ① in counterclockwise direction until spring ⑦ is completely loose. Shut off the gas supply upstream of the SKP55. Switch on the SKP55. Turn setting screw ① in clockwise direction until valve opens

- Bring the adjustable orifice ⑨ to the precalculated value. That value with the same pressure differential on the air and gas side must lead to practically stoichiometric combustion
- Start the burner and run it to about 90 % of the high-fire
- Measure the combustion quality and make adjustments of the flow rate with the adjustable orifice ⑨ until optimum measured values are reached (fine adjustment)
- Return to low-fire operation. Check the combustion and readjust if necessary the position of the working characteristic with the setting screw ① on the SKP55 until optimum measured values are reached. Clockwise rotation → more gas. Counterclockwise rotation → less gas, that is, parallel displacement of the working characteristic towards gas pressure elevation or gas pressure lowering
- Limit the air damper ⑧ for low-fire operation
- If a parallel shift of the working characteristic was required, the adjustment to 90% high-fire operation must be checked again and corrected if necessary
- Run the burner to the intended high-fire with the help of the air damper ⑧ and limit the SKP55 position for that load
- Check the flue gas values at a few positions of the load range.

**SKP75**

The SKP75 operates with a ratio pressure governor and an adjustable gas / air ratio.

**SKP75** complete with valve

(Schematic drawing)

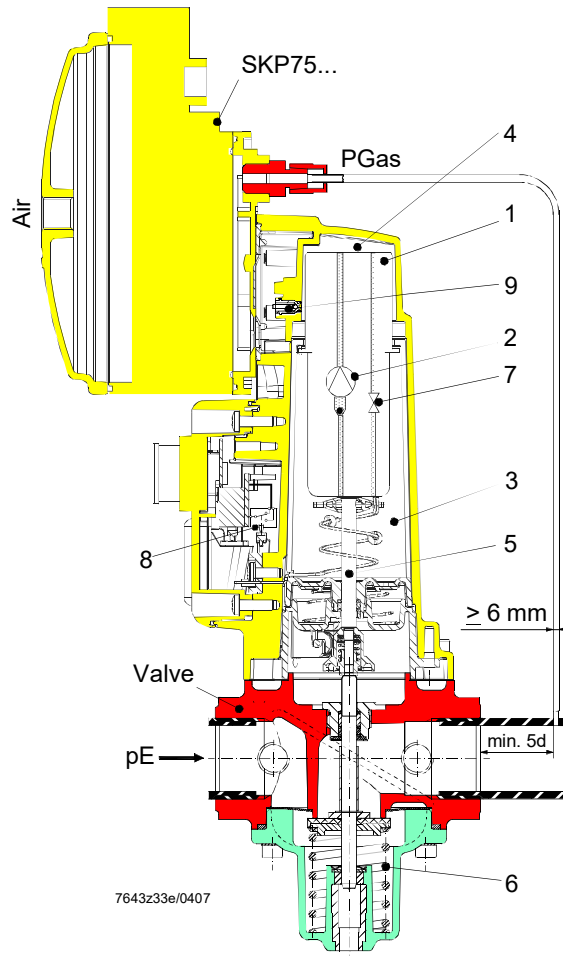

Legend

- 1...4 Electrohydraulic actuator
- 5 Stem
- 6 Valves closing spring
- 7 Control valve
- 8 End switch, valve closed (optional)
- 9 Bypass valve

Adjustment of governor on modulating burners

- Use setting screw ① / «PGAS» / «PAIR» to set the gas / air ratio to the required value (coarse setting) and the scale  with setting screw ② to zero (refer to Fig. 7643z03)





**Please note!**

**Adjusting the adjustment screws.**

The adjustment screws may only be adjusted by hand. An electric screwdriver is not permitted.

**Maximum torque (to stop): 1 Nm**

- Start the burner and run it to about 90 % of the high-fire
- Measure the CO<sub>2</sub> or O<sub>2</sub> content of the flue gases and optimize the adjustment with setting screw ① / «PGAS» / «PAIR»  (refer to Fig. 7643z03)
- Return to low-fire operation, check the CO<sub>2</sub> or O<sub>2</sub> content of the flue gases. If necessary, make corrections with the adjustment screw ② /  until the optimum measured values are attained
- Limit the air damper position for low-fire operation

Meaning of setting screw markings:



- + More gas
- Less gas

**SKP75**

If a parallel shift of the working characteristic was necessary to obtain optimum CO<sub>2</sub> or O<sub>2</sub> values in low-fire operation, the adjustment of the pressure ratio in high-fire operation or at 90% high-fire operation must be checked again and readjusted if required.

- Run the burner to the required output and limit the high-fire air damper position
- Check the flue gas values at various positions of the load range
- This would end the SKP75 setting

If subsequent corrections are necessary, the following applies:

- Use setting screw ① / «PGAS» / «PAIR»  in the high-fire range
- Use setting screw ② /  to make parallel displacements of the characteristic in the flow-fire range

If the gas / air pressure ratio lies outside the setting range, an orifice in the gas or air flow can be used to adjust the pressure at the test points on the burner side. Prerequisite is that there is a sufficient gas or air pressure reserve on the inlet side.

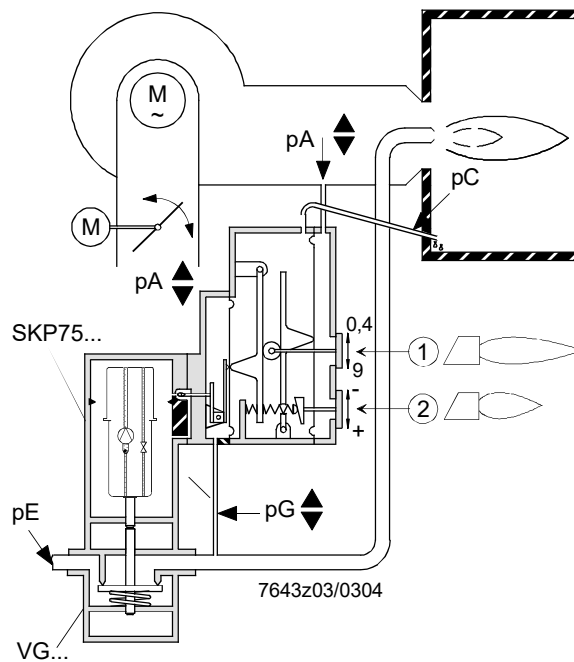

**SKP75**

- ① Setting and display of the gas / air ratio
- ② Setting and display of parallel displacement of the working characteristic
- ③ Test point for combustion chamber pressure
- ④ Test point for air pressure
- ⑤ Test point for gas pressure
- ⑥ Valve stroke indication
- ⑦ Operation indicator (LED)
- ⑧ Valve

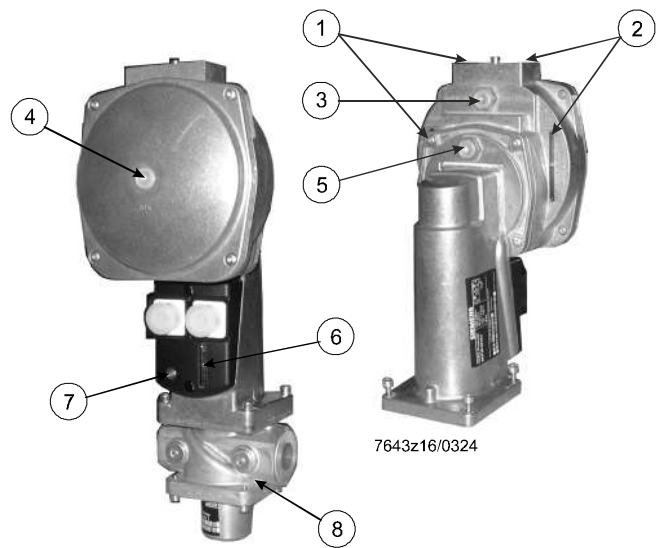

**Note**



The combustion chamber pressure must be connected if the gas/air ratio is not equal to 1:1. Non-proportional changes in the combustion chamber pressure in relation to the change in burner load are therefore taken into account.

**SKP75.0**

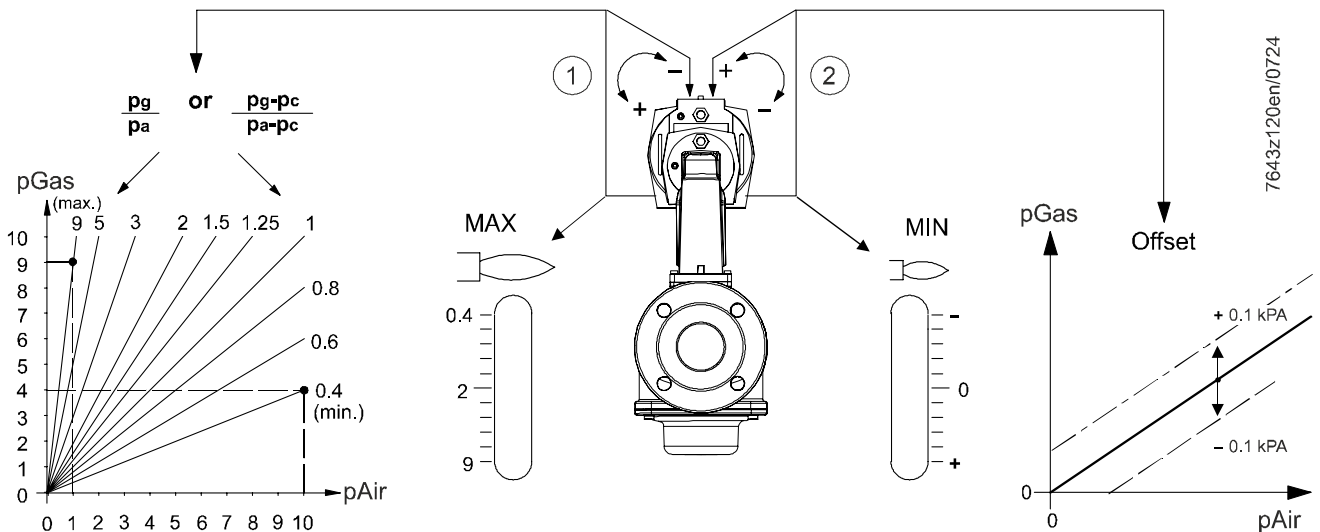

**Key**

- ① Setting and display of the gas-air ratio
- ② Setting and display of the parallel shift for the working characteristic

**Function**

If the air pressure (fan pressure) exceeds the maximum permissible value for the controller of

- 3 kPa with a P<sub>Gas</sub> / P<sub>Air</sub> ratio of  $\geq 2$
- 5 kPa with a P<sub>Gas</sub> / P<sub>Air</sub> ratio of  $\leq 2$

the pressure must be lowered with a pressure-reducing T-piece (AGA78) – also refer to chapter 'Accessories'.



Note

Only in connection with Siemens VGx/VRx valves.

In combination with VGx



**Applied directives:**

- Low-voltage directive 2006/95/EC
- Directive for pressure devices 2014/68/EU
- Gas Appliances Regulation (EU) (EU) 2016/426
- Electromagnetic compatibility EMC (immunity) \*) 2014/30/EU

\*) Compliance with EMC emissions requirements must be checked after the actuator has been installed in the work equipment

Compliance with the regulations of the applied directives is verified by the adherence to the following standards / regulations:

- Pressure regulators and associated safety devices for gas appliances  
Part 1:  
Pressure regulators for inlet pressures up to and including 50 kPa DIN EN 88-1
- SKP25.4 only DIN EN 88-2  
Pressure regulators and associated safety devices for gas appliances  
Part 2:  
Pressure regulators for inlet pressures above 500 mbar up to and including 5 bar
- Multifunctional controls for gas burning appliances DIN EN 126
- Automatic shut-off valves for gas burners and gas appliances DIN EN 161
- Safety and control devices for gas burners and gas burning appliances DIN EN 13611
- Automatic electrical controls for household and similar use Part 1:  
General requirements DIN EN 60730-1

**The relevant valid edition of the standards can be found in the declaration of conformity!**



EAC Conformity mark (Eurasian Conformity mark)





UKCA conformity mark (UK)



China RoHS  
Hazardous substances table:  
<http://www.siemens.com/download?A6V10883536>



For use in the US/Canada, the SKPx5s are identified with a 'U' (see example) and are approved by , , and  (for example: SKP25.003U1, refer to separate data sheets [available on request]).

## Life cycle

The combination valve and actuator have a designed lifetime\* of

Nominal size	Burner startup cycles
≤25 DN	200.000
25...80 DN	100.000
80...150 DN	50.000

which, under use of gases to EN 437 (or DVGW specification G260).

This lifetime is based on the endurance tests in the standard EN 161. A summary of the conditions has been published by the European Control Manufacturers Association (Afecor) ([www.afecor.org](http://www.afecor.org)).

The designed lifetime is based on use of the valve and actuator according to the manufacturer's Data Sheet. When reaching the designed lifetime in terms of the number of burner startup cycles or the respective time of usage, valve and actuator must be checked by authorized personnel and, if necessary, replaced.

\* The designed lifetime is not the warranty time specified in the Terms of Delivery.

## Disposal notes

The SKPx5 contains electrical and electronic components and hydraulic oil and must not be disposed of together with domestic waste. Local and currently valid legislation must be observed.

## Type summary (other types of actuators on request)

The complete gas shutoff assembly or pressure governor assembly consists of actuator and valve.

### SKP15

	Article no.	Type	Article no.	Type
Mains voltage	AC 120 V		AC 230 V	
1-stage opening and closing, without end switch, without valve stroke indication	BPZ:SKP15.000E1	SKP15.000E1	BPZ:SKP15.000E2	SKP15.000E2
1-stage opening and closing, with end switch, with valve stroke display	BPZ:SKP15.001E1	SKP15.001E1	BPZ:SKP15.001E2	SKP15.001E2

## Type summary (other types of actuators on request)

The complete gas shutoff assembly or pressure governor assembly consists of actuator and valve.

### SKP25

	Article no.	Type	Article no.	Type
Mains voltage	AC 120 V		AC 230 V	
1-stage opening and closing, with end switch, with pressure governor up to 2.2 kPa, other pressure ranges via change setpoint spring possible → refer to accessories	BPZ:SKP25.001E1 <sup>2)</sup>	SKP25.001E1 <sup>2)</sup>	BPZ:SKP25.001E2 <sup>2)</sup>	SKP25.001E2 <sup>2)</sup>
1-stage opening and closing, without end switch, with pressure governor up to 2.2 kPa, other pressure ranges via change setpoint spring possible → refer to accessories	BPZ:SKP25.003E1 <sup>2)</sup>	SKP25.003E1 <sup>2)</sup>	BPZ:SKP25.003E2 <sup>2)</sup>	SKP25.003E2 <sup>2)</sup>
1-stage opening and closing, without end switch, with pressure governor up to 2.2 kPa, other pressure ranges via change setpoint spring possible, with integrated damping throttle AGA25.2 → refer to Accessories	---	---	BPZ:SKP25.003E2Y	SKP25.003E2Y
2-stage opening and closing, with end switch, with pressure governor up to 6 kPa	BPZ:SKP25.201E1	SKP25.201E1	BPZ:SKP25.201E2	SKP25.201E2
2-stage opening and closing, without end switch, with pressure governor up to 2 kPa	BPZ:SKP25.201E1L	SKP25.201E1L	BPZ:SKP25.201E2L	SKP25.201E2L
2-stage opening and closing, without end switch, with pressure governor up to 6 kPa	---	---	BPZ:SKP25.203E2	SKP25.203E2
2-stage opening and closing, without end switch, with pressure governor up to 2 kPa	---	---	BPZ:SKP25.203E2L	SKP25.203E2L
1-stage opening and closing, with end switch, with stroke indication, proportionate governor version	---	---	BPZ:SKP25.301E2 <sup>*</sup> )	SKP25.301E2 <sup>*</sup> )
1-stage opening and closing, without end switch, proportionate governor version	---	---	BPZ:SKP25.303E2	SKP25.303E2
1-stage opening and closing, with end switch, with pressure governor up to 200 kPa, high-pressure version, other pressure ranges via change setpoint spring possible → refer to accessories	BPZ:SKP25.401E1 <sup>3)</sup>	SKP25.401E1 <sup>3)</sup>	---	---
1-stage opening and closing, without end switch, with pressure governor up to 200 kPa, high-pressure version, other pressure ranges via change setpoint spring possible → refer to accessories	BPZ:SKP25.403E1 <sup>2)</sup>	SKP25.403E1 <sup>2)</sup>	BPZ:SKP25.403E2 <sup>2)</sup>	SKP25.403E2 <sup>2)</sup>
1-stage opening and closing, with end switch, for zero pressure governor version	---	---	BPZ:SKP25.601E2 <sup>*</sup> )	SKP25.601E2 <sup>*</sup> )
1-stage opening and closing, without end switch, for zero pressure governor version	---	---	BPZ:SKP25.603E2 <sup>*</sup> )	SKP25.603E2 <sup>*</sup> )

<sup>1)</sup> Factory setting 1.5 kPa

<sup>2)</sup> Factory setting 120 kPa

<sup>\*</sup>) On request



## Type summary (other types of actuators on request)

### SKP55

	Article no.	Type	Article no.	Type
<b>Mains voltage</b>	<b>AC 120 V</b>		<b>AC 230 V</b>	
1-stage opening and closing, with end switch, with differential pressure governor	<b>BPZ:SKP55.001E1</b>	<b>SKP55.001E1</b>	<b>BPZ:SKP55.001E2</b>	<b>SKP55.001E2</b>
1-stage opening and closing, without end switch, with differential pressure governor	<b>BPZ:SKP55.003E1</b>	<b>SKP55.003E1</b>	<b>BPZ:SKP55.003E2</b>	<b>SKP55.003E2</b>

### SKP75

	Article no.	Type	Article no.	Type
<b>Mains voltage</b>	<b>AC 120 V</b>		<b>AC 230 V</b>	
1-stage opening and closing, with end switch, with ratio pressure governor	<b>BPZ:SKP75.001E1</b>	<b>SKP75.001E1</b>	<b>BPZ:SKP75.001E2</b>	<b>SKP75.001E2</b>
1-stage opening and closing, without end switch, with ratio pressure governor	<b>BPZ:SKP75.003E1</b>	<b>SKP75.003E1</b>	<b>BPZ:SKP75.003E2</b>	<b>SKP75.003E2</b>
1-stage opening and closing, with end switch, with ratio pressure governor, with greater parallel displacement	---	---	<b>BPZ:SKP75.501E2</b>	<b>SKP75.501E2</b>

<sup>2)</sup> Factory setting 1.5 kPa

## Ordering examples

Please provide the complete type reference of the SKPx5 – refer to the *Type summary* chapter. All components must be ordered as separate items.

### Example of SKP15

Actuator with safety shutoff function

- Open / closed
  - With end switch
  - For AC 230 V / 50 Hz
- Connector valve actuator (plug) **SKP15.001E2**  
**AGA64**  
 Connector end switch (plug) **AGA65**

Combination of SKPx5 and valve comprising:

- Valve
- SKP15.001E2 actuator
- Accessories

Order the required valves as separate items – refer to the relevant data sheets. The SKPx5 and the valve are supplied separately. Assembly is very straightforward and preferably made on the burner.

### Example of SKP25

Gas pressure governor with safety shutoff function:

- Without end switch
  - For AC 230 V / 50 Hz
- Connector valve actuator (plug) **SKP25.003E2**  
**AGA64**

Combination of SKPx5 and valve comprising:

- Valve
- SKP25.003E2 actuator



**Adapter plug**

**AGA62.000A000**

Article no.: **BPZ:AGA62.000A000**

For powering both SKPx5s on the valve (VGDx/VRDx) with a connector (AGA64).

Example: SKP15 / SKP25.2 with adapter plug AGA62.000A000

Central connection via AGA64 for the **separate** control of valves 1 and valves 2  
Facilitates valve proving via pressure switch between the valves or ignition via pilot burner

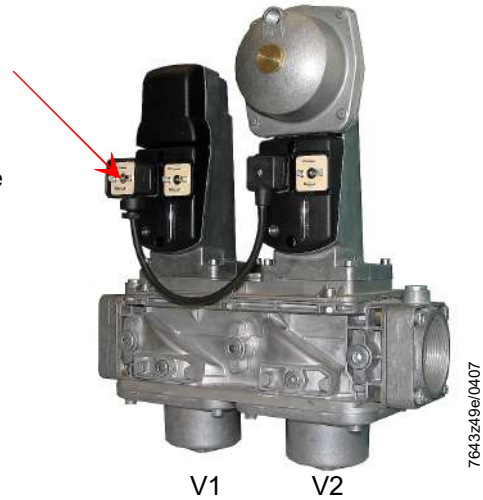

**Heating element**

**AGA63.6A27**

Article no.: **S55851-Z701-A100**

- For use at low ambient temperatures (-20...+15°C)
  - The AGA63.6 heating element is suitable for all SKPx5 types
  - The AGA63.6 heating element is supplied with 3 tension springs for fastening
- Refer to Data Sheet N7924.





**Contact box for valve actuator (power supply)**

**AGA64**

Article no.: **BPZ:AGA64**

- Plug-in connector conforming to EN 175301-803-A
- 3 pole +  $\oplus$
- Dia. 6...9 mm / max. 1.5 mm<sup>2</sup> / Pg11

Example: SKP15 / SKP25 with contact box AGA64



**Contact box for end switch**

**AGA65**

Article no.: **BPZ:AGA65**

- Plug-in connector conforming to EN 175301-803-A
- 3 pole +  $\oplus$
- Dia. 4.5...9 mm / max. 1.5 mm<sup>2</sup> / Pg11

Example: SKP15 / SKP75 with contact box AGA65

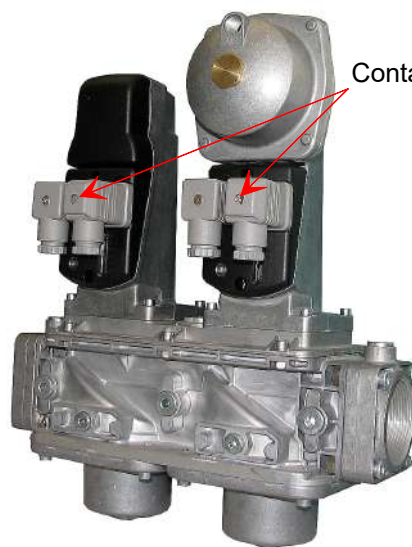

Contact box end switch AGA65

V1 V2

7643250e/0407

**Contact box**

**AGA67**

Article no.: **BPZ:AGA67**



- For the power supply to the SKP25.2
- Plug-in connector conforming to EN 175301-803-A
- With integrated bridge rectifier
- 2 pole +  $\oplus$
- Dia. 6...8 mm / max. 1.5 mm<sup>2</sup>
- Including profile seal

Example: SKP15 / SKP25 with contact box AGA67

Contact box AGA67



**Adapter plug for AGA62.000A000**

**AGA68**

Article no.: **BPZ:AGA68**





For common valve control

Example: SKP15 / SKP25 with adapter plug AGA68

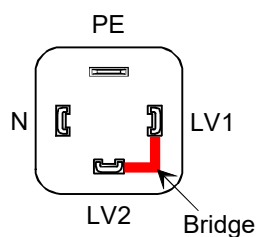
Adapter plug AGA68



**Accessories** (not supplied as standard, to be ordered as separate items) (cont'd)

	Article no.	Type
 <p><b>Motorized setpoint adjuster</b> for SKP25.0</p> <ul style="list-style-type: none"> <li>• For 5.5 mm stroke</li> <li>• Refer to Data Sheet N4581</li> </ul>		<b>SAS...</b>
 <p><b>Adaptation</b> to SKP25 For motor pressure correction in conjunction with motorized setpoint adjuster SAS.</p>	<b>S55851-Z401-A100</b>	<b>AGA30.7</b>
 <p><b>Damping throttle</b> for SKP25</p> <ul style="list-style-type: none"> <li>• Standard version: Nozzle cross section for pressures greater than 2 kPa</li> <li>• Optional: Nozzle cross section for pressures less than 2 kPa</li> </ul>	<b>BPZ:AGA25.2</b>  <b>S55851-Z303-A100</b>	<b>AGA25.2</b>  <b>AGA25.3</b>
<p><b>Damping throttle</b> for SKP55 / SKP75 Optional, pipe connection for 6 mm dia.</p>	<b>BPZ:AGA75</b>	<b>AGA75</b>

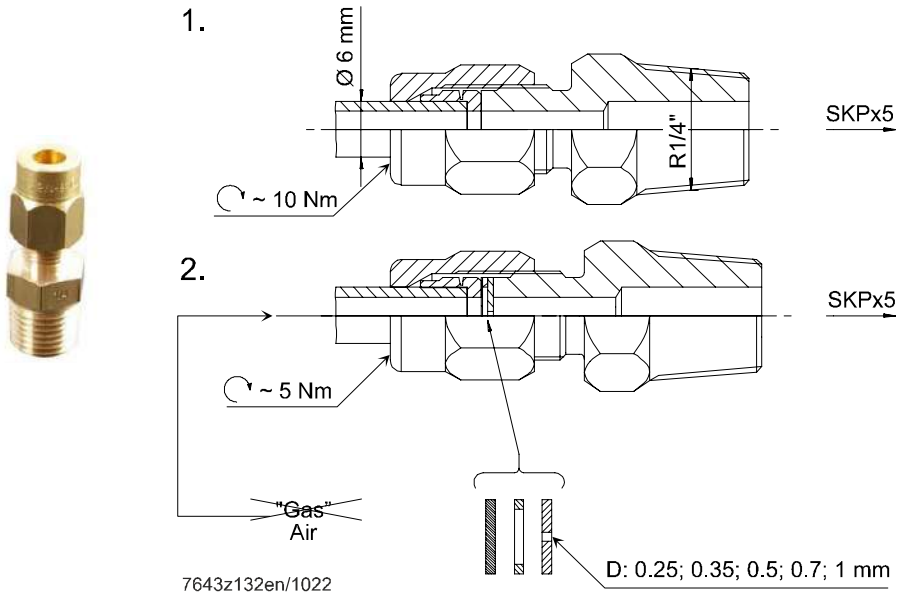

**Accessories** (not supplied as standard, to be ordered as separate items) (cont'd)



**Pressure-reducing T-piece** for SKP75  
Optional

Article no.	Type
BPZ:AGA78	AGA78

- 3 kPa with a  $P_{Gas} / P_{Air}$  ratio of  $\geq 2$
- 5 kPa with a  $P_{Gas} / P_{Air}$  ratio of  $\leq 2$

permitted for the controller, the pressure must be lowered with a pressure-reducing T-piece (AGA78) (also refer to *Technical data*).

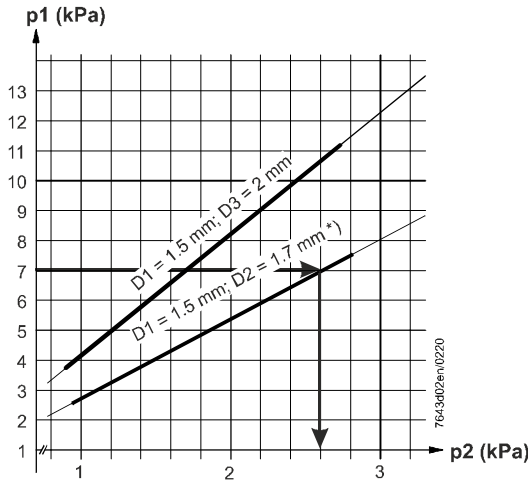

Example:  
 $p_1 = 7 \text{ kPa}$   
 $D_1 = 1.5 \text{ mm}$   
 $D_2 = 1.7 \text{ mm}$

Wanted: Air pressure signal « $p_2$ » for SKP75  
 $p_2 = 2.6 \text{ kPa}$

\*) Factory setting

Air is continuously vented to the atmosphere via the damper (D2). The pressure of the following medium will be reduced via throttle «D1». The illustration below shows the correlations.

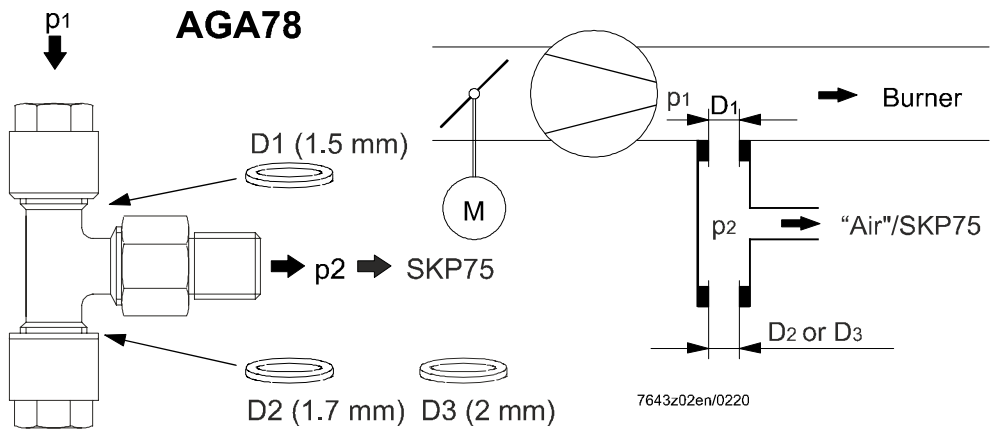

The pressure-reducing T-piece AGA78 is supplied ready for mounting, with  $D_1 = 1.5 \text{ mm}$  and  $D_2 = 1.7 \text{ mm}$ .  $D_3$  with a diameter of 2 mm is included as a loose item.

**Accessories** (not supplied as standard, to be ordered as separate items) (cont'd)

Overview of the setpoint springs:



Pressure range	Color	Wire diameter in mm	Actuator			Note / Accessories	Article no.	Type
			SKP25.0	SKP25.3	SKP25.4			
0.5...3.5 kPa 2.5...5.5 kPa	Black	1	●	---	---	When used with AGA30.7	<b>S55851-Z301-A100</b>	<b>AGA21</b>
1.5...12 kPa	Yellow/Gold	1.5	●	---	---	Optional with AGA30.0	<b>BPZ:AGA22</b>	<b>AGA22</b>
7...70 kPa		1.5	---	---	●	Optional with AGA30.0		
10...25 kPa	Red	1.8	●	---	---	Optional with AGA30.1	<b>BPZ:AGA23</b>	<b>AGA23</b>
15...150 kPa		1.8	---	---	●	Optional with AGA30.1		
0.2...5.5 kPa 1.7...7 kPa	Copper	1.4	●	---	---	When used with AGA30.7	<b>S55851-Z302-A100</b>	<b>AGA26</b>
±0.15 kPa	Unpainted	0.6	---	●	---	---	<b>BPZ:AGA28</b>	<b>AGA28</b>
0.05...2.2 kPa	Unpainted	1.0	●	---	---	---	<b>BPZ:AGA29</b>	<b>AGA29</b>
10...36 kPa	Unpainted	2.0	●	---	---	Only when used with AGA30.2 Spring 7421500490 included	<b>BPZ:AGA30.2</b>	<b>AGA30.2</b>
30...200 kPa		2.0	---	---	●	Only when used with AGA30.2 Spring 7421500490 included		

7643z45e/0407



**Gasket set**

- For mounting between the SKPx5 and the valve (VGx/VRx)
- Increases degree of protection from IP54 to IP65
- When using VGG single valves, data sheet N7636 must be observed

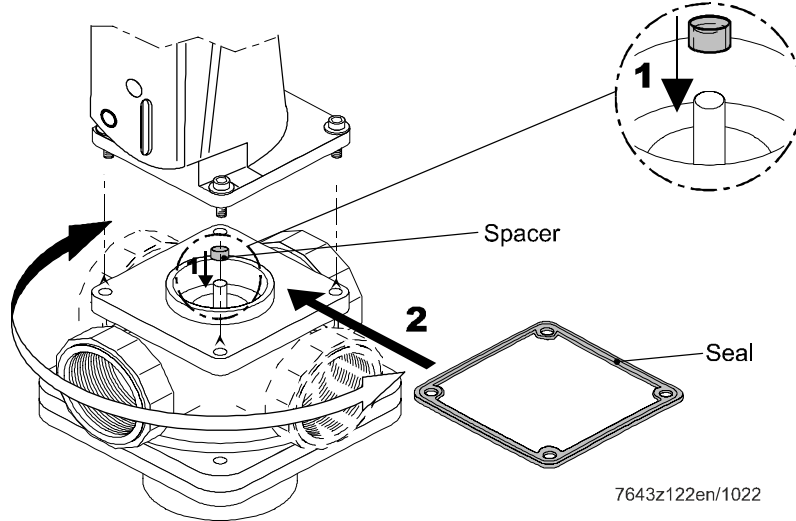

**Please note!**

**The seal and the spacer must be mounted!**



**The seal must be mounted with its profile side facing the SKPx5. A suitable cable gland (SKPx5.xxxUx / NPSM liquid tight) or a suitable connector with a seal (SKPx5.xxxEx / AGA64 or AGA65) must be used. In conjunction with the VGG, refer to Data Sheet N7636 (flow restriction).**





**Setpoint fine adjustment to SKP25**  
Packaging version with one setpoint spring each.

**AGA30.x**

Article no.	Type	Setpoint spring		
		1.5...12 kPa Color: Yellow 1	10...25 kPa Color: Red 2	10...36 kPa Color: Blank 3
BPZ:AGA30.0	AGA30.0	•		
BPZ:AGA30.1	AGA30.1		•	
BPZ:AGA30.2	AGA30.2			•

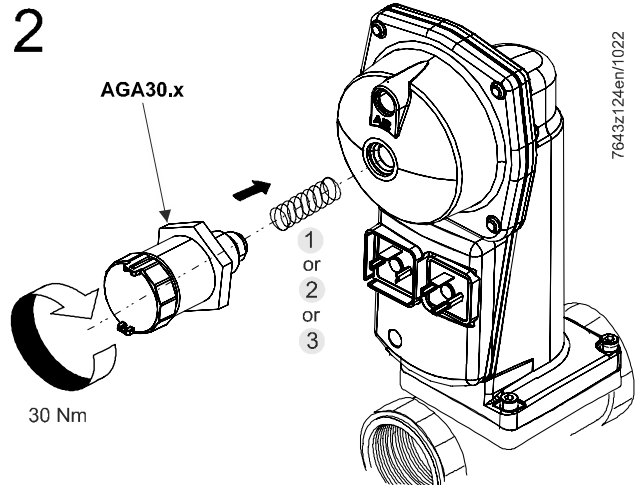
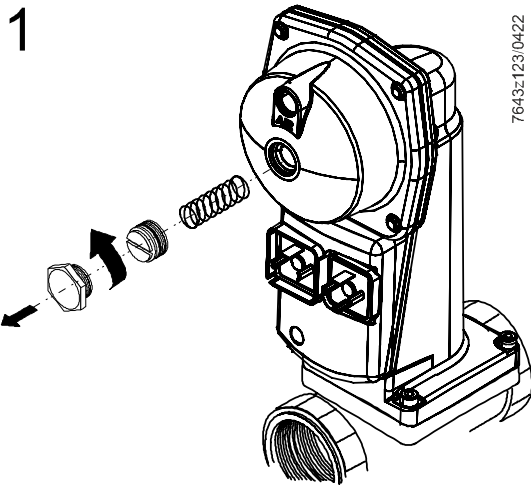
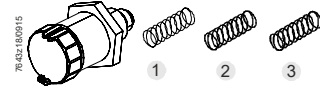

## Technical Data



**Note!**  
All typical technical information applies to nominal conditions.

### General unit data

Mains voltage	
Europe	
→ SKPx5.xxxE2	AC 230 V –15%/+10%
→ SKPx5.xxxE1	AC 120 V –15%/+10%
Japan	
→ SKPx5.xxxF1	AC 100 V –15%/+10%
→ SKPx5.xxxF2	AC 200 V –7%/+10%
Mains frequency	
• Europe	50 / 60 Hz ±6%
• Japan	60 Hz ±6%
Power consumption	Protection 1 A slow
European	
→ SKPx5.xxxEx	Max. 10 VA
→ SKP25.2xxEx	Max. 35 VA (in stage 2)
Japan	
→ SKPx5.xxxFx	Max. 13 VA
Closing time	
→ SKPx5	<1 s (at shutdown)
Required time interval load change carried via air / fuel ration pressure between high-fire and low-fire	
→ SKP25.3 / SKP55 / SKP75	Min. 4 s (depending on valve stroke)
Safety class	I
Degree of protection	
→ SKPx5	<b>IP54</b> → only ensured when central screw at the connector is tightened
	<b>IP65</b> → only with gasket kit AGA66
→ SKP25 / SKP55	→ only with screwed-on locking caps



**Note!**  
Degree of protection IP54 and IP65 only possible with mounted connectors.

Pollution degree	2
Rated surge voltage	Overvoltage category III in accordance with DIN EN 60730-1
Mode of operation	Automatic controller and control unit: Type 2C
Design of the controller and control unit	Integrated controller and control unit
Control class	A to DIN EN 88-1
→ SKP25.4	
• Accuracy class	In accordance with EN 88-2:AC5
• Closing pressure class	In accordance with EN 88-2:SG10
Control accuracy	
→ SKP75	<10 % at «Δpmin», <2 % at «Δpmax»
→ SKP55	<10 % at «Δpmin», <1 % at «Δpmax»

## Technical Data (cont'd)

Permissible operating pressure or permissible gas pressure at the connection point	
→ SKP25.0	Max. 120 kPa
→ SKP25.2	Max. 120 kPa
→ SKP25.3	Max. 120 kPa
→ SKP25.6	Max. 120 kPa
→ SKP55	Max. 120 kPa
→ SKP75	Max. 120 kPa

### Control variable gas pressure

→ SKP25.0	0.05...25 kPa (3 setpoint springs)
→ SKP25.2	0.2...6 kPa
→ SKP25.2xxxxL	0.2...2 kPa
→ SKP25.3	0.05...5 kPa
→ SKP25.4	7...200 kPa (3 setpoint springs)
→ SKP25.4 with AGA30.2	2...36 kPa
→ SKP25.6	<0 kPa (atmosphere)
→ SKP55	Difference pressure PG+ / PG- 0.03...20 kPa
→ SKP75 / SKP75.5	Difference pressure PG-PF or PG-PAir 0.08...12 kPa

### Absolute / difference pressure of combustion air (reference variable)

→ SKP25.3	0.05...7.5 kPa
→ SKP55	Difference pressure PL+ / PL- 0.03...20 kPa
→ SKP75 / SKP75.5	PAir-PCombustion space >0.05 kPa

### Air pressure / difference pressure

- at  $\langle P_{Gas} / P_{Air} \rangle \geq 2$  Max. 3 kPa
- at  $\langle P_{Gas} / P_{Air} \rangle \leq 2$  Max. 5 kPa
- For higher pressures, refer to AGA78 Max. 15 kPa  
in the *Accessories* chapter

### Difference pressure ratio (gas / air) adjustable

→ SKP25.3 / SKP55	1:1
→ SKP75 / SKP75.5	0.4...9 (Factory supplied 1.3)

### Permissible combustion space pressure

→ SKP75	3 kPa
---------	-------

### Parallel shift P<sub>Gas</sub> (typical)

→ SKP25.3 / SKP55	±0.09 kPa
→ SKP25.6	0 kPa/-0.9 kPa
→ SKP75	±0.1 kPa (Factory supplied 0)
→ SKP75.5	+0.1 kPa/-0.45 kPa (Factory supplied 0)

### Position switch (if built-in)

	Factory set as a fully closed position switch (end switch)
	Position valve CLOSED or OPEN
- Switching load	4 A (2 A, $\cos\varphi = 0.3$ ) Protection 6 A slow



### Notice!

**Safety extra-low voltage may not be connected.**

**If this is not observed, there will be a risk of electric shock!**

On-time	100 %
Opening speed, typical (approx. 2 mm/s)	Lower opening speeds due to low ambient temperatures can be compensated by fitting an AGA63.6A27 heating element

Permissible mounting positions

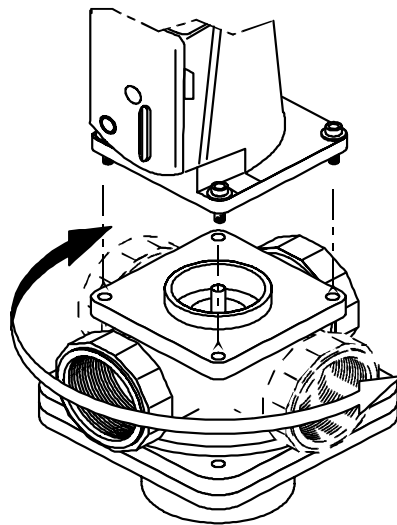

Always with the diaphragms in the vertical position

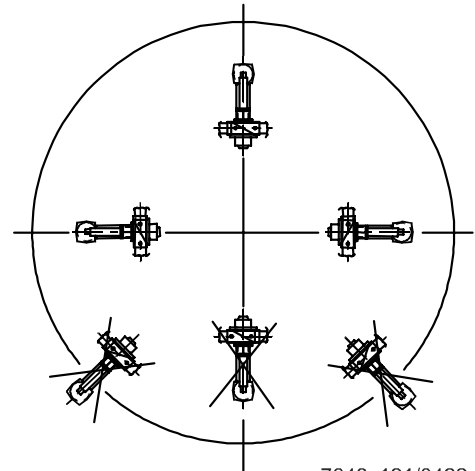

7643z121/0422

Weight

→ SKP15	Approx. 1.1 kg
→ SKP25	Approx. 1.6 kg
→ SKP25.0	Approx. 1.6 kg
→ SKP25.2	Approx. 2.1 kg
→ SKP55	Approx. 1.9 kg
→ SKP75	Approx. 2.3 kg
→ AGA64	Approx. 30 g
→ AGA65	Approx. 36 g
→ AGA62.000A000	Approx. 66 g

Permissible media Depending on used valve

Media inlet pressure «PE» Depending on used valve

Permissible media temperature Depending on used valve

Flow rate Depending on used valve

Permissible test pressure «PG» 100 kPa

Permissible under pressure «PG» 20 kPa

Gas family I...III

## Technical Data (cont'd)

---

### Environmental conditions

<b>Storage</b>	EN 60721-3-1:1995 + A2:1997
Climatic conditions	Class 1K3
Mechanical conditions	Class 1M2
Temperature range	-15...+60 °C
Humidity	<95 % r.h.
<b>Transport</b>	EN 60721-3-2:1995 + A2:1997
Climatic conditions	Class 2K2
Mechanical conditions	Class 2M2
Temperature range	-15...+60 °C
Humidity	<95 % r.h.
<b>Operation</b>	EN 60721-3-3:1995 + A2:1997
Climatic conditions	Class 3K3
Mechanical conditions	Class 3M3
→ SKP25.0 with AGA30.7 and SAS	See <i>Use</i>
	No classification «-M-» (restricted operating conditions)
Temperature range	-10...+60 °C (longer opening times below 0 °C) -20...+60 °C (with heating element AGA63.6A27)
Temperature range	-5...+55 °C
Mechanical conditions	
→ SKP25.2	-10...+50 °C (restricted operating conditions)
→ SKP25.0 with AGA30.7 and SAS	-4...+54 °C (restricted operating conditions)
Humidity	<95 % r.F.
Installation altitude	Max. 2,000 m above sea level

---

Connection to the SKPx5 (front-view)

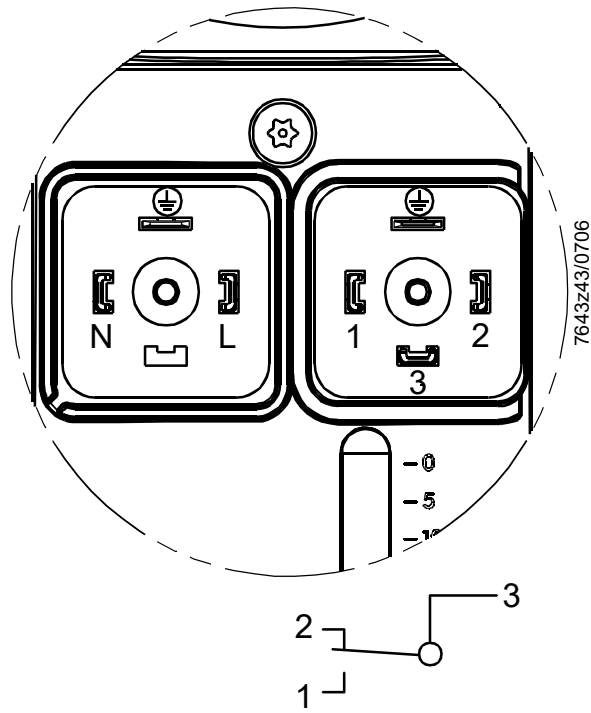

**Valve actuator**  
Connection via AGA64  
EN 175301-803-A



**End switch**  
Connection via AGA65  
EN 175301-803-A



← If valve closed

(Only with SKPx5.xx1xx)

**Dimensions**

Dimensions in mm

**SKP15**

Example: SKP15.000

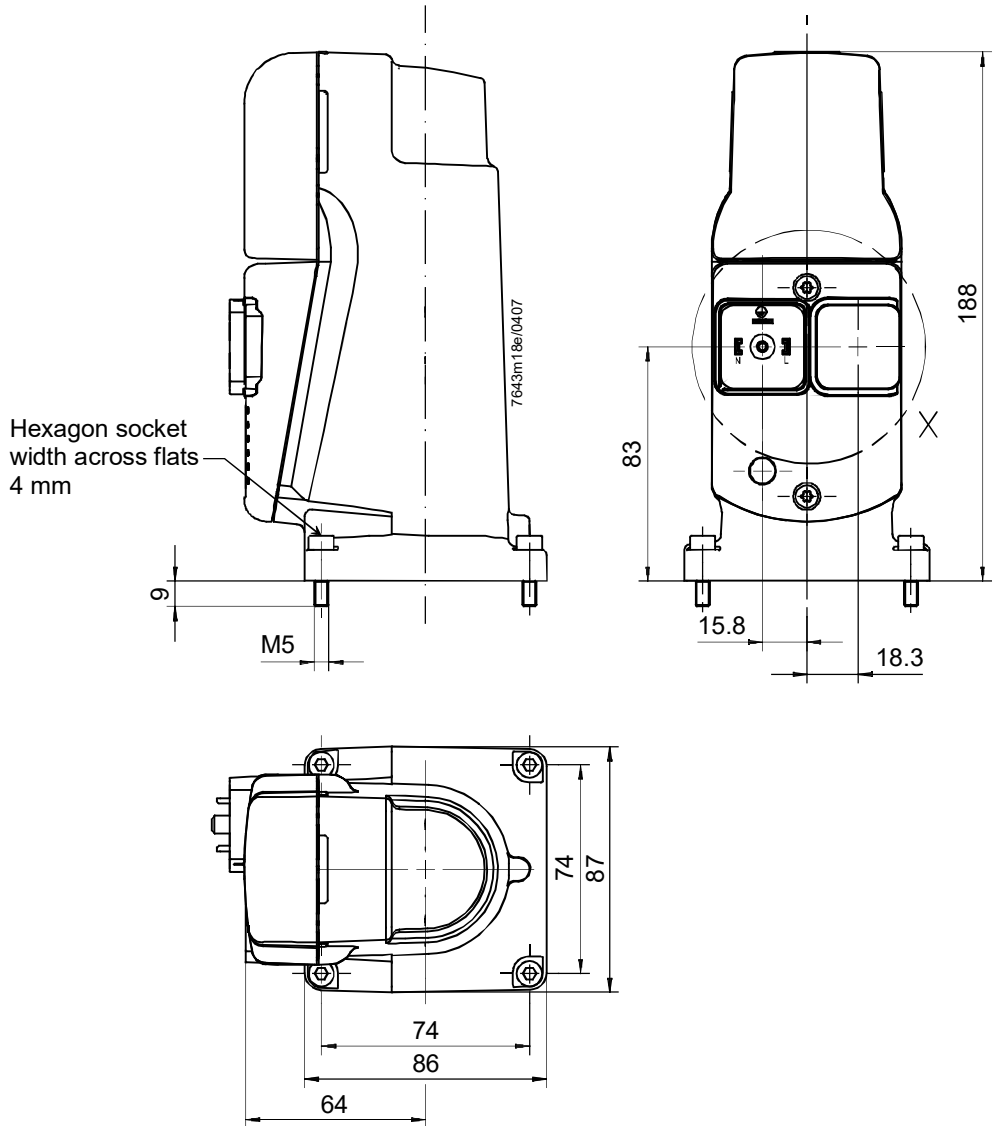

**SKP15.000 (no valve stroke indication)**

**SKP15.001**

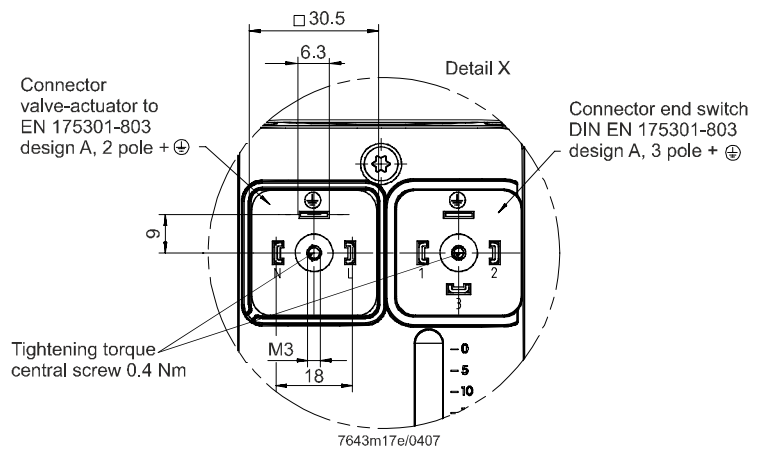
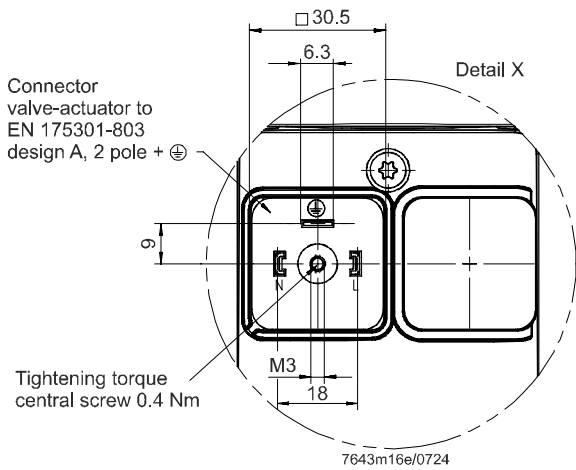

Dimensions in mm

**SKP25.0 / SKP25.3 / SKP25.6**

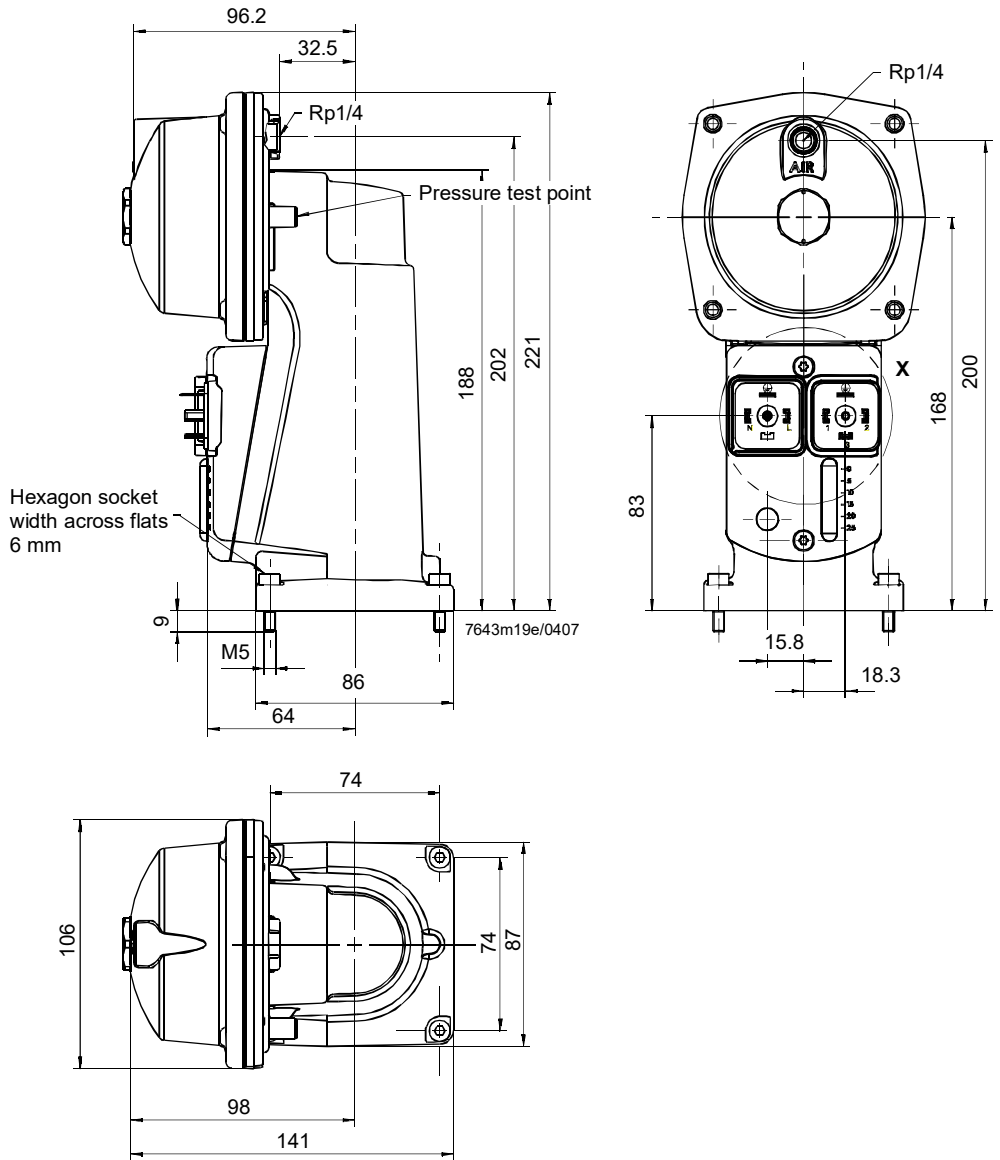

**SKP25.001**

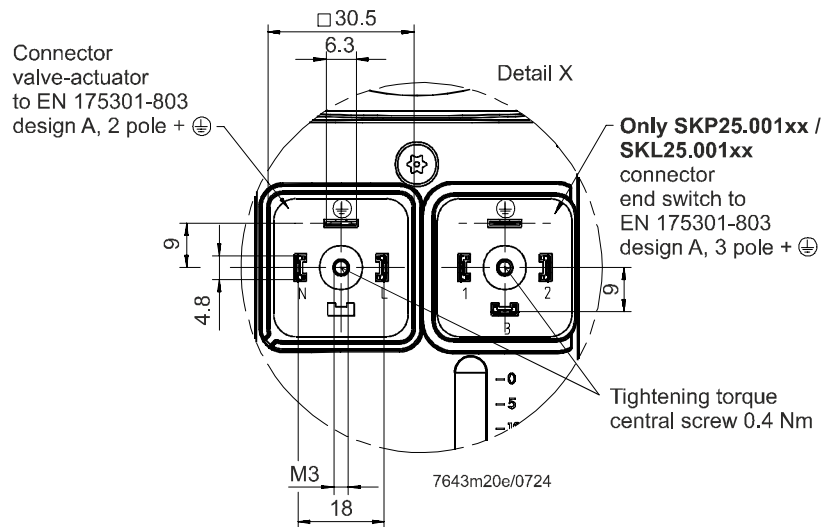



**Dimensions** (continued)

Dimensions in mm

**SKP25.0** (with AGA30.7  
and SAS)

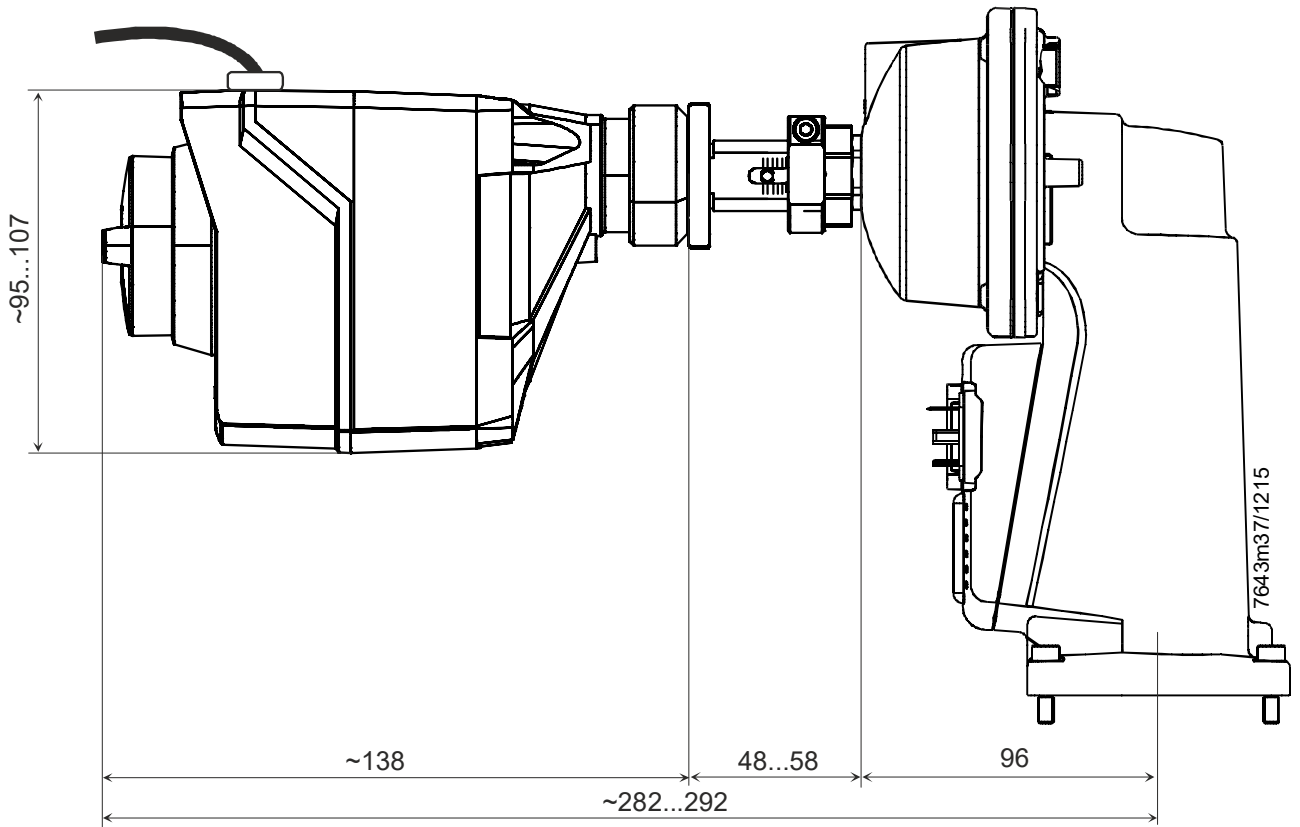

Dimensions in mm

SAS motorized setpoint adjuster

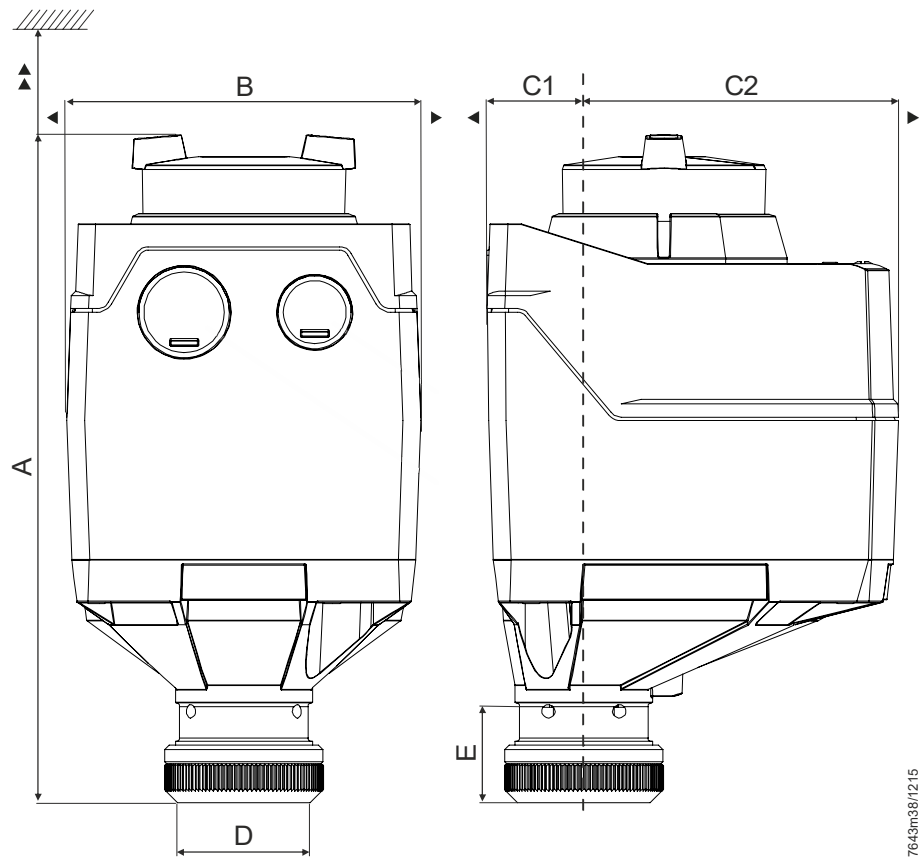

7643m38/1215

Type	A	B	C	C1	C2	D	E	▶	▶▶	Kg
Without ASK39.2	137.6 <sup>1)</sup> 151 <sup>2)</sup>	80	106.5	21.9	84.6	29.9	21.8	100	200	0.68

Dimensions in mm

**SKP25.2**

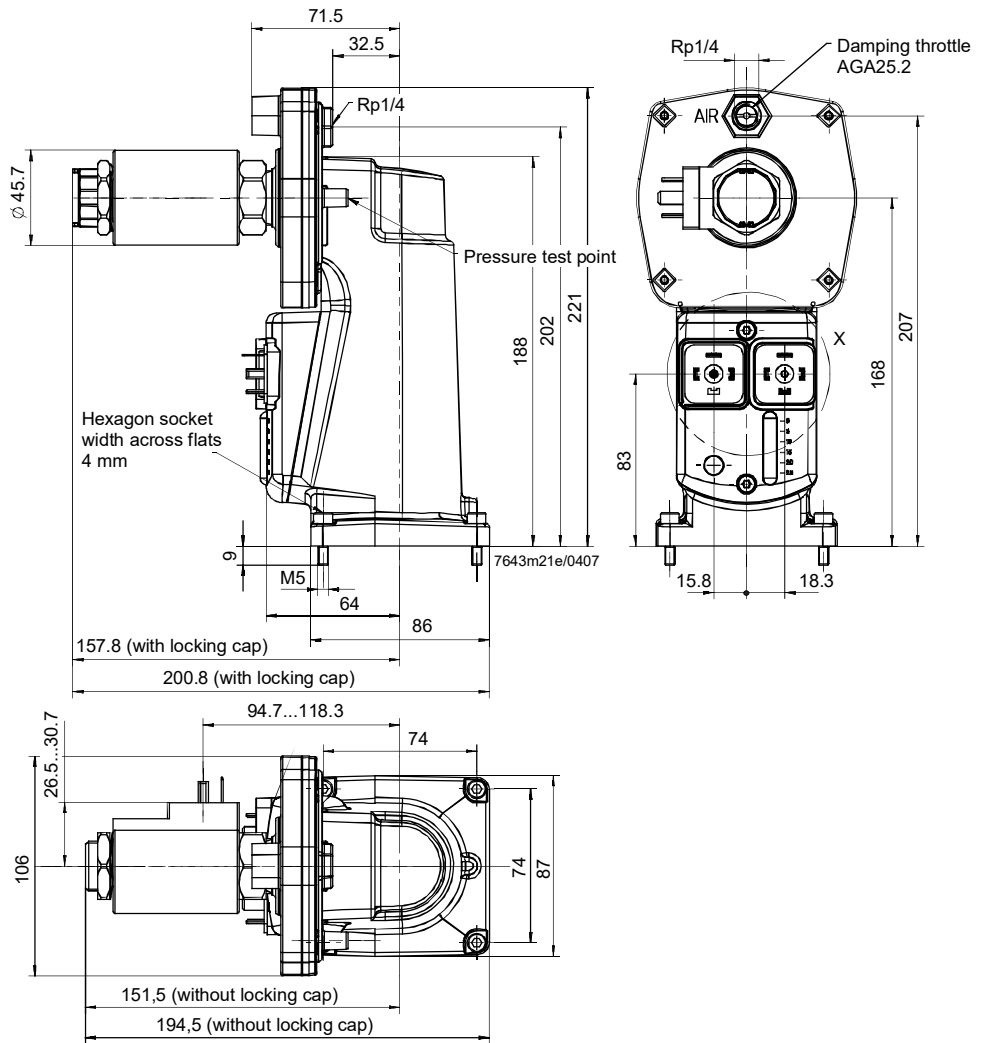

**SKP25.201**

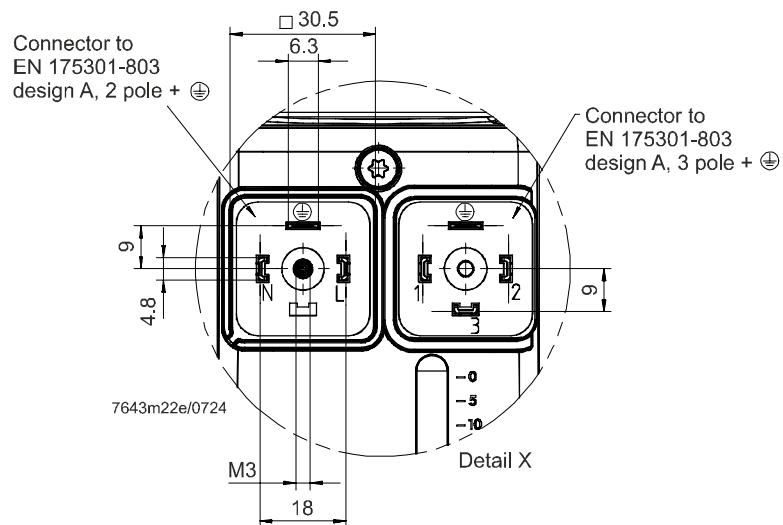

Dimensions in mm

**SKP25.4**

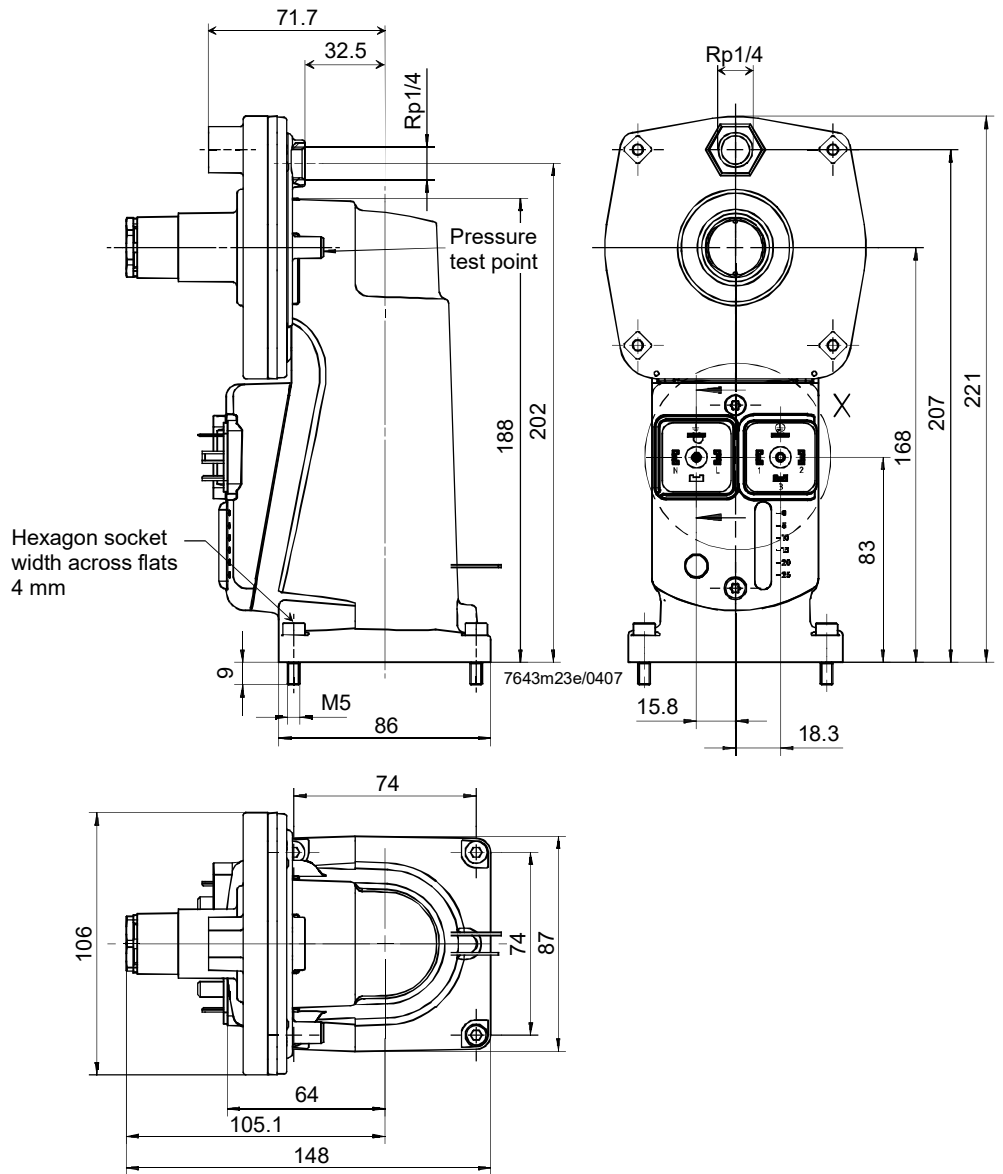

**SKP25.401E1**

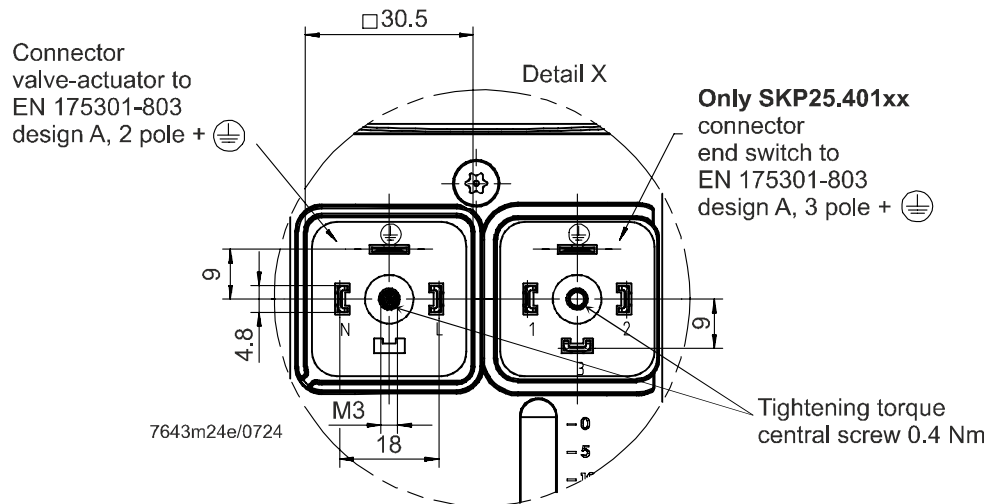

Dimensions in mm

**SKP55**

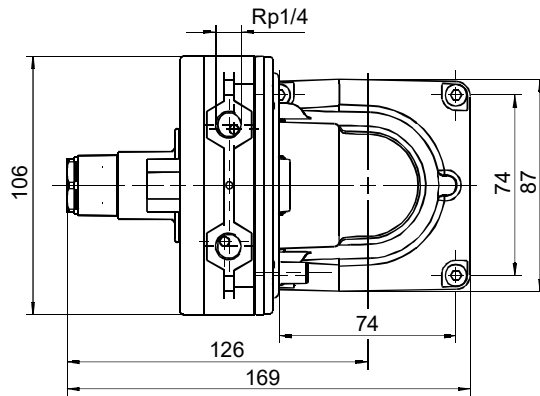
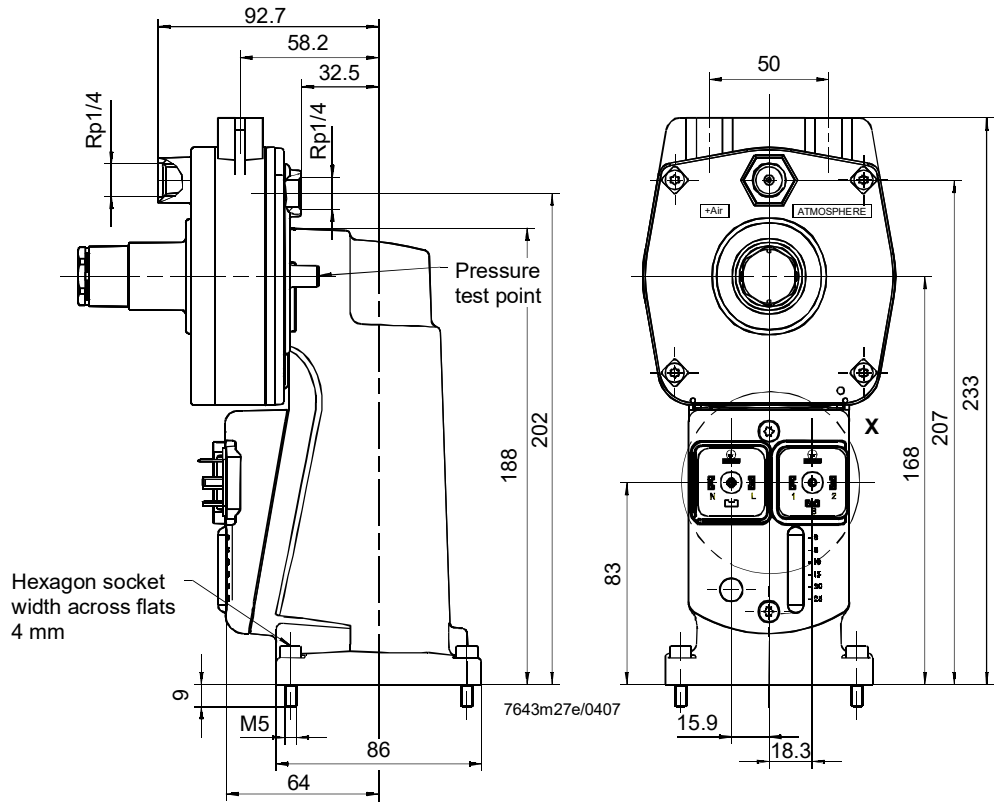

**SKP55.001**

Connector valve-actuator to EN 175301-803 design A, 2 pole + ⊕

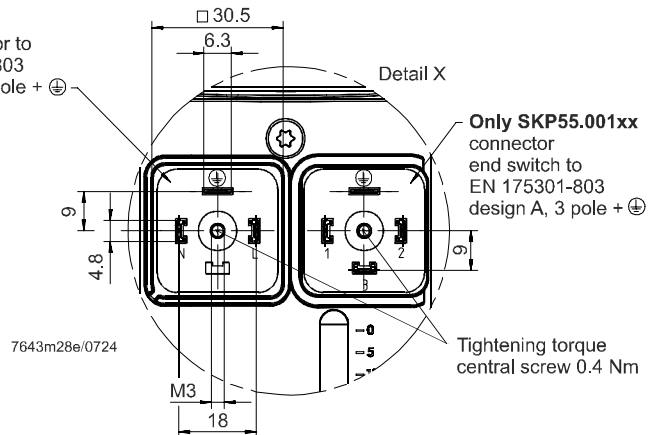

Dimensions in mm

**SKP75**

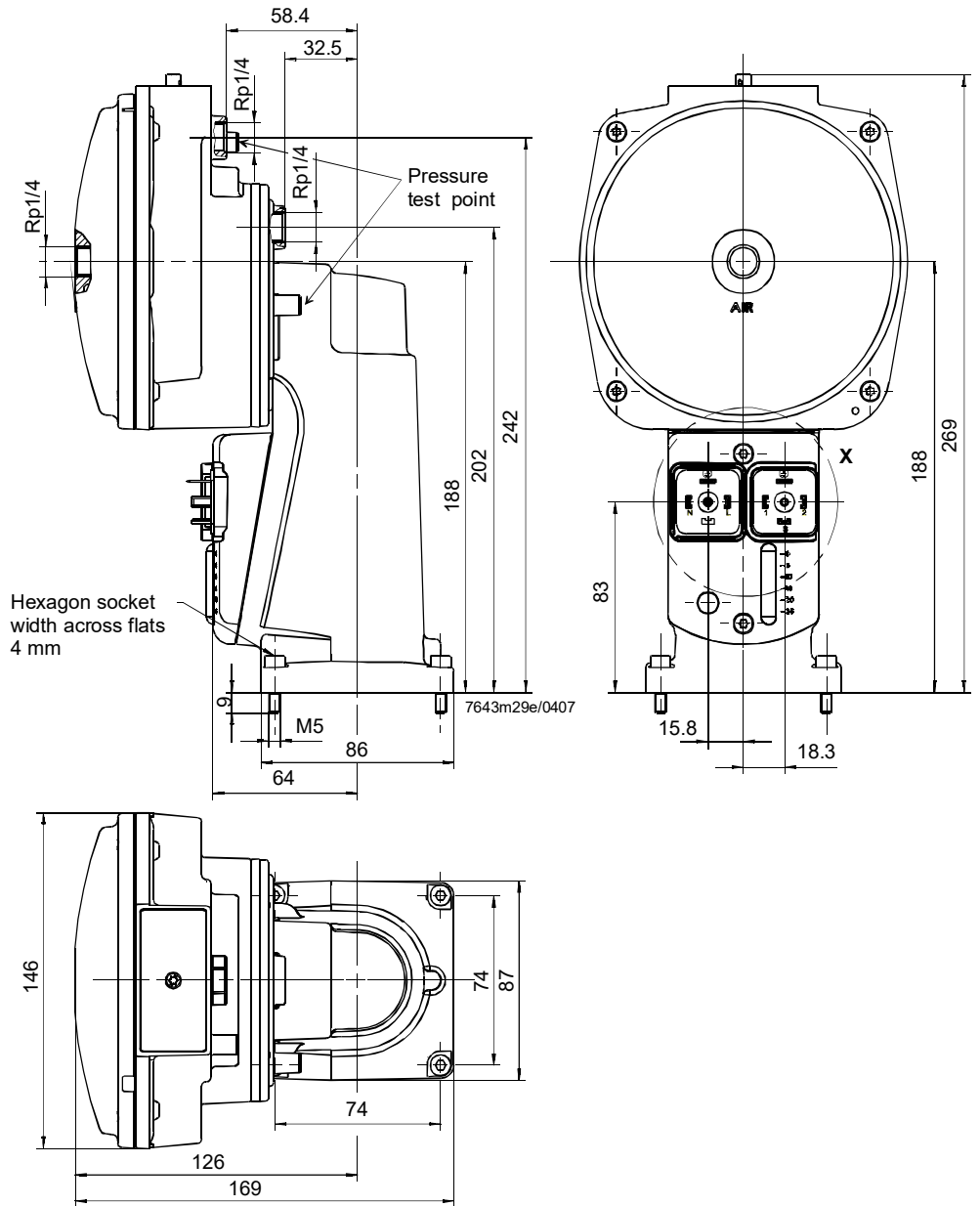

**SKP75.001**

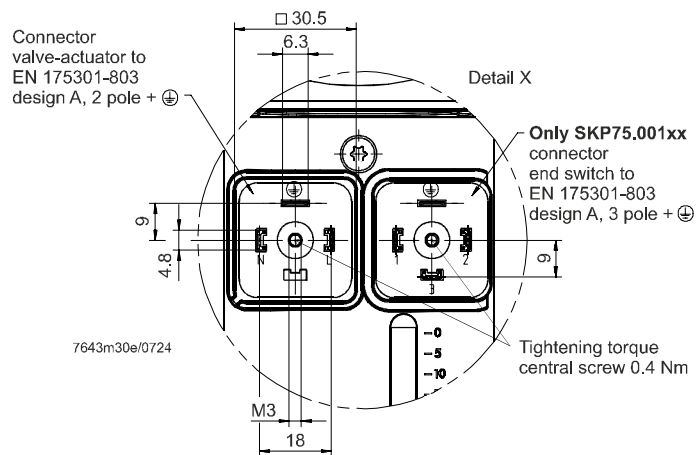

**Dimensions (cont'd)**

Dimensions in mm

Adapter plug  
**AGA62.000A000**

For mounting two SKPx5s on a VGx/VRx.

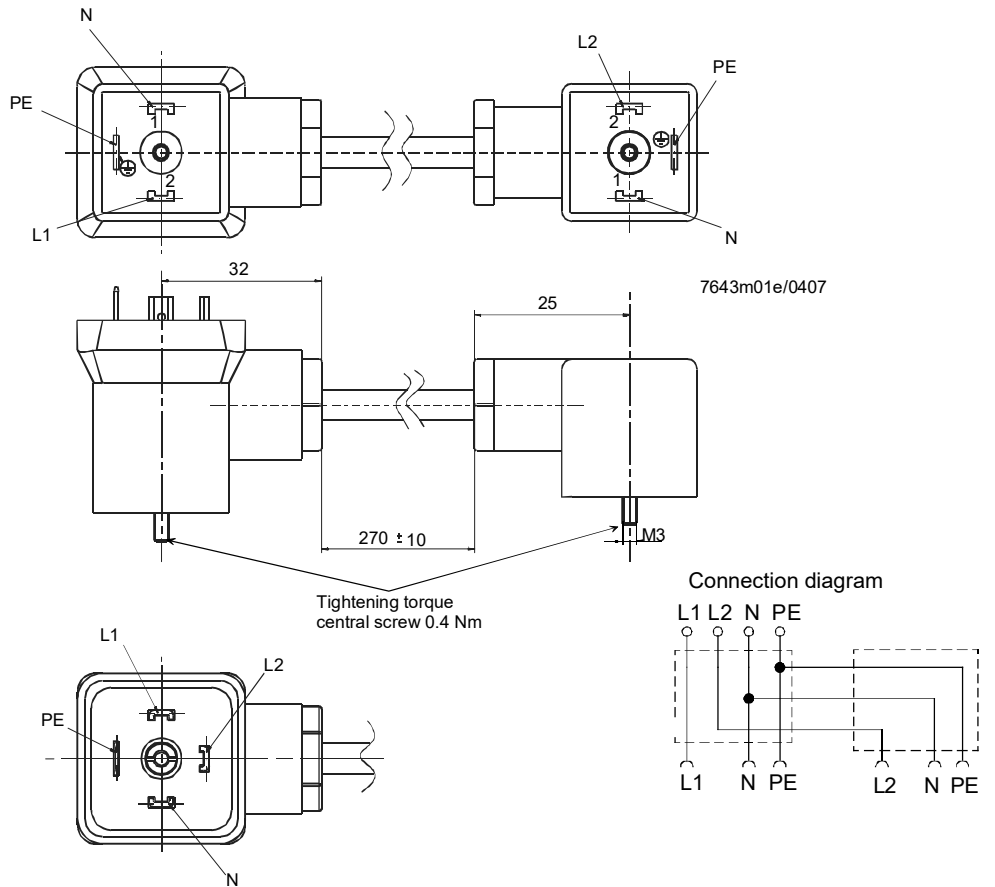

**AGA30.x**

