

| Part Name | 5425-2 | 5425-3 | 5425-4 | 5425-5 | 5425-6 | 5425-7-A | 5425-7-B | 5425-8-A |
|--|--|-----------|-----------|-----------|-----------|-----------|-----------|-----------|
| Mounting and Tile Assemblies Standard | for Burner Complete w/9" Tile | | | | | | | |
| Mounting and Tile Assembly † | 3-6668-1 | 3-6668-1 | 3-6668-1 | 3-6668-1 | 3-6668-1 | 3-6668-2 | 3-6668-2 | 3-6668-2 |
| LC Series | for Burner Complete w/9" Tile and Steel Jacket | | | | | | | |
| Mounting and Tile Assembly † | 3-6668-3 | 3-6668-3 | 3-6668-3 | 3-6668-3 | 3-6668-3 | 3-6668-4 | 3-6668-4 | 3-6668-4 |
| Tile and Jacket Assembly ‡ | 4-21583-1 | 4-21583-1 | 4-21583-1 | 4-21583-1 | 4-21583-1 | 4-21583-2 | 4-21583-2 | 4-21583-2 |
| Jacket | 4-5377-3 | 4-5377-3 | 4-5377-3 | 4-5377-3 | 4-5377-3 | 4-5378-3 | 4-5378-3 | 4-5378-3 |
| L4 Series | for Burner Complete w/9" Tile and 304 SST Jacket | | | | | | | |
| Mounting and Tile Assembly † | 3-6668-5 | 3-6668-5 | 3-6668-5 | 3-6668-5 | 3-6668-5 | 3-6668-6 | 3-6668-6 | 3-6668-6 |
| Tile and Jacket Assembly ‡ | 4-21583-3 | 4-21583-3 | 4-21583-3 | 4-21583-3 | 4-21583-3 | 4-21583-4 | 4-21583-4 | 4-21583-4 |
| Jacket | 4-5377-4 | 4-5377-4 | 4-5377-4 | 4-5377-4 | 4-5377-4 | 4-5378-4 | 4-5378-4 | 4-5378-4 |
| L9 Series | for Burner Complete w/9" Tile and 309 SST Jacket | | | | | | | |
| Mounting and Tile Assembly † | 3-6668-7 | 3-6668-7 | 3-6668-7 | 3-6668-7 | 3-6668-7 | 3-6668-8 | 3-6668-8 | 3-6668-8 |
| Tile and Jacket Assembly ‡ | 4-21583-5 | 4-21583-5 | 4-21583-5 | 4-21583-5 | 4-21583-5 | 4-21583-6 | 4-21583-6 | 4-21583-6 |
| Jacket | 4-5377-6 | 4-5377-6 | 4-5377-6 | 4-5377-6 | 4-5377-6 | 4-5378-5 | 4-5378-5 | 4-5378-5 |

- * Includes 3-3638-1 adapter.
- ◆ Extra cost option -- not part of standard burner assembly, and must be ordered separately.
- † Includes complete mounting, tile , jacket and retaining rods and nuts.
- ‡ Includes tile and jacket only.

WARNING: Situations dangerous to personnel and property may exist with the operation and maintenance of any combustion equipment. The presence of fuels, oxidants, hot and cold combustion products, hot surfaces, electrical power in control and ignition circuits, etc., are inherent with any combustion application. Components in combustion systems may exceed 160°F (71°C) surface temperatures and present hot surface contact hazard. Fives North American Combustion, Inc. suggests the use of combustion systems that are in compliance with all Safety Codes, Standards, Regulations and Directives; and care in operation.

CONTACT
fna.sales@fivesgroup.com
T +1 800 626 3477 - F +1 216 373 4237

Fives North American Combustion, Inc.
4455 East 71st Street - Cleveland, OH 44105 - USA
www.fivesgroup.com



fives
Industry can do it

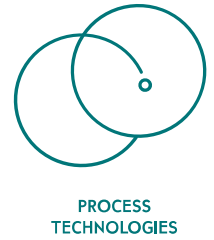

North American Fire•All™ Oil Burners

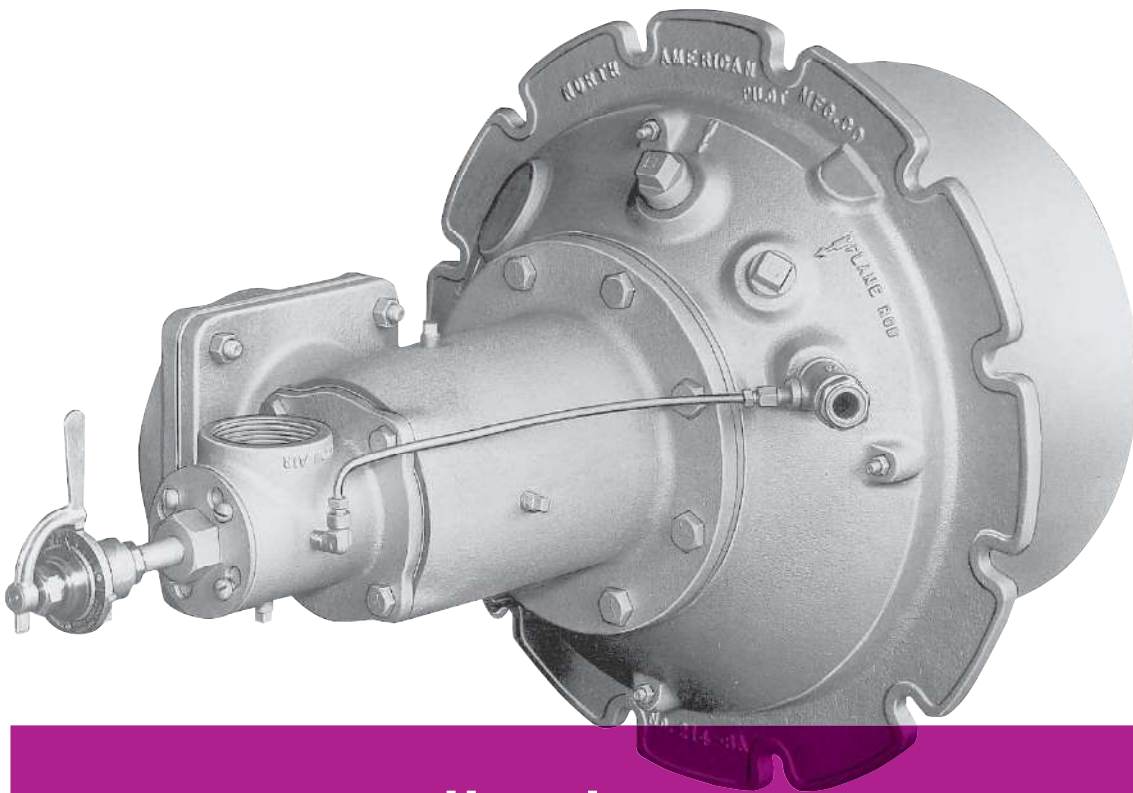

5514 Fire•All Oil Burners

- Oil-only Burner (light or heavy grade oil)
- Conventional forward flame pattern
- 1.8 to 30 million Btu/h HHV
- Chambers up to 2400°F (with alloy nose)
- Includes low pressure fuel oil atomizer

Product Overview | 5514 Oil Burners

5514 FIRE•ALL Oil Burners are rugged, maintenance-free, sealed-in burners for burning light or heavy oil on a wide variety of applications. Capable of efficient operation throughout a wide temperature range, they are equally at home on low temperature ovens and high temperature forge and melt furnaces.

Sealed mountings help maintain furnace pressure, controlled atmosphere, and closer fuel/air ratio control--all contributing to better product quality.

Fire•All Burners are a proven workhorse on all types of furnaces.

Burners can be turned down to atomizing air only, but stability limits vary depending on burner size, grade of oil, and furnace environment--please consult North American regarding minimum oil rates for your specific application.

Oil viscosity at the burners must not exceed 100 SSU; Oil pressure at the Ratiotrol™ should be between 25 and 30 psi. Oil pressure at rated capacity is 10 to 15 psi at Sensitrol™ and less than 2 psi at burner. Minimum atomizing air pressure at the burner is 14 psi for light oil, 22 psi for heavy oil.

COMBUSTION CHARACTERISTICS

5514 Burners are stable with 200% or more excess air. They may also be operated with excess fuel without forming carbon if additional combustion air is available in the furnace near the burner. Excess fuel limit with heavy oil is 50% as atomization deteriorates at richer ratios.

**Total air capacities
(including main and atomizing air)**

| flame lengths Burner designation | 16 psi air pressure drop across the burner | | | 24 psi air pressure drop across the burner | | | Approx. with 16 psi main air (in open furnace) |
|--|---|-------------------------------|-------------------------------|---|------------------|------------------|--|
| | Air ^① scfh | Light Oil ^② gph | Heavy Oil ^③ gph | Air scfh | Light Oil gph | Heavy Oil gph | |
| 5514-6 | 17 900 | 13 | 12 | 21 900 | 16 | 15 | 5' |
| 5514-7 | 28 400 | 21 | 19 | 34 800 | 26 | 23 | 5' - 6' |
| 5514-8-A | 48 900 | 36 | 33 | 60 000 | 44 | 40 | 8' - 9' |
| 5514-8-B | 81 500 | 60 | 54 | 100 000 | 74 | 67 | 9' - 12' |
| 5514-9 | 165 000 | 122 | 110 | 202 000 | 150 | 135 | 15' - 18' |
| 5514-10 | 247 000 | 183 | 165 | 303 000 | 224 | 202 | 20' |

① For Btu/hr, multiply by 100

② Light oil at 135 000 Btu/gal.

③ Heavy oil at 150 000 Btu/gal.

| Burner designation | Main air capacities in scfh | | | | | | Atomizing air capacities in scfh | | | | | |
|-----------------------|--|---------|---------|---------|---------|---------|--|--------|--------|--------|--------|--------|
| | Air pressure drop across the burner in psi | | | | | | Air pressure drop across the burner in psi | | | | | |
| | 1 | 5 | 6 | 8 | 12 | 16 | 14 | 16 | 18 | 20 | 22 | 24 |
| 5514-6 | 3 710 | 8 300 | 9 100 | 10 500 | 12 900 | 14 900 | 2 800 | 3 000 | 3 180 | 3 360 | 3 510 | 3 660 |
| 5514-7 | 6 100 | 13 600 | 15 000 | 17 200 | 21 000 | 24 400 | 3 770 | 4 030 | 4 270 | 4 500 | 4 720 | 4 900 |
| 5514-8-A | 10 600 | 23 700 | 26 000 | 30 000 | 36 700 | 42 400 | 6 050 | 6 500 | 7 000 | 7 300 | 7 600 | 7 850 |
| 5514-8-B | 17 600 | 39 200 | 43 000 | 49 600 | 60 500 | 70 000 | 10 600 | 11 300 | 12 000 | 12 700 | 13 200 | 13 800 |
| 5514-9 | 36 600 | 82 000 | 89 500 | 104 000 | 127 000 | 146 000 | 17 200 | 18 400 | 19 600 | 20 700 | 21 600 | 22 500 |
| 5514-10 | 54 500 | 122 000 | 135 000 | 154 000 | 189 000 | 218 000 | 27 200 | 29 100 | 30 900 | 32 600 | 34 100 | 35 500 |

Tile | 5514 Oil Burners

Flame Supervision. An ultraviolet cell† will monitor pilot or main flame on gas or oil. For maximum safety, North American urges **interrupted** pilots when flame safeguards are used--pilots should be on only for a preset ignition period (usually 15 seconds), after which flame supervision detects main fire only. Adapters for mounting flame detection devices on 5514 Burners are tabulated on Bulletin 8832.

Tile/Installation. Burner tiles are cast refractory rated for 2800°F furnace temperature. They should be supported securely in the furnace wall by a layer of castable refractory (not insulation) at least 9" thick all around the tile, extending back to the furnace shell and securely anchored to it. (See Supplement DF-M1.)

Tiles are replaceable in the field except for the 5514-10, whose mounting must be returned to the factory for tile replacement (or purchase a spare mounting plate with a tile cast onto it).

Complete burners include tile, mounting plate, and an observation port into which a small quantity of atomizing air is introduced to keep the glass clear. Order Sensitrol™ Oil Valve and pilot tips separately. See 5514 Dimension Sheet for recommended Sensitrol™ oil valve and premix pilot tip.

Jacketed Tile options are available for applications where the tile is not supported by furnace refractory. Jackets are available in three different metals and have maximum temperature ratings for each. They must be protected with sufficient insulation so as not to exceed rated temperature. The maximum temperature rating for jacket metals depends upon frequency of heat-up/cool-down cycles. As an example, batch annealing furnaces that are heated and cooled every day should use the "intermittent exposure" ratings. Continuous annealing furnaces that remain at the same temperature for months at a time, can use the higher "continuous" rating.

| Designation | Jacket Metal | Continuous max. temp. | Intermittent exposure |
|-------------|---------------|-----------------------|-----------------------|
| 5514- -LC | carbon steel | 700°F | 700°F |
| 5514- -L4 | 304 stainless | 1600°F | 1500°F |
| 5514- -L9 | 309 stainless | 1900°F | 1800°F |

† Cleaning air must be introduced into the port downstream of the sensor to keep oil and poc's off the lens.

Burner Nose options are available for sizes shown below and can be specified in the product number. The burner nose establishes main combustion air flow and influences flame propagation. Nose material is either cast iron that is suitable for cold air applications up to 1800°F, or cast stainless alloy for preheated air (maximum 700°F) applications up to 2400 2°F.

| Mat'l | Cap'y | -6 | -7 | -8A | -8B | -9 | -10 |
|------------|-------|----|----|-----|-----|----|-----|
| Cast iron | 1.0 | √ | √ | √ | √ | √ | √ |
| Cast Alloy | 1.0 | √ | √ | √ | √ | √ | √ |
| Cast iron | 1.1 | | √ | √ | √ | √ | √ |
| Cast Alloy | 1.1 | | √ | √ | √ | √ | √ |
| Cast iron | 1.2 | | | √ | √ | √ | √ |
| Cast Alloy | 1.2 | | | √ | √ | √ | √ |
| Cast iron | 1.3 | | | √ | √ | √ | √ |
| Cast Alloy | 1.3 | | | √ | √ | √ | √ |

The product designation 1.0 represents standard main air capacity shown on page 1. Use of an extra capacity burner nose will result in either more air at 16 psi or standard air flow at lower pressure. Extending the capacity of the burner by increasing air pressure beyond 16 psi, or using the extra capacity nose, is acceptable for light oil applications. Specific applications involving heavy oil and extra capacity should be reviewed with North American.

Also, when firing extra capacity, the combustion air flow velocity within the supply piping, and associated pressure loss, can be excessive for some burners. The -8B, -9 and -10 products when operated at 1.2 or 1.3 capacity will develop high pipe velocity based on the burner's air connection size. As an alternative to increasing blower pressure, an oversized air inlet can be purchased separately for these size burners. The connections are SW-type (slip-on sleeve or welded construction) and are one pipe size larger than the standard supply. Nose and oversize air connection part numbers can be found in supplement literature (see Parts List and Burner Options documents).

Additional options are available for the 5514 burner but require consultation with North American for application and ordering information. See Sheet 6514-3 for an overview of burner options.

Dimensions | 5514 Oil Burners

CLEARANCE DIMENSIONS

(for details, see Dimensions 5514)

| Burner designation | Dimensions in inches | | | | | | | | Wt. lbs. |
|--------------------|----------------------|----|---|-----|-----|-----|-----|-----|----------|
| | A | B | C | D | E | F | G | H | |
| 5514-6 | 3 | 1½ | ¾ | 19½ | 15½ | 9 | 15 | 10¾ | 190 |
| 5514-7 | 4 | 2 | ¾ | 20½ | 16¾ | 8¾ | 16 | 11¾ | 215 |
| 5514-8-A | 6 | 2½ | ¾ | 22¾ | 22¾ | 10 | 17¾ | 12¾ | 320 |
| 5514-8-B | 6 | 3 | ¾ | 24 | 23¼ | 12¾ | 19 | 13½ | 410 |
| 5514-9 | 8 | 4 | ½ | 28 | 29½ | 13¾ | 23 | 16 | 735 |
| 5514-10 | 10 | 6 | ½ | 32½ | 33¾ | 13¾ | 27½ | 20½ | 950 |

*SW connection standard for -9 and -10 only.

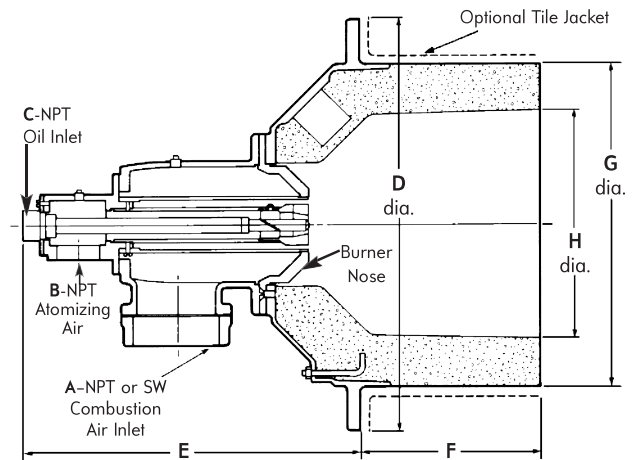

DIMENSIONS SHOWN ARE SUBJECT TO CHANGE. PLEASE OBTAIN CERTIFIED PRINTS FROM FIVES NORTH AMERICAN COMBUSTION, INC. IF SPACE LIMITATIONS OR OTHER CONSIDERATIONS MAKE EXACT DIMENSION(S) CRITICAL.

ORDERING INFORMATION

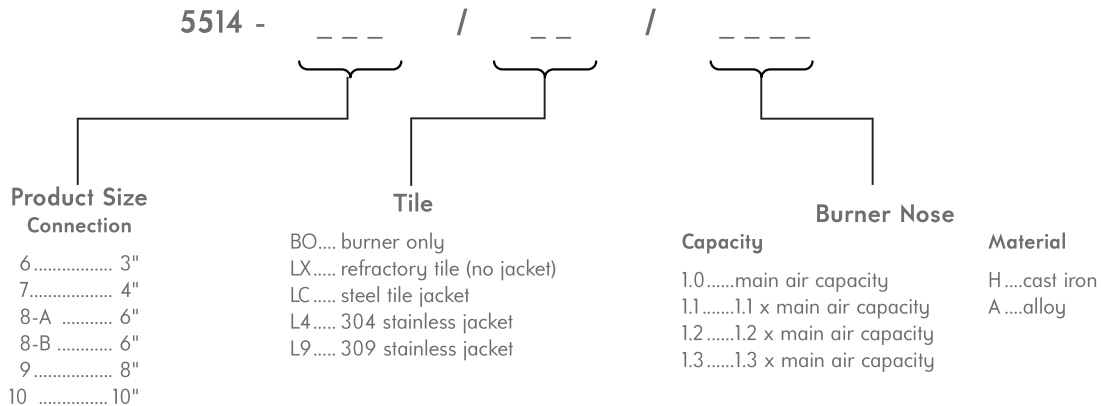

Example 1 5514-8-A/LC/1.2A Fireall oil burner complete with carbon steel jacketed tile and 1.2 capacity alloy nose

Example 2 5514-6/BO/1.0H Fireall oil burner only with standard capacity iron nose

Example 3 5514-9/LX/1.2H Fireall oil burner complete with refractory tile and 1.2 capacity iron nose

Note: See Supplement 6514-6 for cross referencing old product numbers.

WARNING: Situations dangerous to personnel and property may exist with the operation and maintenance of any combustion equipment. The presence of fuels, oxidants, hot and cold combustion products, hot surfaces, electrical power in control and ignition circuits, etc., are inherent with any combustion application. Components in combustion systems may exceed 160°F (71°C) surface temperatures and present hot surface contact hazard. Fives North American Combustion, Inc. suggests the use of combustion systems that are in compliance with all Safety Codes, Standards, Regulations and Directives; and care in operation.

CONTACT

fna.sales@fivesgroup.com

T +1 800 626 3477 - F +1 216 373 4237

Fives North American Combustion, Inc.
4455 East 71st Street - Cleveland, OH 44105 - USA
www.fivesgroup.com



fives
Industry can do it



fives

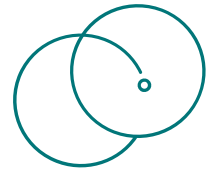

PROCESS TECHNOLOGIES

ENERGY | COMBUSTION

North American Fire•All™ Oil Burners

Dimensions 5514

DIMENSIONS - Main air, atomizing air, and oil connections can be rotated relative to one another and to the mounting plate. Drawings show connections as assembled at the factory. These arrangements reduce maintenance by preventing oil dripping into air manifolds (which should be above burners) and by minimizing dirt accumulation in pilots and flame supervisory devices. Pilot and main air connections cannot be aligned in the same direction.

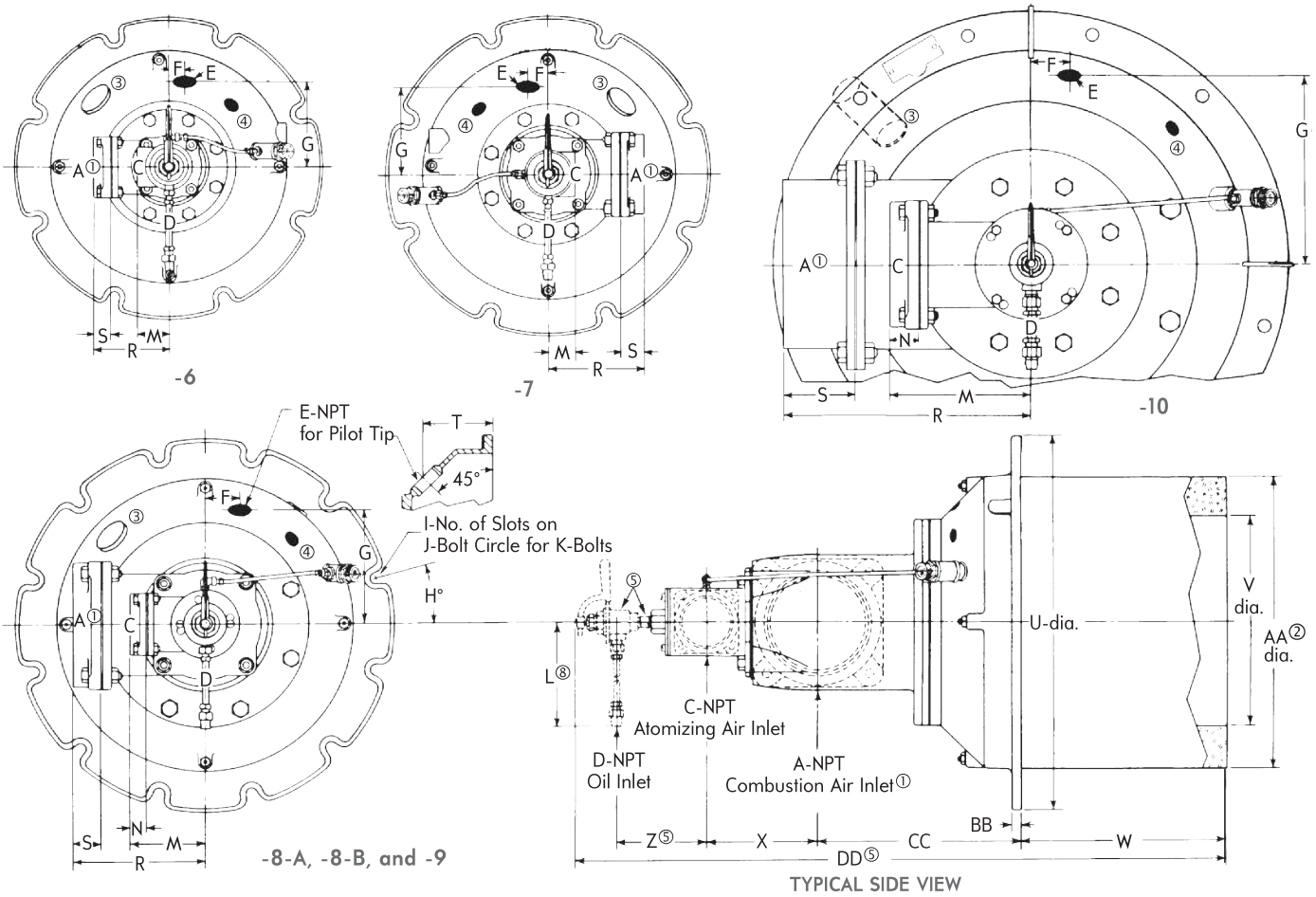

DIMENSIONS SHOWN ARE SUBJECT TO CHANGE. PLEASE OBTAIN CERTIFIED PRINTS FROM FIVES NORTH AMERICAN COMBUSTION, INC. IF SPACE LIMITATIONS OR OTHER CONSIDERATIONS MAKE EXACT DIMENSION(S) CRITICAL.

| Burner designation | dimensions in inches and degrees | | | | | | | | | | | | | |
|--------------------|----------------------------------|----------------|---|----|----|---------------------------------|----------------|----|-----|---|----------------|-----------------|----|-----|
| | A ^① | C | D | E | F | G | H [°] | I | J | K | L ^⑧ | M | N | R |
| 5514-6 | 3 | 1½ | ¾ | ¾ | 1 | 5 ¹⁷ / ₃₂ | 22½ | 8 | 18 | ⅝ | 19¾ | 2 | — | 5¾ |
| 5514-7 | 4 | 2 | ¾ | 1¼ | 1¼ | 5¾ | 22½ | 8 | 19 | ⅝ | 19¾ | 1¾ | — | 6½ |
| 5514-8-A | 6 | 2½ | ¾ | 1¼ | 1½ | 6⅞ | 15 | 12 | 21¼ | ⅝ | 19¾ | 2¾ | — | 7¾ |
| 5514-8-B | 6 | 3 ^⑦ | ¾ | 1¼ | 2¼ | 7¾ | 15 | 12 | 22½ | ⅝ | 19¾ | 5¾ ^① | 1⅞ | 8½ |
| 5514-9 | 8 | 4 ^⑦ | ½ | 1½ | 2¼ | 9⅞ | 15 | 12 | 26½ | ⅝ | 20¾ | 7⅞ ^① | 1⅞ | 13¾ |
| 5514-10 | 10 | 6 ^⑦ | ½ | 1½ | 2½ | 12¾ | 15 | 12 | 30½ | ¾ | 20¾ | 8⅞ ^① | 1¾ | 15¾ |

| Burner designation | dimensions in inches | | | | | | | | 5514- /LX (refractory tile) | | | | |
|--------------------|-----------------------------|----|----|-----|-----|-----|-----|----------------|-----------------------------|----|-----|-----------------|-------|
| | R ₁ ^⑥ | S | T | U | V | W | X | Z ^⑤ | AA ^② | BB | CC | DD ^⑤ | wt-lb |
| 5514-6 | 10¾ | 1⅞ | 3⅞ | 19½ | 10¾ | 9 | 4⅞ | 4⅞ | 15 | ⅝ | 8¼ | 28⅞ | 190 |
| 5514-7 | 10⅞ | 1⅞ | 3⅞ | 20½ | 11¾ | 8⅞ | 4⅞ | 4⅞ | 16 | ⅝ | 9¼ | 30⅞ | 215 |
| 5514-8-A | 11¼ | 1⅞ | 4⅞ | 22¾ | 12¾ | 10 | 6¼ | 4⅞ | 17¾ | ⅝ | 12⅞ | 36⅞ | 320 |
| 5514-8-B | 12¾ | 1⅞ | 4⅞ | 24 | 13½ | 12⅞ | 6⅞ | 5⅞ | 19 | ⅝ | 12⅞ | 40⅞ | 410 |
| 5514-9 | — | 3⅞ | 6⅞ | 28 | 16 | 13⅞ | 11¼ | 6⅞ | 23 | ⅝ | 14⅞ | 48⅞ | 735 |
| 5514-10 | — | 4⅞ | 5⅞ | 32½ | 20½ | 13¾ | 12⅞ | 6⅞ | 27½ | ½ | 16⅞ | 52¼ | 950 |

See page 2 for notes and additional information.

| Burner designation | 5514- /LC, L4, L9 (jacketed tile) | | | | | All 5514 | |
|--------------------|-----------------------------------|--------|----------|-----------------|-------|----------------------|-----------------------|
| | dimensions in inches | | | | | Sensitrol™ oil valve | Recommended pilot tip |
| | AA ^② | BB | CC | DD ^⑤ | wt-lb | | |
| 5514-6 | 16 | 3/4 | 8 3/8 | 28 7/16 | 210 | 1813-02-C | 4021-12 |
| 5514-7 | 17 | 3/4 | 9 3/8 | 30 1/4 | 240 | 1813-02-D | 4025-0-T |
| 5514-8-A | 18 3/4 | 3/4 | 12 15/16 | 36 13/16 | 355 | 1813-02-D | 4025-0-T |
| 5514-8-B | 20 | 3/4 | 12 15/16 | 40 11/16 | 455 | 1813-02-D | 4025-0-T |
| 5514-9 | 24 1/4 | 1 3/16 | 14 7/8 | 48 9/16 | 800 | 1813-01 | 4025-2-T |
| 5514-10 | 27 1/2 | 1 1/16 | 16 5/16 | 52 1/4 | 1000 | 1813-01 | 4025-2-T |

- ① A square threaded flange is used for sizes -6, -7, -8. SW style (suitable for slip-on or welded connection) inlet may be ordered as a special option. An SW inlet is standard for -9 and -10 burners.
- ② Opening in furnace shell or outer wall must be 1/2" larger than dimension "AA" to allow for mounting plate fillet and draft.
- ③ Blank boss - This may be ordered as a special option with a 1 1/2" tap suitable for 5025-1-3T Oil Pilot, in which case North American will drill out 1/2" web of refractory left in tile before shipment, and the burner nose will be positioned so none of its holes are in front of that opening. For -10 size, an appropriate 1 1/2" npt half-coupling will be added as a special option.
- ④ 1" fpt for electrode or UV flame detector.
- ⑤ Optional (recommended) Sensitrol™ Oil Valve and pipe nipple are not included as part of the burner assembly, and must be ordered separately. Dimensions Z and DD assume a 3/8" close nipple between burner and Sensitrol Oil Valve (5514-6 through -8-B) and a 1/2" close nipple between burner and Sensitrol Valve (5514-9 and -10).
- ⑥ Applies when optional SW inlet is specified.
- ⑦ Flanged connection--a standard North American square threaded flange is used.
- ⑧ Optional 8773 flex tubing purchased separately from North American.

ANSI or SW flanges: Flat face companion flanges and full face gaskets are supplied with this equipment. Do not use raised face flanges that may damage mating flange.

ORDERING INFORMATION

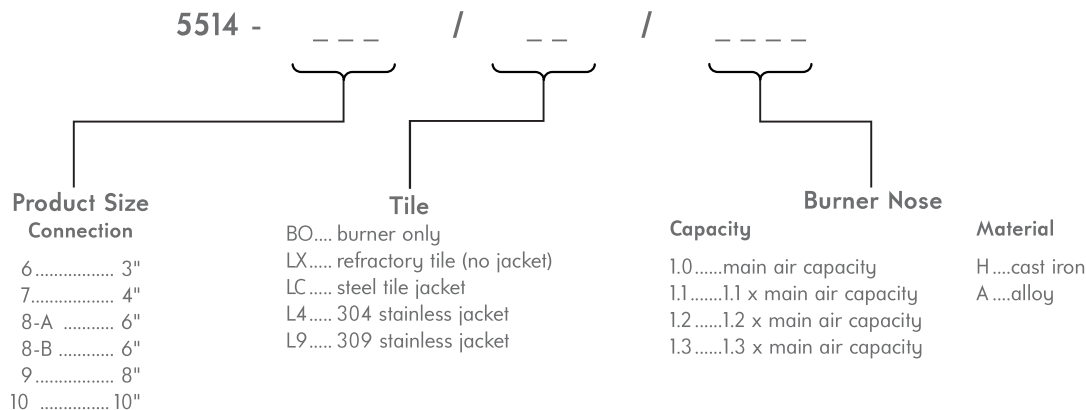

- Example 1 5514-8-A/LC/1.2A Fireall oil burner complete with carbon steel jacketed tile and 1.2 capacity alloy nose
- Example 2 5514-6/BO/1.0H Fireall oil burner only with standard capacity iron nose
- Example 3 5514-9/LX/1.2H Fireall oil burner complete with refractory tile and 1.2 capacity iron nose

Note: See Supplement 6514-6 for cross referencing old product numbers.

WARNING: Situations dangerous to personnel and property may exist with the operation and maintenance of any combustion equipment. The presence of fuels, oxidants, hot and cold combustion products, hot surfaces, electrical power in control and ignition circuits, etc., are inherent with any combustion application. Components in combustion systems may exceed 160°F (71°C) surface temperatures and present hot surface contact hazard. Fives North American Combustion, Inc. suggests the use of combustion systems that are in compliance with all Safety Codes, Standards, Regulations and Directives; and care in operation.

CONTACT

fna.sales@fivesgroup.com
T +1 800 626 3477 - F +1 216 373 4237

Fives North American Combustion, Inc.
4455 East 71st Street - Cleveland, OH 44105 - USA
www.fivesgroup.com



fives
Industry can do it

North American Fire•All™ Oil Burners

Parts List 5514-1

Parts for 5514 Oil Burners Sizes -6, -7, -8-A, -8-B, and -9 inclusive

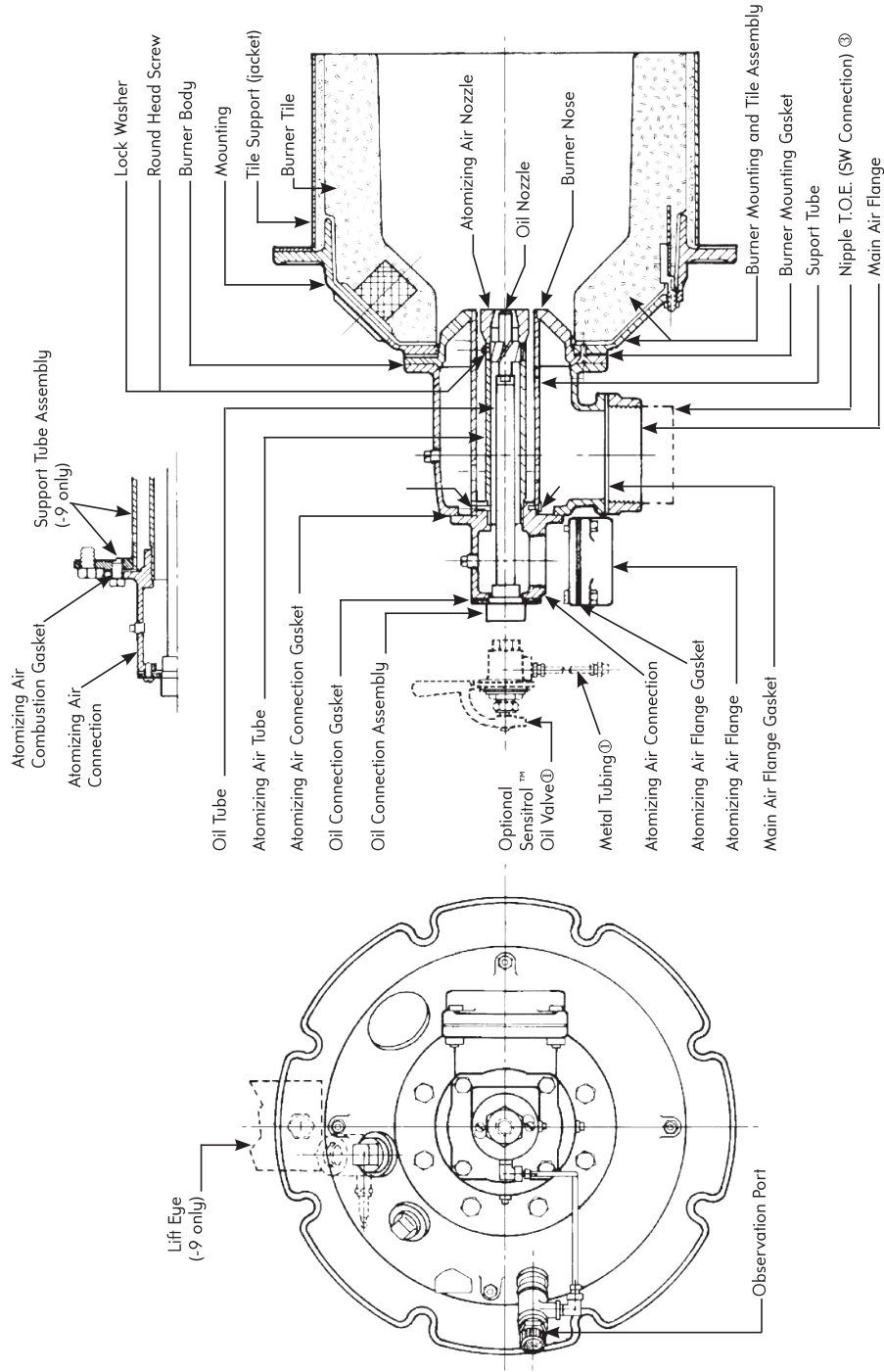

WARNING: Situations dangerous to personnel and property may exist with the operation and maintenance of any combustion equipment. The presence of fuels, oxidants, hot and cold combustion products, hot surfaces, electrical power in control and ignition circuits, etc., are inherent with any combustion application. Components in combustion systems may exceed 160°F (71°C) surface temperatures and present hot surface contact hazard. Fives North American Combustion, Inc. suggests the use of combustion systems that are in compliance with all Safety Codes, Standards, Regulations and Directives; and care in operation.

| Part Name | Burner Designation | | | | |
|---------------------------------------|--------------------|-------------|-------------|-------------|-------------|
| | 5514-6 | 55147 | 5514-8-A | 5514-8-B | 5514-9 |
| Atomizing Air Connection | 3-4839-1 | 3-4845-1 | 3-4854-1 | 3-4874-1 | 3-2847-2 |
| Atomizing Air Conn. Gasket | 4-6742-1 | 3-2517-1 | 4-6754-1 | 4-6765-1 | 3-2625-2 |
| Atomizing Air Flange | — | — | — | 2-2310-14 | 22310-7 |
| Atomizing Air Flange Gasket | — | — | — | 4-5371-2 | 4-5371-3 |
| Atomizing Air Nozzle | 3-2677-1 | 3-2514-1 | 32992-1 | 34688-1 | 3-2611-1 |
| Atomizing Air Tube | 3-2890-2 | 3-2896-2 | 3-3020-2 | 3-2903-3 | 3-2970-2 |
| Burner Body | 3-2688-2 | 3-2422-2 | 3-2999-2 | 3-2646-2 | 3-2845-3 |
| Burner Mounting Gasket | 3-2683-2 | 3-2532-2 | 3-3004-2 | 3-2653-2 | 3-2631-3 |
| Burner Tile, Cast | 3-7094-1 | 3-7095-1 | 3-0796-1 | 3-7097-1 | 3-7098-1 |
| Burner Mtg. and Tile | 3-7099-1 | 3-7099-4 | 3-7099-7 | 3-7099-10 | 3-7099-13 |
| Grove Pin (2 req'd) | R570-26300 | R5750-2300 | R570-2300 | R570-2330 | R570-2310 |
| Lift Eye | — | — | — | — | 3-2780-1 |
| Lock Washer (2 req'd) | R970-3180-S | R970-3180-S | R970-3180-S | R970-3180-S | R970-3180-S |
| Main Air Flange Standard | 8765-6-C | 8765-7-D | 6765-8-E | 8765-8-E | 8765-9-FWⓈ |
| Main Air T.O.E Ⓢ (SW Conn.) | R590-7057 | R590-7154 | R590-7170 | R590-7170 | — |
| (Oversize SW Conn.) | — | — | — | 3-21995-1 | 3-21996-1 |
| Main Air Flange Gasket | 4-5371-2 | 4-5371-3 | 4-5371-4 | 4-5371-4 | 4-5371-5 |
| Metal Tubing Ⓢ | 3-0310-7 | 3-0310-7 | 3-0310-7 | 3-0310-7 | 3-0310-8 |
| Mounting Standard | 3-2684-5 | 3-2528-4 | 3-2998-3 | 3-2645-3 | 3-2630-4 |
| Mounting 1½" Tap | 3-2684-6 | 3-2528-5 | 3-2998-4 | 3-2645-4 | 3-2630-5 |
| Mounting 2" Tap | 3-2684-7 | 3-2528-6 | 3-2998-5 | 3-2645-5 | 3-2630-6 |
| Nose, 1.0 Cast Iron | 3-3201-4 | 3-3203-4 | 3-3202-1 | 3-3200-1 | 3-3204-1 |
| Nose, 1.0 Cast Alloy | 3-3201-5 | 3-3203-5 | 3-3202-2 | 3-3200-2 | 3-3204-2 |
| Nose, 1.1 Cast Iron | — | 3-3203-8 | 3-3202-3 | 3-3200-3 | 3-3204-3 |
| Nose, 1.1 Cast Alloy | — | 3-3203-9 | 3-3202-4 | 3-3200-4 | 3-3204-4 |
| Nose, 1.2 Cast Iron | — | — | 3-3202-5 | 3-3200-5 | 3-3204-5 |
| Nose, 1.2 Cast Alloy | — | — | 3-3202-6 | 3-3200-6 | 3-3204-6 |
| Nose, 1.3 Cast Iron | — | — | 3-3202-7 | 3-3200-7 | 3-3204-7 |
| Nose, 1.3 Cast Alloy | — | — | 3-3202-8 | 3-3200-8 | 3-3204-8 |
| Observation Port | 8790-0 | 8790-0 | 8790-0 | 8790-0 | 8790-0 |
| Oil Connection Assembly | 3-2682-2 | 3-2519-2 | 3-2997-1 | 3-2651-2 | 3-2627-2 |
| Oil Connection Gasket | — | — | 3-3000-1 | 3-2656-2 | 3-2624-2 |
| Oil Nozzle Assembly | 3-2676-1 | 3-2513-1 | 3-3003-1 | 3-2674-1 | 3-2670-1 |
| Oil Tube | 3-2891-1 | 3-2895-1 | 3-3019-1 | 3-2902-1 | 3-2972-1 |
| Round Head Screw (2 req'd) | R775-2510-S | R775-2510-S | R775-2510-S | R775-2510-S | R775-2510-S |
| Self-Tapping Pan Head Screw (2 req'd) | R777-0330-C | R777-0334-C | R777-0330-C | R777-0509 | — |
| Sensitrol™ Oil Valve Ⓢ | 1813-02-C | 1813-02-D | 1813-02-D | 1813-02-D | 1813-01 |
| Support Tube | 3-4840-1 | 3-4846-1 | 3-4855-1 | 3-4871-1 | 3-4923-1 |
| Tile Support Steel | 3-2691-1 | 3-2703-1 | 3-2991-1 | 3-2661-1 | 3-2632-2 |
| 304 Stainless Steel | 3-2691-2 | 3-2703-2 | 3-2991-2 | 3-2661-2 | 3-2632-3 |
| 309 Stainless Steel | 3-2691-3 | 3-2703-2 | 3-2991-3 | 3-2661-3 | 3-2632-4 |

Parts for 5514-10 Oil Burners

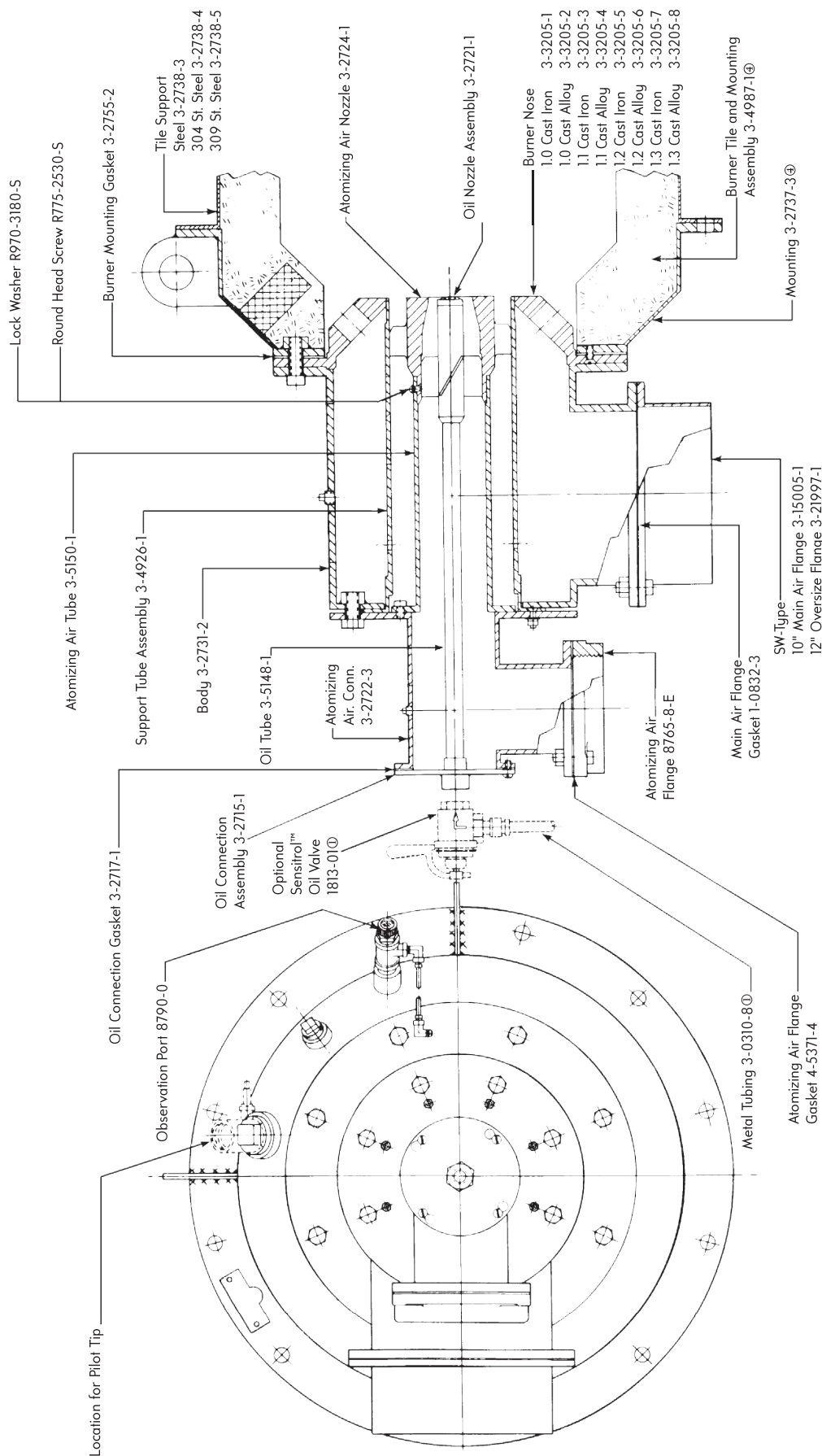

WARNING: Situations dangerous to personnel and property may exist with the operation and maintenance of any combustion equipment. The presence of fuels, oxidants, hot and cold combustion products, hot surfaces, electrical power in control and ignition circuits, etc., are inherent with any combustion application. Components in combustion systems may exceed 160°F (71°C) surface temperatures and present hot surface contact hazard. Fives North American Combustion, Inc. suggests the use of combustion systems that are in compliance with all Safety Codes, Standards, Regulations and Directives; and care in operation.

See page 4 for notes

6514 Dual-Fuel Conversion Kits for 5514 Oil Burners

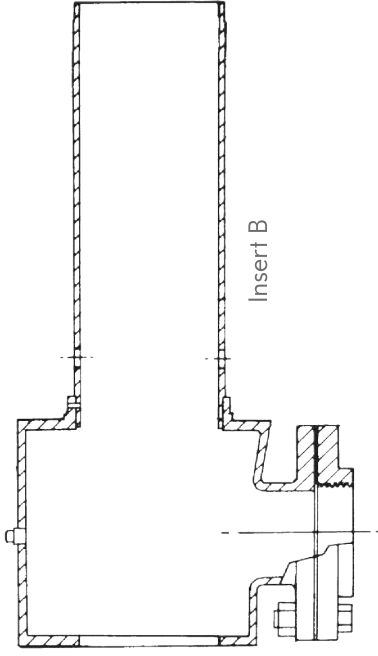
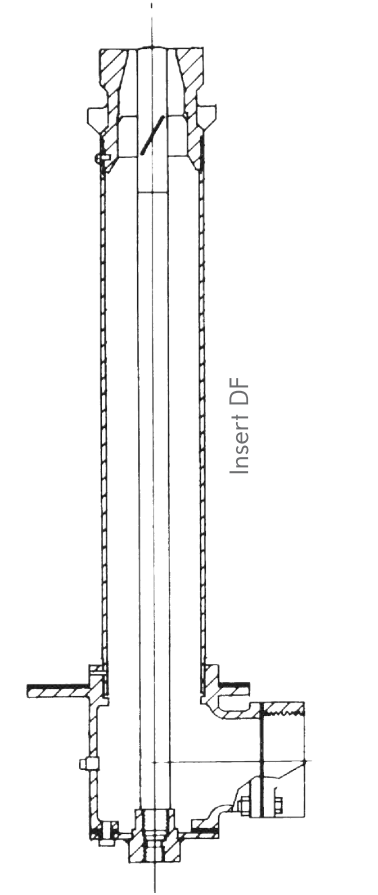

To order Oil-to-Dual-Fuel Kit, specify: 6514CK-(code for pipe size)-5514 Oil-to-Dual-Fuel Conversion Kit. Oil-to-Dual-Fuel Kit does not include Sensitrol™ Oil Valve. Optional (recommended) Sensitrol Oil Valve must be ordered separately.

Example: 6514CK-7-5514 Oil-to-Dual-Fuel Conversion Kit

[Kit consists of Inserts DF and B shown above, and does not include SOV, Insert DF consists of : Atomizing air connection (with inlet gland and gasket on -8-B, -9, and -10), D-F atomizing air tube, atomizing air nozzle, oil connection assembly, D-F oil tube, and standard multi-port oil nozzle. Insert B consists of: Gas inlet connection (with inlet flange and gasket on -8-B, -9, and -10), gas tube, studs and /or bolts and nuts. Existing oil burner parts to discard are: Atomizing air connection and support tube assembly (with inlet flange and gasket on -8-B, -9 and -10), atomizing air nozzle, oil connection assembly, oil tube, and standard multi-port oil nozzle.]

ORDER MUST SPECIFY: 1-Part Number 2-Part Name 3-Burner Designation
Examples: 8765-6-C Main Air Flange for 5514-6
3-5150-1 Atomizing Air Tube for 5514-10

NOTES

- ① Optional (recommended) Sensitrol Oil Valve and metal tubing are not part of standard burner assembly, and must be ordered separately.
- ② SW-Type Main Air Flange for 5514-9
- ③ Optional main air connection with SW and oversize air connection with SW are not part of standard burner assembly and must be ordered separately.
- ④ Spare tile is available only assembled to new mounting plate or to customer's mounting (returned to North American prepaid, FOB Cleveland, Ohio plant).

CONTACT

fna.sales@fivesgroup.com
 T +1 800 626 3477 - F +1 216 373 4237

Fives North American Combustion, Inc.
 4455 East 71st Street - Cleveland, OH 44105 - USA
www.fivesgroup.com

