

North American Low NOx Flat Flame™ Gas Burners Wall and Roof Mounting

Dimensions 4832

WALL TILE DESIGNS (FLANGELESS MOUNTING)

SQUARE TILES 4832- -SG and 4832D- -SG

DIMENSIONS inches

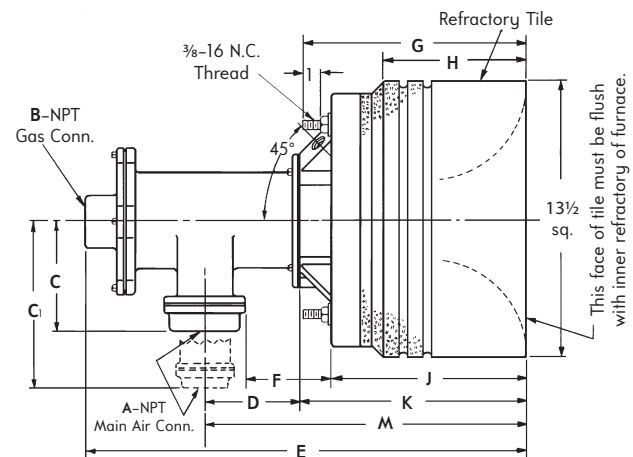
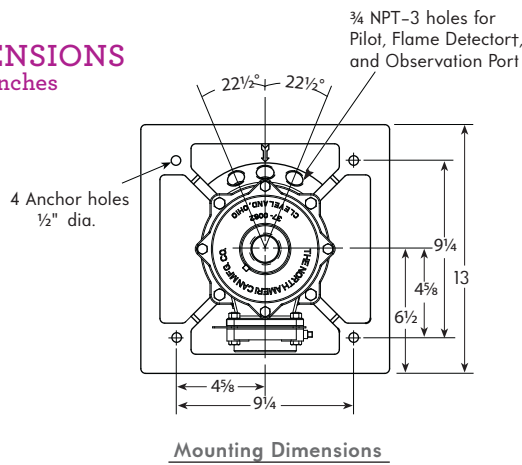

Standard 13 1/2" square tile shown. For dimensions of optional round or tapered tiles, see below or page 2.
All standard tiles are grooved for better resistance to fluing.

4832	dimensions in inches															
	A	B	C	C ₁	D	9 [Ⓢ] E 13 [Ⓢ]	F	9 [Ⓢ] G 13 [Ⓢ]	9 [Ⓢ] H 13 [Ⓢ]	9 [Ⓢ] J 13 [Ⓢ]	9 [Ⓢ] K 13 [Ⓢ]	9 [Ⓢ] L 13 [Ⓢ]	9 [Ⓢ] M 13 [Ⓢ]			
-2	1 1/4	1	—	9 1/16	4 3/4	21 1/4 25 1/4	47 1/16	11 15	7 1/4 11 1/4	9 9/8 13 3/8	11 1/4 15 1/4	9 13	16 20			
-3	1 1/2	1	—	9 1/4	4 3/4	21 1/4 25 1/4	47 1/16	11 15	7 1/4 11 1/4	9 9/8 13 3/8	11 1/4 15 1/4	9 13	16 20			
-4	2	1 1/4	5 7/16	—	4 3/4	21 1/4 25 1/4	47 1/16	11 15	7 1/4 11 1/4	9 9/8 13 3/8	11 1/4 15 1/4	9 13	16 20			
-5	2 1/2	1 1/2	—	9 13/16	7 1/4	23 7/8 27 7/8	6 1/8	11 15	7 1/4 11 1/4	9 9/8 13 3/8	11 1/4 15 1/4	9 13	18 1/2 22 1/2			
-6	3	2	6 1/16	—	7 1/4	23 7/8 27 7/8	6 1/8	11 15	7 1/4 11 1/4	9 9/8 13 3/8	11 1/4 15 1/4	9 13	18 1/2 22 1/2			
-7	4	2 1/2	6 1/16	—	7 1/4	23 7/8 27 7/8	6 1/8	11 15	7 1/4 11 1/4	9 9/8 13 3/8	11 1/4 15 1/4	9 13	18 1/2 22 1/2			

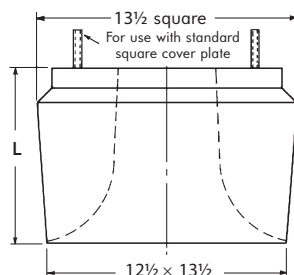
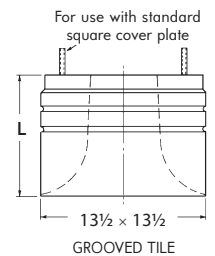

TAPERED TILES 4832- -T and 4832D- -T

For installation in arches, tapered tiles are available at no extra cost. They are also used in suspended flat roofs with a rammed or cast "collar" surrounding the tile where fluing is a problem or duty is particularly severe.

Tiles are tapered on two sides only and fit standard 4832 square mountings. Unless specified, they are assembled with one tapered side in line with pilot and flame detector holes in mounting. Material is same as standard 4832 tiles.

Tapered tiles are not grooved.

Ⓢ Tiles available in 9" and 13" depth. "D" designation signifies "Deep" (13") tile.
† Detector must be "downstream" of pilot with regard to main air spin (see Bulletin 4832).

3/4 NPT-3 holes for Pilot, Flame Detectort, and Observation Port

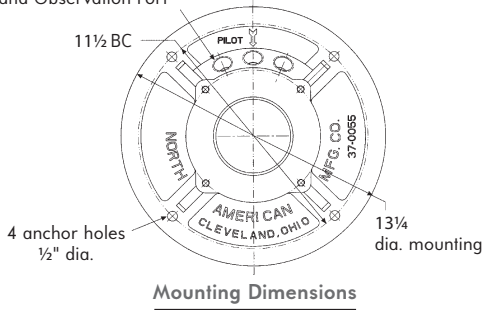

ROUND MOUNTING AND TILES
4832- -RG and 4832D- -RG

Round tiles and mountings are available at no extra cost.

Tiles are 13 3/8" diameter and 9" or 13" deep. They are made of the same refractory as standard square 4832 tiles.

Round mountings fit standard 4832 Burner bodies.

FIBER LINED FURNACE DESIGNS
(FLANGED FABRICATED MOUNTING)

For fiber lined furnaces, 4832 Burners are available with either square or round mountings and tiles. All but 2" of burner tile is encased in an expanded metal jacket. Tile must be installed so jacket does not exceed 1800 F--refer to Supplement DF-M2 for installation information. Since tile face must be flush with inside face of furnace wall, mounting flange location on jacket must be specified. "Z" dimensions are available from 2" to 15 1/2", in 1/2" increments.

Square
4832- -SZ (9" Tile)
4832D- -SZ (13" Tile)

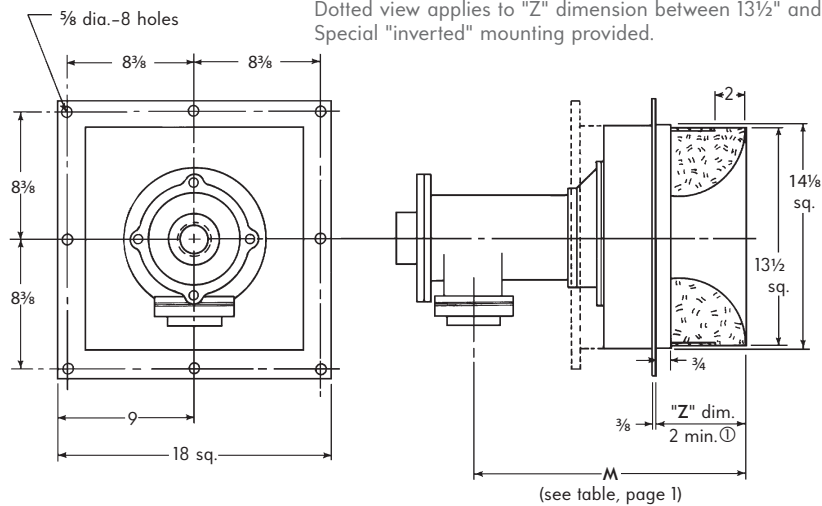

Round
4832- -RZ (9" Tile)
4832D- -RZ (13" Tile)

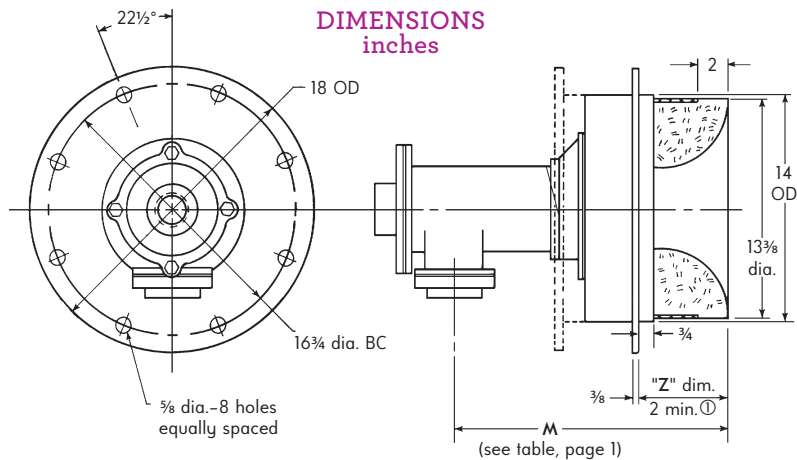

① 9" deep tile supplied for "Z" (2"-9"). 13" deep tile supplied for "Z" (9 1/2"-15 1/2").

SQUARE ROOF ("R" SERIES) TILE DESIGNS

4832-2 thru -7-SGR (9" Tile)
4832D-2 thru -7-SGR (13" Tile)
(formerly 4836-2 and -7)

DIMENSIONS
inches

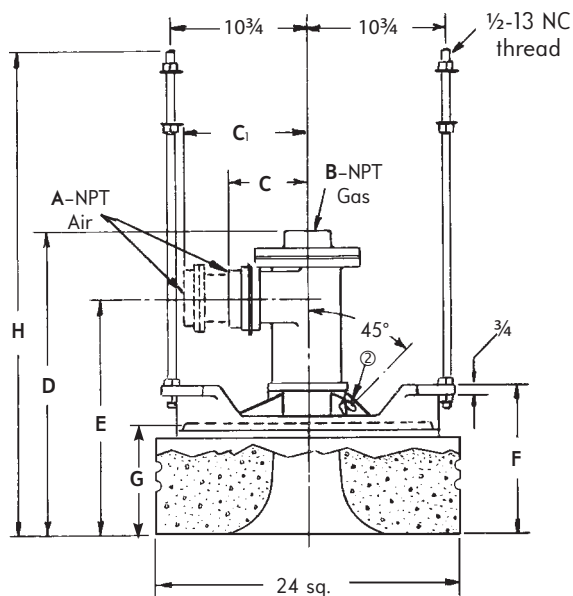

4832	dimensions in inches													
	A	B	C	C ₁	9 [Ⓛ] D 13 [Ⓛ]		9 [Ⓛ] E 13 [Ⓛ]		9 [Ⓛ] F 13 [Ⓛ]		9 [Ⓛ] G 13 [Ⓛ]		9 [Ⓛ] H 13 [Ⓛ]	
-2	1¼	1	-	9¼ ₁₆	21¼	25¼	16	20	12¾ ₁₆	16¾ ₁₆	9	13	38	42
-3	1½	1	-	9¼ ₁₆	21¼	25¼	16	20	12¾ ₁₆	16¾ ₁₆	9	13	38	42
-4	2	1¼	5¾ ₁₆	-	21¼	25¼	16	20	12¾ ₁₆	16¾ ₁₆	9	13	38	42
-5	2½	1½	-	9 ¹³ / ₁₆	23¾	25¾	18½	22½	12¾ ₁₆	16¾ ₁₆	9	13	38	42
-6	3	2	6¼ ₁₆	-	23¾	25¾	18½	22½	12¾ ₁₆	16¾ ₁₆	9	13	38	42
-7	4	2½	6¼ ₁₆	-	23¾	27¾	18½	22½	12¾ ₁₆	16¾ ₁₆	9	13	38	42

Ⓛ Tiles available in 9" and 13" depth. "D" designation signifies "Deep" (13") tile.

Ⓜ 3 holes, ¾" NPT, for pilot, flame detector and observation port, 22½° on either side of centerline. Detector must be "downstream" of pilot with regard to main air spin (see Bulletin 4832).

-8-A and -8-B ROOF ("R" Series) TILE DESIGNS

4832-8-A and -8-B/SGR (9" Tile)
4832D-8-A and -8-B/SGR (13" Tile)
(formerly 4836-8-A and -8-B)

DIMENSIONS
inches

SQUARE

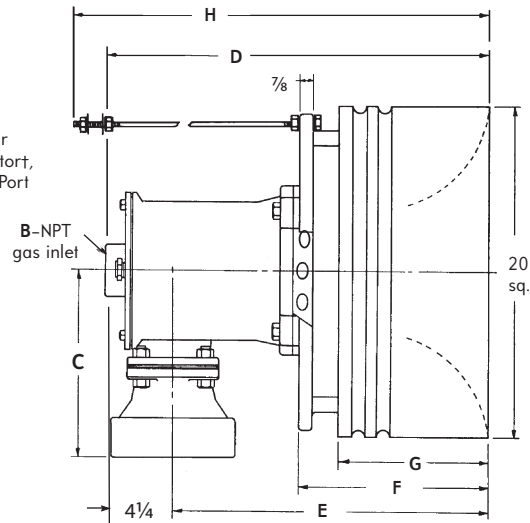
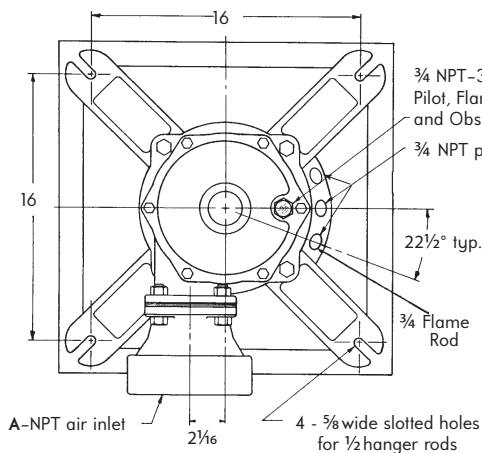

4832-8-A and -8-RGR (9" Tile)
4832D-8-A and -8-B/RGR (13" Tile)
(formerly 4836-8-A and -8-B)

ROUND

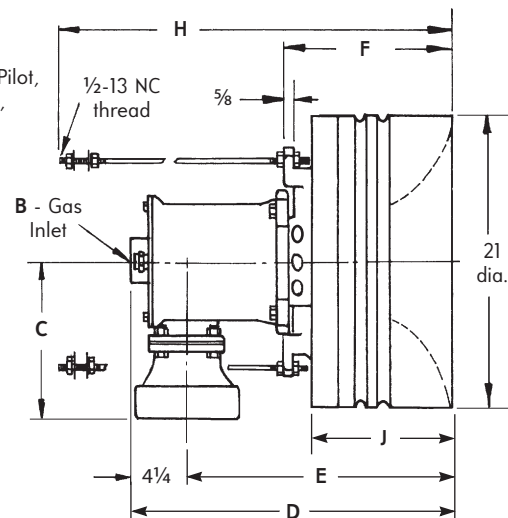
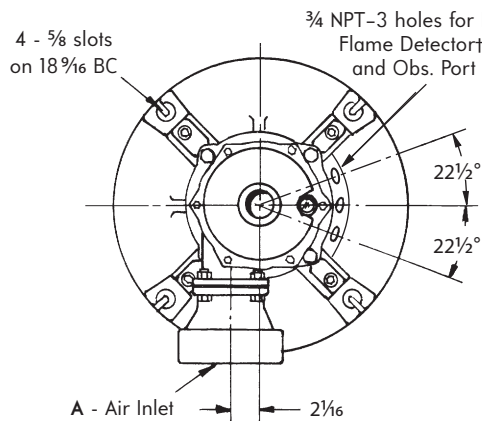

4832-8-A, -8-B	dimensions in inches														
	A	B	C	D		E		F		G		H		J	
				9 ^①	13 ^①	9 ^①	13 ^①	9 ^①	13 ^①	9 ^①	13 ^①	9 ^①	13 ^①	9 ^①	13 ^①
square tile	6	2	11 1/4	23 1/16	27 1/16	18 3/4	22 3/4	11 3/8	15 3/8	9	13	38	42	-	-
round tile	6	2	11 1/4	23 1/4	27 1/4	19	23	12 1/4	16 1/4	-	-	38	42	10 3/4	14 3/4

① Tiles available in 9" and 13" depth. "D" designation signifies "Deep" (13") tile.

† Detector must be located "downstream" of pilot in regard to main air spin (see Bulletin 4832).

DIMENSIONS SHOWN ARE SUBJECT TO CHANGE. PLEASE OBTAIN CERTIFIED PRINTS FROM FIVES NORTH AMERICAN COMBUSTION, INC.
IF SPACE LIMITATIONS OR OTHER CONSIDERATIONS MAKE EXACT DIMENSION(S) CRITICAL.

CONTACT

fna.sales@fivesgroup.com

T +1 800 626 3477 - F +1 216 373 4237

Fives North American Combustion, Inc.
4455 East 71st Street - Cleveland, OH 44105 - USA
www.fivesgroup.com



fives
Industry can do it