

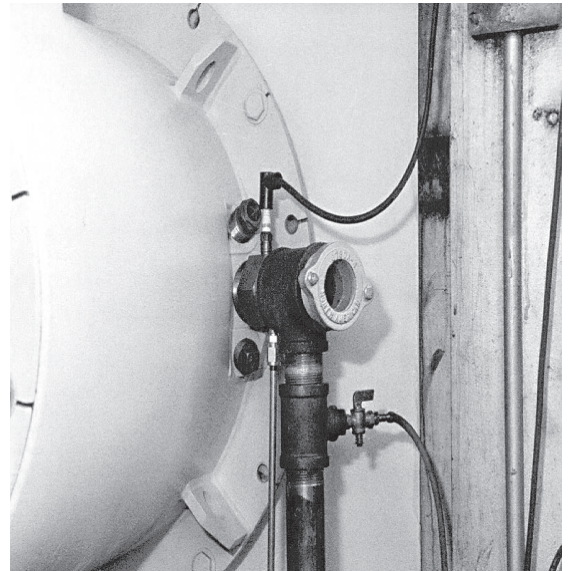

North American Nozzle-Mix Gas Pilots for Industrial Burners

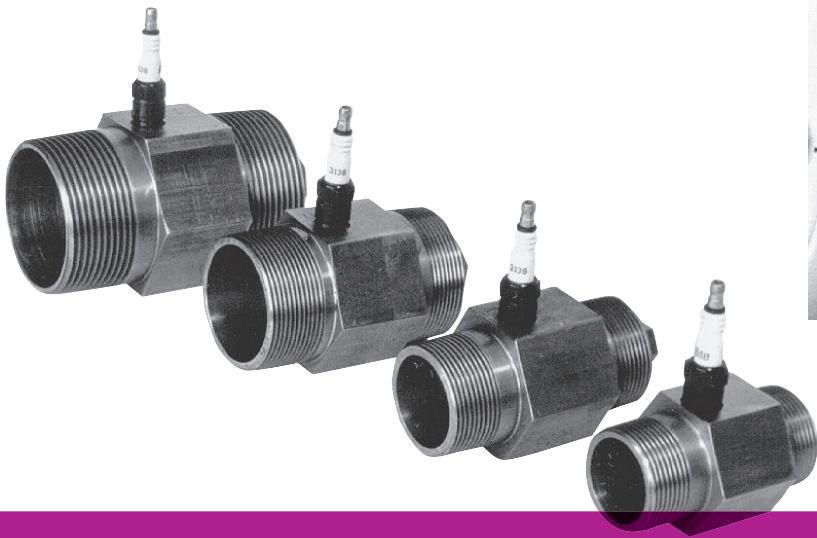

4020 Nozzle-Mix Pilot Tip

- Can be used as a small burner
- Ultimate price/performance ratio
- Serves wide range of applications
- Many sizes ($\frac{3}{4}$ " through 4"), and in 3 styles (LP, HP,CB)

Product Overview | 4020 Nozzle-Mix Pilot Tip

The 4020 Nozzle-Mix Pilots are used to light burners as alternatives to raw gas pilots or gas boosted premix pilot tips. In addition, they can be used as small burners. Nozzle-mix pilots operate with a wider stability range and with fewer components (such as mixers and boost gas tubes) to offer the ultimate price/performance ratio. To serve a wide range of applications, the pilot tip body is available from ¾" to 4" and in three different styles: Low Pressure (LP), High Pressure (HP), and Cool Boss (CB).

4020 Pilots are not recommended for the 4796/6796 Magna-Flame Burner. See individual burner literature for recommended pilots.

The "LP" version, designed to be used in place of some raw gas pilots, is an ultra low pressure pilot requiring air pressures between 0.1 and 1 osi. The "HP" version requires 1-16 osi of air pressure and can operate with a cross connected pilot regulator. The "CB" version has extra air passages to keep the mounting boss cool and operates with the same air pressure requirements as the "HP" version. The -6 and -7 pilot bodies are "sandwiched" between the metal tile and a four bolt flange. The -6 and -7 pilot bodies are "sandwiched" between a four bolt air inlet flange and a replaceable metal tile. The -6 and -7 sizes are available with an optional reduced exit size. This allows a larger pilot to be mounted on a smaller pilot boss. Use these reduced exit 4020-6/5, -6/4 or -7/6 size pilots when a stronger/higher capacity/higher velocity pilot flame is needed.

Two spark plug locations are provided on all 4020 sizes: one beside the gas inlet port and one opposite the gas port. Three ignition options are available. The standard 10 mm spark plug

(R240-2465) is provided with each tip and is recommended for use with pilots that are set rich, or when high burner backpressures are present. The optional 10 mm air purged spark (4-5635-1) is recommended for pilots that continuously fire for extended periods. For manual lighting, use an OA2-0401-1 slotted torch lighting plug.

"LP" Low Pressure
(use in place of raw gas pilot)

The "LP" style is used when only low pressure air is available; for example, a burner with inlet vortex control on the blower. The air for the pilot tip can be piped from the body of the main burner. The air pressure across the pilot tip can be set very low, 0.1 osi is often adequate if the main burner air pressure is also as low.

Because a small amount of gas is pre-mixed into the air, it is important that the gas pressure be 2-6 times as high as the air pressure to insure good pilot stability. Always install a pressure tap in the air and gas lines at the pilot tip to check for suitable pressures.

As with raw gas pilots, the "LP" works best if the main burner is always lit with the same pressure conditions as when adjusting the pilot. If the low fire burner start rate is changed, the pilot adjustment must be checked. Be aware that the "LP" will burn at high excess air conditions as well as high excess fuel conditions. Do not use a cross connected ratio regulator with the "LP". Burners with high swirl can pull the pilot away from the view of a flame detector.

4" 4020-HP Nozzle-Mix Pilot Tip
100% excess fuel
8 osi air pressure



2½" 4020-HP Nozzle-Mix Pilot Tip
100% excess fuel
8 osi air pressure



1¼" 4020-LP Nozzle-Mix Pilot Tip
100% excess fuel
0.1 osi air pressure



Capacity | 4020 Nozzle-Mix Pilot Tip

Designation	Air pressure, osi Combustion air capacity, cfh					Gas pressure osi at 100% XSF		Flame length inches at 100% XSF		Flame Length (stoic.)
	0.1	0.25	1.0	2.0	4.0	at 0.1 osi	at 1.0 osi	at 0.1 osi	at 1.0 osi	at 1.0 osi
4020-0-LP	55	90	160	—	—	0.5	6.7	7	11	6"
4020-2-LP	120	180	385	—	—	0.5	6.5	12	17	—
4020-3-LP	150	200	450	—	—	0.4	4.6	14	22	—
4020-4-LP	200	350	765	1085	—	0.4	3.6	14	26	19"
4020-5-LP	310	535	1235	1665	—	0.5	5.0	23	33	24"
4020-6-LP	600	890	1895	3195	4535	0.25	3.0	24	50	36"
4020-7-LP	1600	2540	4650	6645	9355	0.25	4.0	32	58	42"
Reduced exit port 4020-_-LP pilots with higher capacity/high velocity flames										
4020-6-LP/4	485	710	1620	—	—	0.25	2.3	24	38	22"
4050-6-LP/5	530	790	1725	—	—	0.25	2.4	24	40	24"
4020-7-LP/6	1100	1805	3765	5390	8195	0.25	2.8	30	54	28"

Maximum nominal excess air at 0.25 osi = 150% at 1.0 osi = 300%. Maximum nominal excess fuel at 0.25 osi = 180% at 1.0 osi = 200%
 Flame Lengths listed on this page are for open still air. Actual lengths when fired in a burner body will vary.
 The reduced port models of the 4020-6 and -7 pilots provide stronger, higher capacity flames than the standard version with the same exit size.

Designation	Air pressure, osi Combustion air capacity, cfh				Gas pressure osi at 100% XSF		Flame length inches at 100% XSF		Flame length (stoic.)
	1.0	4.0	8.0	16.0	at 1.0 osi	at 16 osi	at 1.0 osi	at 16 osi	at 16 osi
4020-0-HP*	45	92	115	150	0.6	6.3	8	10	6"
4020-2-HP	150	307	450	650	1.0	14.2	18	26	14"
4020-3-HP	230	430	650	915	1.2	15.1	18	30	18"
4020-4-HP	350	740	1000	1500	1.0	13.5	19	33	20"
4020-5-HP	550	1100	1600	2350	0.9	15	30	35	21"
4020-6-HP	970	2250	2975	4050	1.0	9.5	35	54	33"
4020-7-HP	2155	4600	6580	9165	1.7	10.5	44	76	48"
Reduced exit port 4020-_-HP pilots with higher capacity/high velocity flames									
4020-6-HP/4	800	1860	2765	3915	1.3	10.5	35	45	30"
4020-6-HP/5	860	2000	2960	4145	1.2	9.7	35	52	34"
4020-7-HP/6	1950	4160	5890	8503	2.2	21.4	44	64	38"

Maximum nominal excess air at 4.0 osi = 100% at 16 osi = 120%. Maximum nominal excess fuel at 4.0 osi = 130% at 16 osi = 100%.
 Flame Lengths listed on this page are for open still air. Actual lengths when fired in a burner body will vary.

* With optional 4-20667-1 Valve/Orifice.

The reduced port models of the 4030-6 and -7 pilots provide stronger, higher capacity flames than the standard version with the same exit size.

Designation	Air pressure, osi Combustion air capacity, cfh				Gas pressure osi at 50% XSF		Flame length inches at 50% XSF		Flame length (stoic.)
	1.0	4.0	8.0	16.0	at 1.0 osi	at 16 osi	at 1.0 osi	at 16 osi	at 16 osi
4020-3A-CB	150	290	410	610	1.2	16.3	15	16	12"
4020-3-CB	225	465	700	1030	1.1	23.5	16	18	14"
4020-4-CB	360	670	950	1370	1.1	14.0	18	20	15"
4020-5-CB	640	1300	1790	2520	1.2	14.5	24	30	21"

Maximum nominal excess air at 4.0 osi = 180% at 16 osi = 200% Maximum nominal excess fuel at 4.0 osi = 80% at 16 osi = 50%.

Installation | 4020 Nozzle-Mix Pilot Tip

"HP" and "CB" High Pressure Pilot (use in place of premix pilot)

The "HP" version is used in place of premix pilot assemblies. It features a built in orifice that raises the air pressure, allowing the use of a cross connected regulator.

The 4020-HP has been designed so that when the air and gas pressures are equal at the pilot tip, the flame will burn with approximately 100% excess fuel which is within the 4020's rich stability limit. This makes it very easy to set the pilot when using a cross connected ratio regulator. In many cases, the gas limiting orifice valve can be left fully open, allowing the regulator to maintain the proper air/fuel ratio for pilot use. The pilot flame is visible from the rear through an observation port if installed on an air inlet tee. Although the length of the flame can not be judged fully, it is still useful to use the observation port for setting up the pilot, and monitoring performance.

An optional air valve is available for the -0 size which includes an orifice and a pressure tap that allows the pilot to be cross connected like a "HP". At equal air and gas pressures on a -0 "HP" setup, the ratio will be very close to the rich stability limit. (See the capacity chart for the correct gas pressure at 100% excess fuel.)

The 4020-CB has extra air passages that cool the body of the tip. The cooling air also effectively lowers the excess fuel rating to 50%, shortens the flame, and increases the excess air limit. The "CB" is a good choice for use as a small burner.

INSTALLATION

Before installing, make sure the air and gas lines are free of dirt and scale. In-line filters will help prevent pilot plugging.

2. Apply anti-seize compound to the threads, and screw the tip into the pilot boss until hand tight. Do not over tighten the tip!
3. Connect pilot air and gas lines to sources upstream of all main burner control valves. Use pipe unions on the air and gas lines close to the tip. The gas valve and gas supply piping should be larger than the fitting on the tip (except in the -0 size, see accessories table for details).
4. If possible use a cross connected pilot regulator on the gas line (except the "LP"). Although the ratio stability limits are very wide on the 4020, a ratio regulator assures that the pilot will run consistently if the air pressure varies.
5. Install the spark plug in whichever port is convenient and block the other spark port with the provided pipe plug. In the -6 and -7 sizes the spark plug must be centered between air

holes. Use a 5000/6000 volt transformer for spark ignition.

6. Be certain the flame detection UV scanner on the burner is positioned to prevent proving a pilot flame that is inadequate for main flame ignition.
7. Honeywell UV scanners can monitor the pilot flame when mounted on the back of the tip if set at 25% or more of its rated capacity. However, main flame monitoring in this position is not reliable and not recommended.

Lighting "LP"

1. Close all fuel supply lines.
2. Set the burner to the conditions where the pilot will normally be started (low fire lighting condition). Set the air pressure at the tip.
3. Supply an ignition source to the spark plug and open the gas until the pilot tip lights.
4. Set the gas so that the pilot flame is large enough to light the burner reliably (gas pressures 2-6 times higher than the air pressure are recommended).

Lighting "HP"

1. Close all fuel supply lines.
2. Set the burner to the conditions where the pilot will normally be started (low fire lighting condition). Set the air pressure at the tip to 6 to 12 psi.
3. If a cross connected ratio regulator is installed, open the gas limiting orifice valve to 100% open. If there is no cross connected ratio regulator set the gas pressure so that it equals the air pressure (see capacity chart).
4. Supply an ignition source to the spark plug and open the main pilot gas valve.
5. Make flame adjustments using the gas limiting orifice valve or air valve, if necessary. Set the gas so that the pilot flame is large enough to light the burner reliably.

Installation | 4020 Nozzle-Mix Pilot Tip

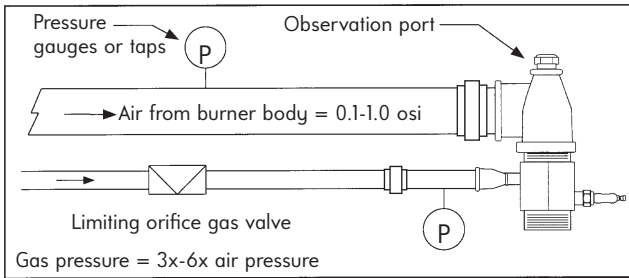

Suggested piping arrangement for 4020-LP

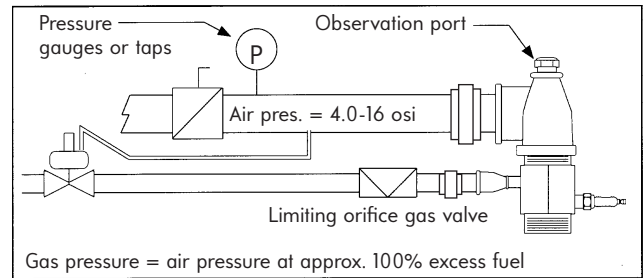

Suggested piping arrangement for 4020-HP/CB

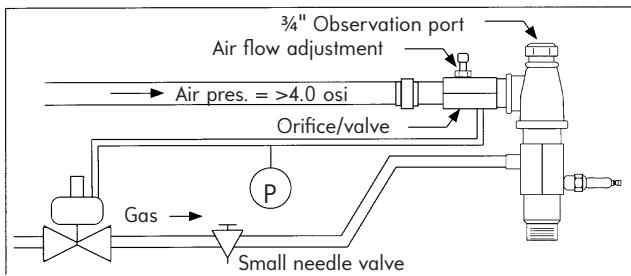

Suggested piping arrangement for 4020-0-HP (with orifice)

Pilot Accessories (Optional)

4-5635-1	Spark Plug with Purge Holes
4-20667-1	Manual Light Plug (#8 DRILL)
R590-8545	"HP" Air Orifice/Valve for -0 HP only
R930-4066	Pipe Tee 1" x 3/4" x 3/4" -0 HP only
R930-6055	1/8" Gas Valve for -0 tips
1807-01	3/8" Gas Valve for -2, -3 tips
1807-0	1/2" Gas Valve for -4, -5 tips
1807-1	3/4" Gas Valve for -6 tips
	1" Gas Valve for -7 tips

NPT TO BSPT ADAPTERS FOR 4020 GAS INLET CONNECTION

Part Number	Description
R590-0210	316 Stainless Steel adapter, male 1/8" NPT to female 1/8" BSPT
R590-0211	316 Stainless Steel adapter, male 1/4" NPT to female 1/4" BSPT
R590-0212	316 Stainless Steel adapter, male 3/8" NPT to female 3/8" BSPT
R590-0213	316 Stainless Steel adapter, male 1/2" NPT to female 1/2" BSPT
R590-0220	316 Stainless Steel reducing adapter, male 1/8" NPT to female 1/4" BSPT
R590-0221	316 Stainless Steel reducing adapter, male 1/4" NPT to female 3/8" BSPT
R590-0223	316 Stainless Steel reducing adapter, male 1/2" NPT to female 3/4" BSPT

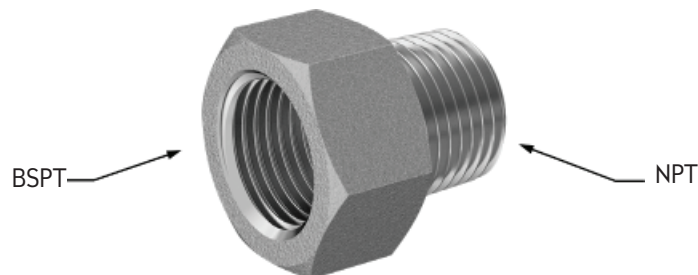

Dimensions | 4020 Nozzle-Mix Pilot Tip

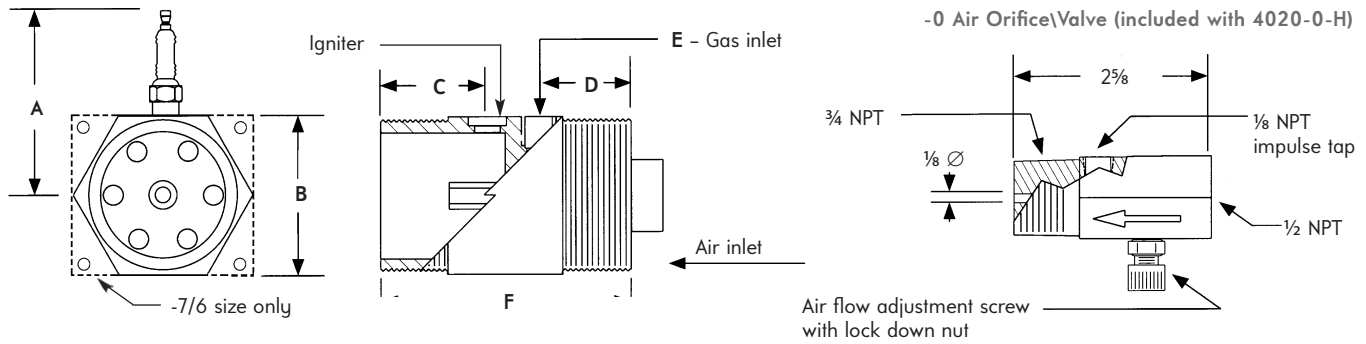

DIMENSIONS inches

Size	Inlet Pipe th'd.	Outlet Pipe th'd.	A	B	C	D	E	F	wt, lb
-0	1" mpt	3/4" mpt	3	1 1/2	2 1/4	1 1/4	1/8" NPT	4 1/2	1.5
-2	1 1/4" mpt	1 1/4" mpt	3	2	1 1/2	1 1/8	1/8" NPT	3 3/8	1.8
-3A-CB	1 1/2" mpt	1 1/2" mpt	3	2	1 3/8	1 1/8	1/4" NPT	3 3/8	2.7
-3-CB	1 1/2" mpt	1 1/2" mpt	3	2 1/4	1 3/8	1 1/8	1/4" NPT	3 3/8	2.7
-3	1 1/2" mpt	1 1/2" mpt	3 1/4	2 1/4	1 5/8	1 3/8	1/4" NPT	4	2.7
-4	2" mpt	2" mpt	3 1/2	2 1/2	1 3/4	1 3/8	1/4" NPT	4	3.6
-5	2 1/2" mpt	2 1/2" mpt	4	3	2 1/4	1 3/4	1/4" NPT	4 7/8	5.2
-6	3" fpt	3" mpt	4	4	2 3/4	2 1/2	3/8" NPT	6 1/2	10.0
-7	4" fpt	4" mpt	4 1/2	5 1/2	3	3	1/2" NPT	7 5/8	19.0

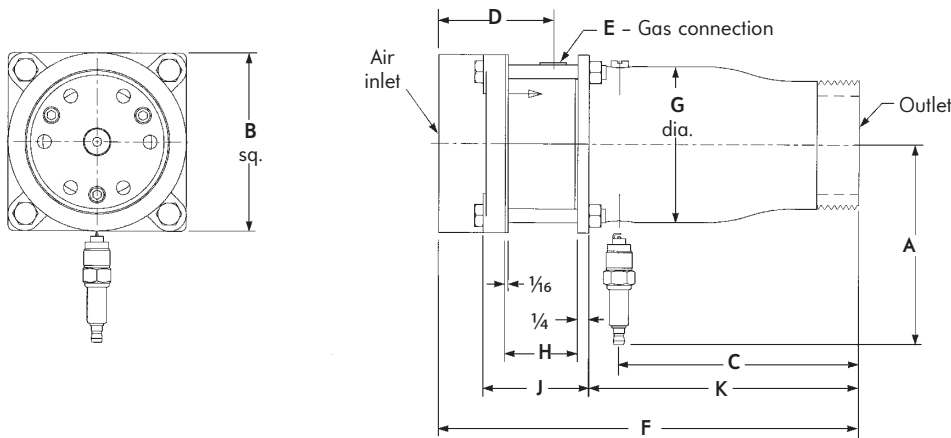

Size	Inlet pipe th'd.	Outlet pipe th'd.	A	B	C	D	E	F	G	H	J	K	wt, lb
-6-HP/4	3" fpt	2" mpt	4 1/2	4	5 3/8	2 9/16	3/8" NPT	9 7/16	3 1/2	1 5/8	2 3/8	6 1/16	11.5
-6-HP/5	3" fpt	2 1/2" mpt	4 1/2	4	5 3/8	2 9/16	3/8" NPT	9 7/16	3 1/2	1 5/8	2 3/8	6 1/16	11.5
-7-HP/6	4" fpt	3" mpt	5	5 1/2	6 1/4	2 7/8	1/2" NPT	10 7/8	4 1/2	2 1/8	3	6 15/16	21.5
-6-LP/4	3" fpt	2" mpt	4 1/2	4	5 3/8	2 9/16	3/8" NPT	9 7/16	3 1/2	1 5/8	2 3/8	6 1/16	11.5
-6-LP/5	3" fpt	2 1/2" mpt	4 1/2	4	5 3/8	2 9/16	3/8" NPT	9 7/16	3 1/2	1 5/8	2 3/8	6 1/16	11.5
-7-LP/6	4" fpt	3" mpt	5	5 1/2	6 1/4	2 7/8	1/2" NPT	10 7/8	4 1/2	2 1/8	3	6 15/16	21.5

Parts List | 4020 Nozzle-Mix Pilot Tip

4020-0-LP THRU 4020-5-LP PARTS LIST

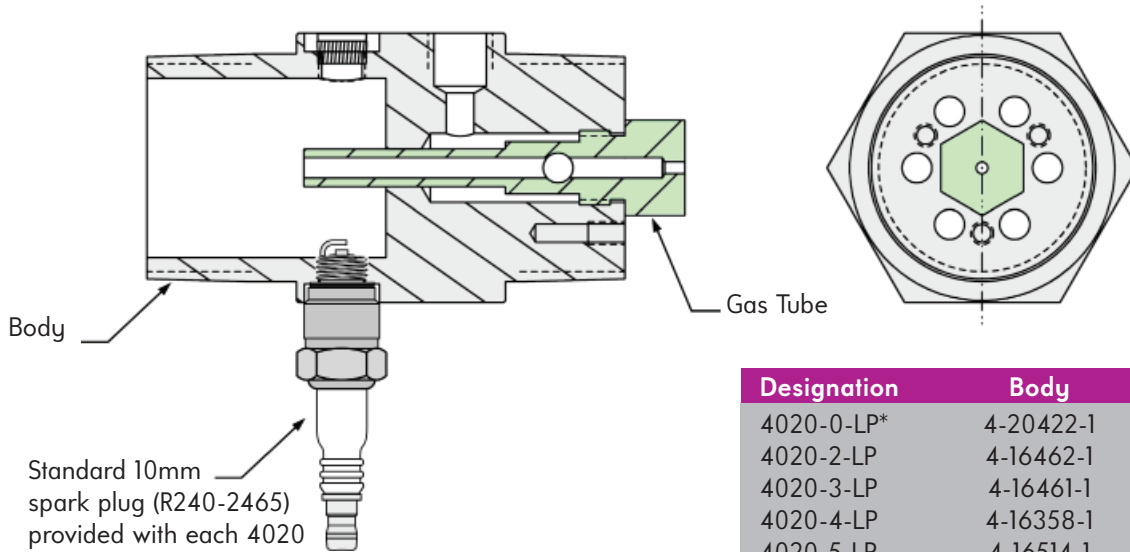

Designation	Body	Gas Tube
4020-0-LP*	4-20422-1	4-20392-1
4020-2-LP	4-16462-1	4-20392-2
4020-3-LP	4-16461-1	4-20392-3
4020-4-LP	4-16358-1	4-20392-4
4020-5-LP	4-16514-1	4-20392-5

* the -0 size also requires a mixer cap (4-20421-1) and 2 bolts (R765-1660)

4020-2-HP THRU 4020-5-HP (AND -CB) PARTS LIST

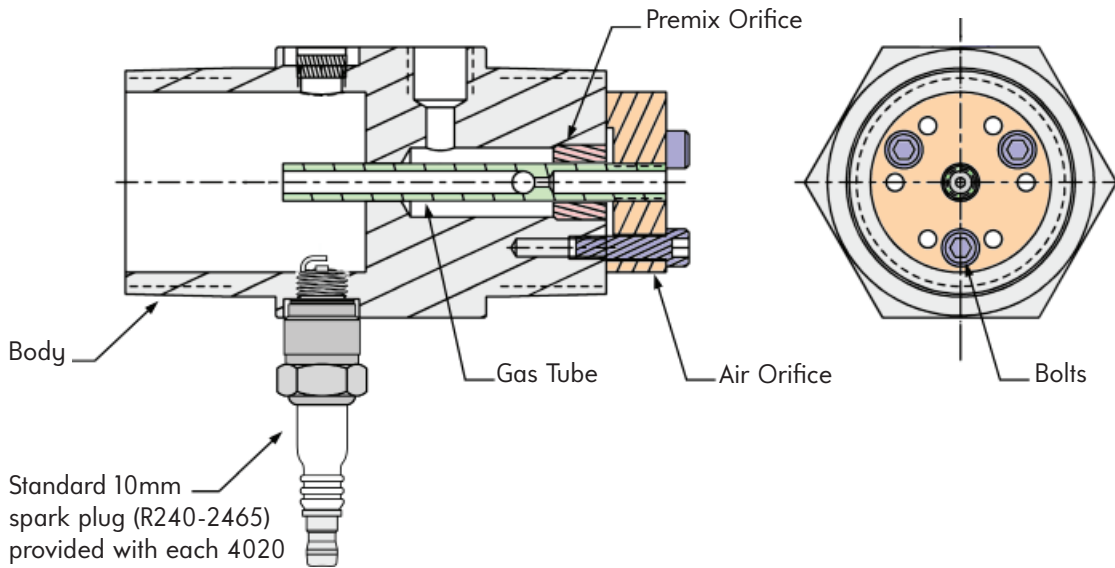

Designation	Body	Gas Tube	Air Orifice	Gas Orifice	Bolts (# REQ'D)
4020-2-HP	4-16462-1	4-16620-1	4-16621-1	4-16520-1	R765-1680 (3)
4020-3-HP	4-16461-1	4-16620-2	4-16621-2	4-16520-2	R765-1680 (3)
4020-4-HP	4-16358-1	4-16620-3	4-16621-3	4-16520-3	R765-2090 (3)
4020-5-HP	4-16514-1	4-16620-4	4-16621-4	4-16520-4	R765-2090 (3)
4020-3A-CB	4-47339-1	4-16620-1	4-47387-1	4-16520-1	R765-1670 (4)
4020-3-CB	4-16844-1	4-16620-1	4-16621-1	4-16520-1	R765-1680 (3)
4020-4-CB	4-16830-1	4-16620-2	4-16621-2	4-16520-2	R765-1680 (3)
4020-5-CB	4-16831-1	4-16620-5	4-16621-3	4-16520-3	R765-2090 (3)

Parts List | 4020 Nozzle-Mix Pilot Tip

4020-6-LP & 4020-7-LP PARTS LIST

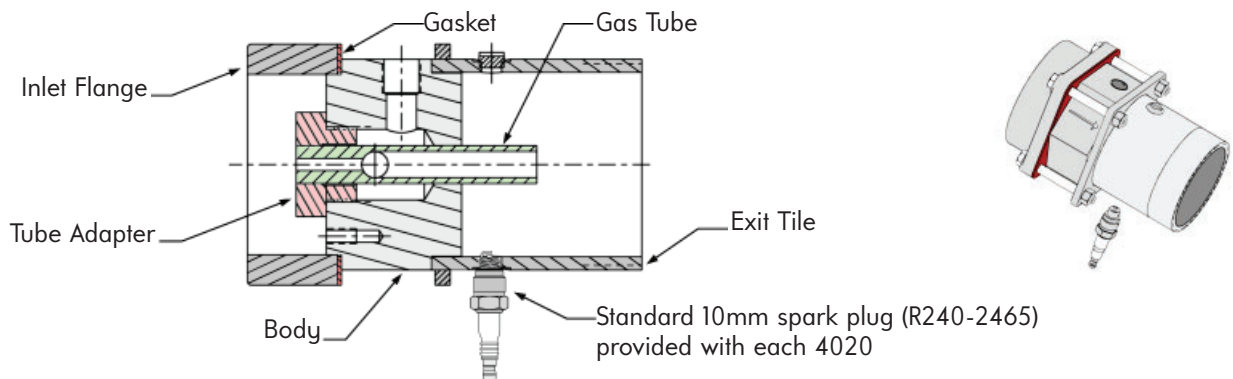

Designation	Body	Gas Tube	Tube Adapter	Inlet Flange	Gasket	Exit Tile
4020-6-LP	4-20508-1	416620-6	4-20466-1	8765-6-C (2-2310-14)	4-5371-2	4-20512-1
4020-7-LP	4-20508-2	4-16620-7	4-20466-2	8765-7-D (2-2310-7)	4-5371-3	4-20512-2
4020-6-LP/4	4-20508-1	4-16620-6	4-20466-4	8765-6-C (2-2310-14)	4-5371-2	4-20413-1
4020-6-LP/5	4-20508-1	4-16620-6	4-20466-1	8765-6-C (2-2310-14)	4-5371-2	4-20513-2
4020-7-LP/6	4-20508-2	4-16620-7	4-20466-2	8765-7-D (2-2310-7)	4-5371-3	4-20513-3

4020-6-HP & 4020-7-HP (AND -CB) PARTS LIST

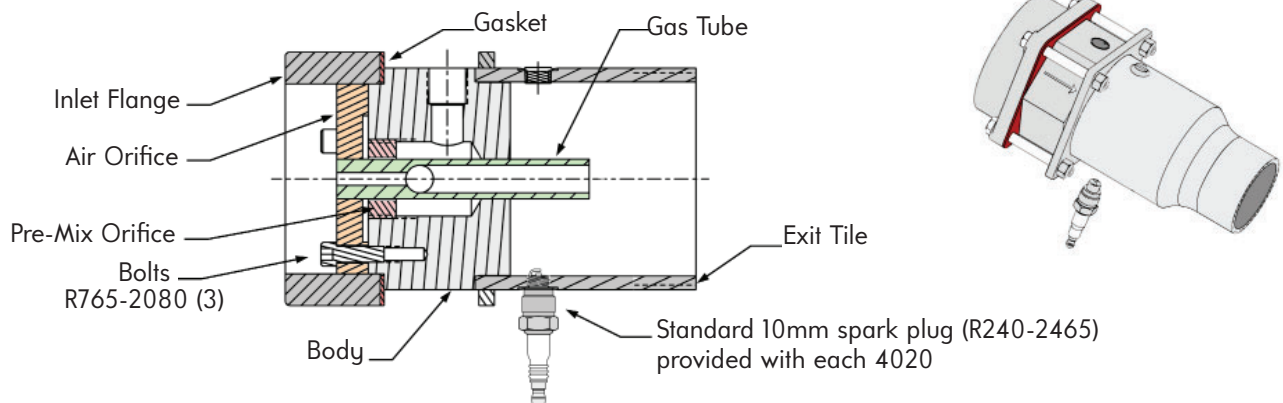

Designation	Body	Air Orifice	Pre-Mix Orifice	Gas Tube	Inlet Flange	Gasket	Exit Tile
4020-6-HP	4-20508-1	4-16621-5	4-16520-5	4-16620-6	8765-6-C (2-2310-14)	4-5371-2	4-20512-1
4020-7-HP	4-20508-2	4-16621-6	4-16520-6	4-16620-7	8765-7-D (2-2310-7)	4-5371-3	4-20512-2
4020-6-HP/4	4-20508-1	4-16621-5	4-16620-5	4-16620-6	8765-6-C (2-2310-14)	4-5371-2	4-20513-1
4020-6-HP/5	4-20508-1	4-16621-5	4-16520-5	4-16620-6	8765-6-C (2-2310-14)	4-5371-2	4-20513-2
4020-7-HP/6	4-20508-2	4-16621-6	4-16520-6	4-16620-7	8765-7-D (2-2310-7)	4-5371-3	4-20513-3

WARNING: Situations dangerous to personnel and property may exist with the operation and maintenance of any combustion equipment. The presence of fuels, oxidants, hot and cold combustion products, hot surfaces, electrical power in control and ignition circuits, etc., are inherent with any combustion application. Components in combustion systems may exceed 160°F (71°C) surface temperatures and present hot surface contact hazard. Fives North American Combustion, Inc. suggests the use of combustion systems that are in compliance with all Safety Codes, Standards, Regulations and Directives; and care in operation.

CONTACT

fna.sales@fivesgroup.com
T +1 800 626 3477 - F +1 216 373 4237

Fives North American Combustion, Inc.
4455 East 71st Street - Cleveland, OH 44105 - USA
www.fivesgroup.com

