

## North American Manual Reset and Motorized Valves



1518 Manual Reset



1519 Motorized

## 1518/1519 Automatic Shutoff Valves

- Agency approvals: UL, FM, CSA
- Durable construction
- Proof-of-closure switch
- Robust switches and terminal blocks
- High Capacity - High Pressure

---

# Product Overview | Automatic Shutoff Valves

---

## TYPICAL APPLICATIONS

North American Automatic Shutoff Valves are used in fuel supply lines on industrial furnaces, ovens, kilns, boilers, and other heating equipment. They shut off fuel automatically and instantly upon any break in electric power or the safety circuit. They cannot be opened until an interlocking safety or control circuit is complete, restoring power to the valve.

They can be suitable for pipe lines carrying a variety of gases and liquids used in processes other than combustion.

**Use Manual Reset Valves** where "manned" operation is required or preferred.

**Specify Motorized Valves** where remote or "unmanned" operation is needed. Not recommended for oil applications where on/off cycling is more than 6 cycles per hour.

1518 and 1519 Valves are for emergency automatic shutdown only--following any shutdown, close manual shutoff valves promptly.

## STANDARDS

All North American 1518 and 1519 Automatic Shutoff Valves have the following standard characteristics:

- Enclosure meets NEMA 1, 3, 3S, 4, 12, and CSA 2, 3, and 4.
- SPDT "Proof-of-Closure" switch.
- DPDT "Valve Open" switch.
- Prewired terminal block.
- Pipe sizes ¾" through 6".
- Cast iron body.
- 115 V ac/60 Hz operation (other characteristics available).
- Top assembly position is field rotatable in 90° increments.
- 6 seconds opening time for most motorized valves on 60 Hz.
- Meets Class VI valve seat leakage.

## AGENCY APPROVALS

- FM 7400
- UL 429
- CSA 6.5 C/I

## OPTIONS

- Steel body.
  - Expanded capacity ports.<sup>†</sup>
  - Companion flanges (order separately).<sup>†</sup>
- <sup>†</sup>Not available for all sizes.

Valves carry FM, UL, and CSA labels for natural gas and propane gas. All are IRI approvable. Maximum pressure differentials vary from 30 to 125 psi (depending on size). Sizes -7 and -8-XF are not suitable for #2 oil.

All valves (except 1519-8-XF, and -8-XFS. 125°F [52°C]) are suitable for ambient and fluid temperatures from -20°F to 140°F (-28°C to 60°C) on AC electrical power.

Valve action closes aggressively within one second of power loss. A two-stage latch/return motion by the operator can open a Manual Reset Valve after it is re-powered. Motorized Valves allow flow to begin within one second of powering: They are fully open in six seconds for most sizes.

PERFORM FREQUENT FIELD INSPECTIONS, LEAK TESTS, AND PROPER MAINTENANCE TO ASSURE CONTINUED SATISFACTORY VALVE PERFORMANCE. REFER TO INSTALLATION/MAINTENANCE BULLETINS.

DO NOT OPERATE MOTORIZED VALVES MORE THAN ONE CYCLE PER MINUTE FOR PERIODS OVER 15 MINUTES TO AVOID OVERHEATING MOTOR.

**Backpressure:** 1518/1519 valves are tested to 7"w.c. any higher and the valve seat may start to leak.

# Design Details | Automatic Shutoff Valves

## DESIGN DETAILS

### Top Assembly

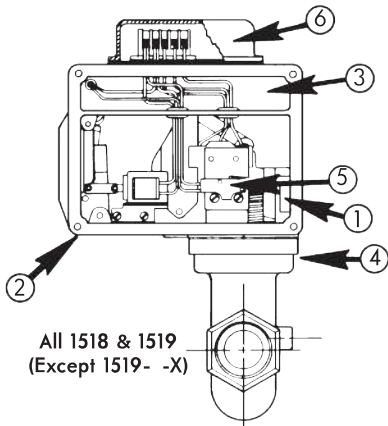

All 1518 & 1519  
(Except 1519- -X)

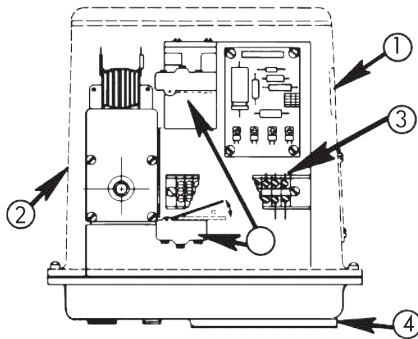

1519- -X Only

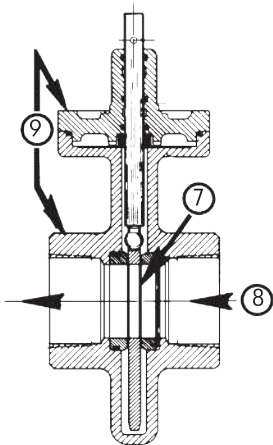

Large, two-color OPEN/SHUT indicator ① provides easy identification of valve position. Built-in wiring compartment ③ and terminal block ⑥ eliminates need for external junction box.

Terminal block ⑥ includes 12 number-coded positions.

Auxiliary switches ⑤ provide DPDT proof-of-open and SPDT "proof-of-closure" to meet insurance and approval requirements.

Good practice dictates that auxiliary switches used in main automatic shutoff valves normally be used for signal duty only.

In a block-and-vent system, blocking valve and normally open vent valve may be powered through the "proof-of-closure" switch of the main automatic shutoff valve; but all three valves must be powered through the appropriate normally open flame relay contact.

Enclosure ② meets NEMA 1, 3, 3S, 4 and 12, and CSA 2, 3 and 4 standards (when suitable electrical connections are made).

Lubrication-free design means minimal maintenance requirements. Field-rotatable top assembly ④ provides four positions for complete piping convenience.

Valves feature solenoid-actuated internal latching mechanism, except 1519- -X which have rack-and-pinion/solid state/magnetic clutch design.

When a motorized valve is energized, drive motor opens valve in 6 to 12 seconds, dependent on valve size.

### Valve Body

Metal-to-metal seating doesn't wear out; it "wears in." Disc wipes valve seat clean during each operation ⑦.

Rising stem design with straight-through flow ⑧ reduces pressure drop. Cast iron or cast steel body ⑨ to meet application requirement.

Built-in over-travel at closed position for positive shut-off.

Test connections provided both upstream and downstream of valve disc.

### Accessories

**Companion Flange Sets** (flat-faced) facilitate installation of flanged valves. Order separately.

**Wheel and Chain** assemblies allow operation of manual valves in otherwise inaccessible overhead locations. To order, specify valve with remote reset wheel and chain (2-8628-1 through -5).

Every valve is operationally tested and meets requirements of ANSI B16.104 Class VI seat leakage when it leaves our plant.

**WARNING:** Valve leak test should be performed on a quarterly basis to assure continued safe and reliable operation. Each valve should be checked with available line pressure. Absolute zero leakage may not be obtained in the field. Any valve that exceeds the allowable leakage, as set forth by your local codes or insurance requirements (15 bubbles per minute), should be removed from service and your North American representative should be contacted.

# Capacities | Automatic Shutoff Valves

## CAPACITIES and VALVE SELECTION CHARTS

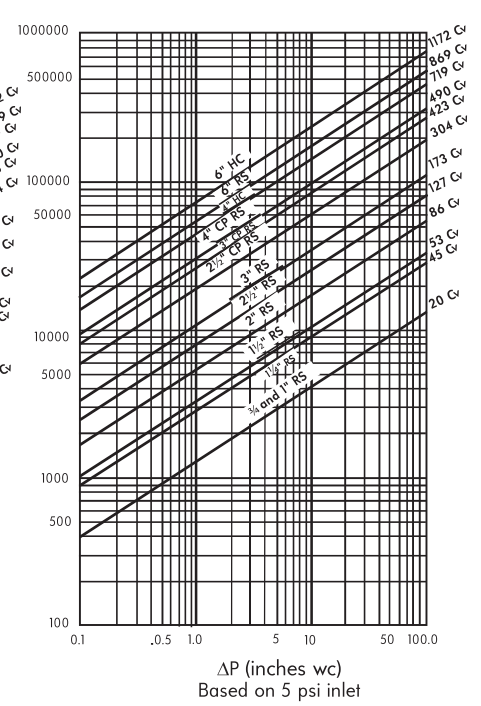
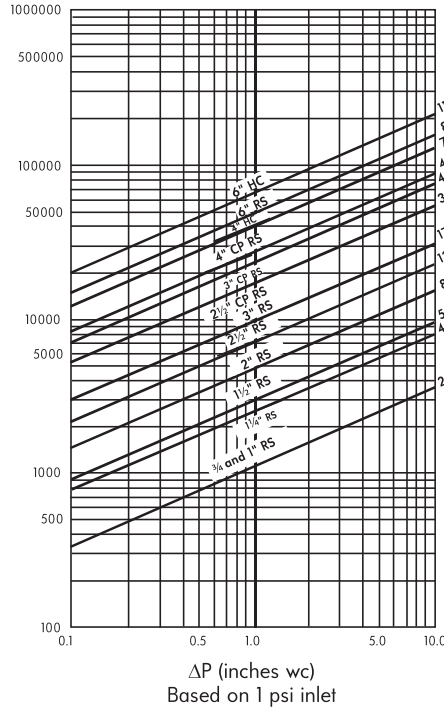
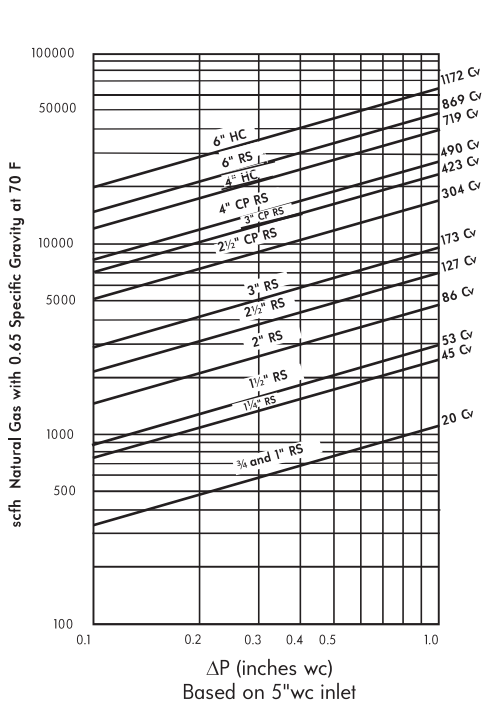

To calculate gas flow at other pressures:  $Q = 1360 Cv \left[ \frac{(P_1^2 - P_2^2)}{2 GT} \right]^{1/2}$

- Q = scfh
- G = specific gravity
- P<sub>1</sub> = inlet psia
- P<sub>2</sub> = outlet psia
- T = temp. (460 + F)

APPROXIMATE OIL CAPACITY	Valve	gph
Based on #2 Fuel Oil (60 F, 30°API) at ΔP = 1 psig	1518/19-0	1200
	1518/19-1	1300
	1518/19-2	2900

Valve Size	Cv	scfh Nat'l Gas at 1 osig ΔP w/2 psig inlet	UL/FM/CGA SANCTIONED		Max. psi at Inlet‡	Motor Timing on 60 Hz (sec.)
			Manual Reset	Motorized		
-0 (3/4")	20	1 460	1518-0	1519-0	125	6
-1 (1")	20	1 540	1518-1 1518-1-S	1519-1 1519-1-S	125	6
-2 (1 1/4")	45	3 390	1518-2	1519-2	100	6
-3 (1 1/2")	53	4 080	1518-3 1518-3-S	1519-3 1519-3-S	70	6
-4 (2")	86	6 600	1518-4 1518-4-S	1519-4 1519-4-S	70	6
-5 (2 1/2")	127	9 800	1518-5(F)	1519-5(F)	40	6
	304	23 400	1518-5-E(F) 1518-5-EFS	1519-5-E(F) 1519-5-EFS	50	6
-6 (3")	173	13 300	1518-6	1519-6	30	6
	423	33 300	1518-6-E(F) 1518-6-EFS	1519-6-E(F) 1519-6-EFS	40	6
-7 (4")	490	38 600	1518-7-EF 1518-7-EFS	1519-7-EF 1519-7-EFS	40	6
	719	56 600	—	1519-7-XF 1519-7-XFS	60	12
-8 (6")	869	68 400	1518-8-F 1518-8-FS	—	20	12
	1172	92 300	—	1519-8-XF 1519-8-XFS	50	12

‡ Maximum operating pressure differential must not exceed the maximum inlet pressure.

- (F) = Optional Flanged
- (S) = Steel Body
- (E) = Extra Capacity (CPRS)
- (F) = Standard Flanged
- (U) = Non-sanctioned
- (X) = Rack and Pinion Operator (HC)
- Blank = Standard Capacity (RS)

## ELECTRICAL DATA

### General

All standard shutoff valves are designed for operation on 115 V 60 Hz power supply. Optional voltages, Hz, direct current, or special switches, involve extra cost and extended delivery. Specify power characteristics when ordering.

A solenoid or circuit board is energized whenever valve is powered. Holding current volt-amperes are continuous once energized. Motor on any 1519 Valve is powered only during the opening stroke. The normally closed contact of a limit switch breaks motor circuit when full-open position is reached.

Flow begins within 1 second of powering. Full closure is complete within 1 second after de-energizing. Supply voltage must agree with valves nameplate voltage within -15%/+10% for proper operation.

### Series 1519- -X only

Standard 120 V power input is converted by a circuit board (no solenoid) to 90 V dc output to a magnetic clutch that is energized whenever valve is powered.

Circuit board components also act as a time delay, allowing 1/10 second response lag after main power interruption (this helps avoid nuisance shutdowns).

### Volt-ampere (VA) ratings

All solenoid, circuit board, and motor ratings are shown in Table I. Total connected load on any valve should not exceed 2000 VA. This limitation includes the maximum consumption shown in Table I plus the VA consumption of external equipment powered by the auxiliary switches at any one time.

TABLE I

Type	Valve Size (inches)	Series	VA Ratings (ac operation)	
			Opening	Holding
Manual Reset	3/4-3	1518	22	22
	6	1518	34	34
	2 1/2-4	1518- -E	34	34
Motorized	3/4-3	1519	220	22
	2 1/2-4	1519- -E	232	34
	4-6	1519- -X	376	8

### Wiring Diagrams

Each automatic shutoff valve includes one of the wiring diagrams shown below and on Page 4. Switch contacts are shown with the valve shut, unpowered.

Wiring shown above the terminal strip is internal. Wiring below terminal strip is external (field), as required.

All wires are number-coded as shown to match terminals. Terminals "2" and "DC" are neutral; all others are hot.

**WARNING:** Do not attempt field repair of valve body, top assembly, or motor drive unit. Any alterations could be dangerous, and will void all warranties.

### TYPICAL WIRING FOR ALL VALVES EXCEPT 1519- -X

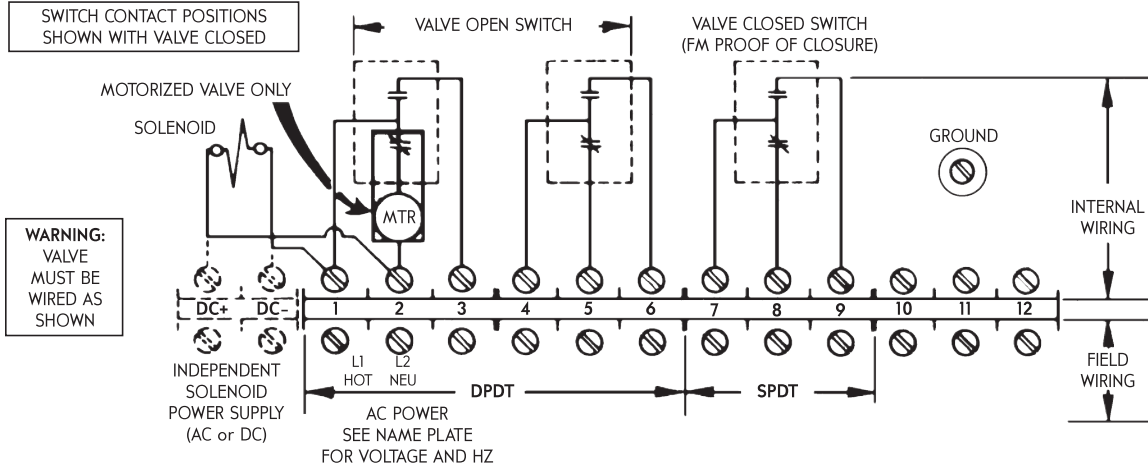

**SWITCH RATINGS**  
Total connected load not to exceed 1700 VA including values from Table I

SPDT		DPDT	
125 V ac-	15 amp	125 V ac-	10 amp
250 V ac-	15 amp	250 V ac-	10 amp
125 V dc-	0.5 amp	125 V dc-	0.3 amp
250 V dc-	0.25 amp	250 V dc-	0.15 amp

**TYPICAL SWITCH ACTION**  
(O = Open contacts; X = Closed contacts between indicated terminals.)

Valve Position	Valve Open Switch			Valve Closed Switch	
	1-3	4-5	4-6	7-8	7-9
Fully Closed	O	X	O	X	O
Intermediate	O	X	O	O	X
Fully Open	X	O	X	O	X

## WIRING FOR 1519- -X ONLY

SWITCH CONTACT POSITIONS SHOWN WITH VALVE CLOSED

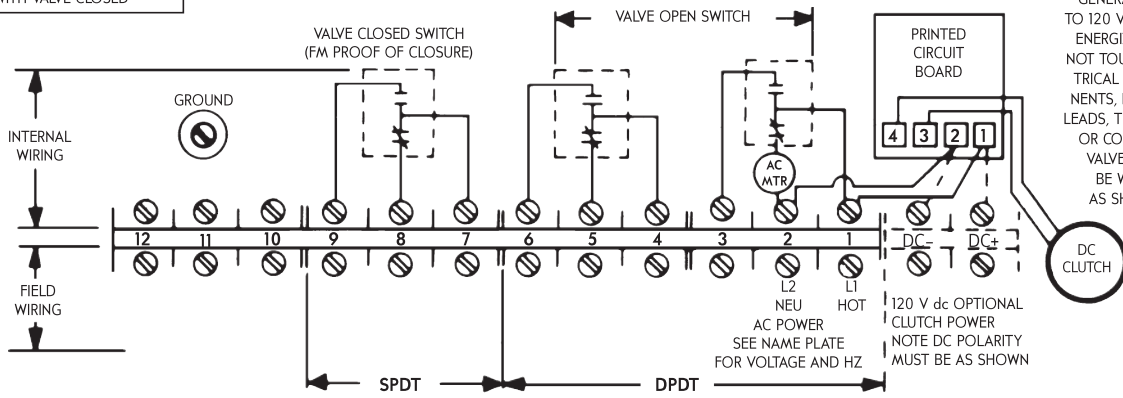

**WARNING:**  
CIRCUIT BOARD GENERATES 90 TO 120 V dc WHEN ENERGIZED. DO NOT TOUCH ELECTRICAL COMPONENTS, EXPOSED LEADS, TERMINALS, OR CONTACTS. VALVE MUST BE WIRED AS SHOWN.

**SWITCH RATINGS**  
Total connected load not to exceed 1600 VA including values from Table I

SPDT		DPDT	
125 V ac-	20 amp	125 V ac-	10 amp
250 V ac-	20 amp	250 V ac-	10 amp
125 V dc-	0.5 amp	125 V dc-	0.3 amp
250 V dc-	0.25 amp	250 V dc-	0.15 amp

**TYPICAL SWITCH ACTION**  
(O = Open contacts; X = Closed contacts between indicated terminals.)

Valve Position	Valve Open Switch			Valve Closed Switch	
	1-3	4-5	4-6	7-8	7-9
Fully Closed	O	X	O	X	O
Intermediate	O	X	O	O	X
Fully Open	X	O	X	O	X

## VALVE BODY AND TRIM

Standard 1518 Manual Reset and 1519 Motorized Valves have cast iron bodies with internal materials listed in table below under "Standard Trim." Cast steel bodies are available. They are specified by adding an "S" after the code number for pipe size. Example: 1518-4-S.

Other trim packages are available per request. Please contact engineering. i.e. different body, seat, disc, spring pin, and body seal and bumper materials are available.

\* Body seal bumper.

Note: For "U" valves, please submit fuel analysis to North American office to determine suitability of valves.

Body and Bonnet Specifications		Standard Body and Bonnet	"S" Body and Bonnet
A	Material	CI, G3000, CL30	Cast Steel
B	ASTM Spec	A159	A216-WCB

### Valve Internals

Item No.	Description	Standard Trim			
		¾ - 2"	2 ½ - 3"	4 - 6"	2 ½ - 4"
A	Body	Cast Iron			
B	Bonnet	ASTM A126, Class B			
3	Seat	400 SS			
4	Disc	Hardened Ductile Iron			
5	Follower Ring	PEEK			
6	Seat O-Ring*	Buna N			
7	Body O-Ring*	Buna N			
8	Wavy Spring	300 SS			
9	Stem	17-4 PH SS			
10	Spring pin (when required)	Carbon Steel			
11	Stem O-Ring*	Buna N			
12	Striker Plate	17-7 PH SS			
13	Bumper*	Buna N			
—	Clevis	Ductile Iron			

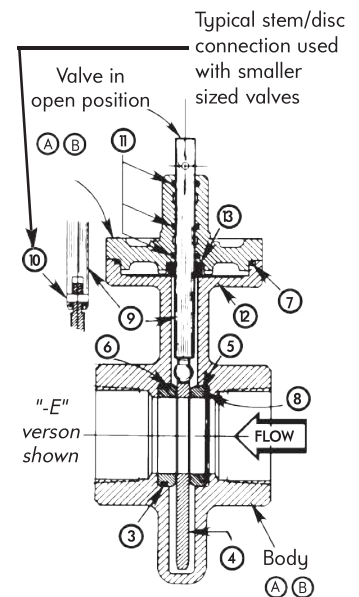

① Compression Ring  
② For 6" 808, and 4" & 6" 7000 valves only; not shown in illustration



# Dimensions | Automatic Shutoff Valves

1518  
MANUAL  
RESET

Fig. 1

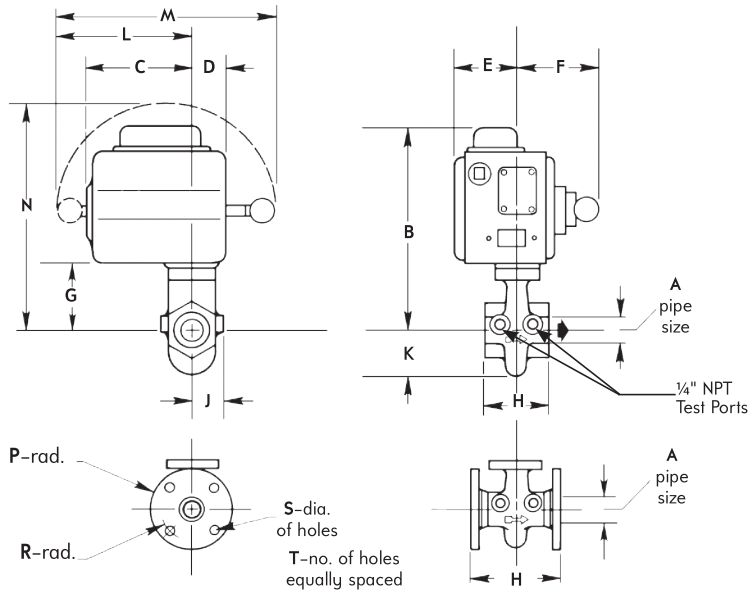

All valve positions are as shown when shipped as a separate item.

Orientation may be different when part of packaged fuel train.

Valve designation	Fig. no.	dimensions in inches													
		A	B	C	D	E	F	G	H	J	K	L	M	N	
1518-0	1	3/4	11 3/16	5 7/16	1 7/8	3 1/2	4 1/2	3 3/8	3 13/16	1 3/16	2	7 1/8	11 1/2	11 19/32	
1518-1-(S)	1	1	11 3/16	5 7/16	1 7/8	3 1/2	4 1/2	3 3/8	3 13/16	1 3/16	2	7 1/8	11 1/2	11 19/32	
1518-2	1	1 1/4	11 3/4	5 7/16	1 7/8	3 1/2	4 1/2	3 11/16	4	1 1/16	2 7/16	7 1/8	11 1/2	12 1/8	
1518-3-(S)	1	1 1/2	12 7/32	5 7/16	1 7/8	3 1/2	4 1/2	4 1/8	4	1 13/16	2 11/16	7 1/8	11 1/2	12 19/32	
1518-4-(S)	1	2	13 11/16	7 19/32	2 3/8	3 1/2	5 5/8	4 11/16	4 3/8	1 7/8	3 1/4	8 9/16	13 1/8	14 3/8	
1518-5	1	2 1/2	13 9/16	7 19/32	2 3/8	3 1/2	5 1/2	4 5/8	5	2 1/4	3 1/2	8 9/16	13 3/8	14 1/4	
1518-5-F	1A	2 1/2	13 9/16	7 19/32	2 3/8	3 1/2	5 1/2	4 5/8	7 1/2	2	3 1/2	8 9/16	13 3/8	14 1/4	
1518-5-E	1	2 1/2	14 9/16	10 5/8	2 27/32	4 3/16	5 3/4	5 13/16	5	2 1/4	4 5/16	10 15/16	15 1/8	14 9/16	
1518-5-EF(S)	1A	2 1/2	14 9/16	10 5/8	2 27/32	4 3/16	5 3/4	6 9/16	7 1/2	2 1/4	4 1/2	10 15/16	15 1/8	14 9/16	
1518-6	1	3	13 13/16	7 19/32	2 3/8	3 1/2	5 5/8	4 13/16	5 3/16	2 9/16	2 15/16	8 9/16	13 3/8	14 1/2	
1518-6-E	1	3	15 5/32	10 5/8	2 3/8	4 3/16	5 3/4	6 9/16	5 1/2	2 9/16	5 1/8	10 15/16	15 1/8	17 31/32	
1518-6-EF(S)	1A	3	15 5/32	10 5/8	2 27/32	4 3/16	5 3/4	6 9/16	8	2 9/16	5 7/32	10 15/16	15 1/8	17 31/32	
1518-7-EF(S)	1A	4	15 5/32	10 5/8	2 27/32	4 3/16	5 3/4	6 9/16	9	2 9/16	5 9/16	10 15/16	15 1/8	17 31/32	
1518-8-F(S)	1A	6	20 3/4	10 5/8	2 27/32	4 3/16	5 3/4	10 7/8	10 1/2	3 1/4	7 1/2	10 15/16	15 1/8	23 7/16	

Valve designation	Fig. no.	dimensions in inches				wt, lb
		P	R	S	T	
1518-0	1	—	—	—	—	17
1518-1-(S)	1	—	—	—	—	17
1518-2	1	—	—	—	—	19
1518-3-(S)	1	—	—	—	—	20
1518-4-(S)	1	—	—	—	—	31
1518-5	1	—	—	—	—	45
1518-5-F	1A	3 1/2	2 3/4	3/4	(4)	70
1518-5-E	1	—	—	—	—	46
1518-5-EF(S)	1A	3 1/2	2 3/4	3/4	(4)	89
1518-6	1	—	—	—	—	45
1518-6-E	1	—	—	—	—	53
1518-6-EF(S)	1A	3 3/4	3	3/4	(4)	95
1518-7-EF(S)	1A	4 1/2	3 3/4	3/4	(8)	123
1518-8-F(S)	1A	5 1/2	4 3/4	7/8	(8)	140

F = Standard Flanged  
(S) = Optional Steel Body  
S = Standard Steel Body

E = Extra Capacity  
X = Rack & Pinion Operator

**WARNING:** Valve leak test should be performed on a quarterly basis to assure continued safe and reliable operation. Each valve should be checked with available line pressure. Absolute zero leakage may not be obtained in the field. Any valve that exceeds the allowable leakage, as set forth by your local codes or insurance requirements (15 bubbles per minute), should be removed from service and your North American representative should be contacted.

# Dimensions | Automatic Shutoff Valves

## 1519 MOTORIZED

Fig. 2

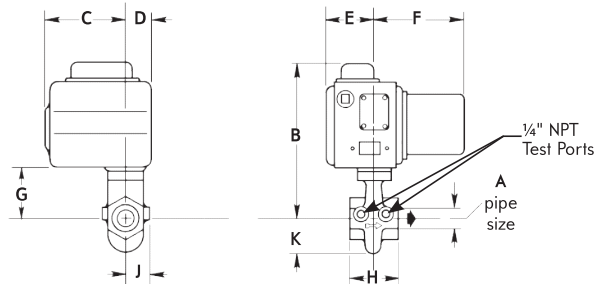

Fig. 2A

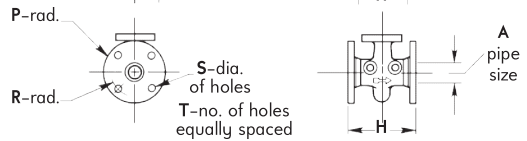
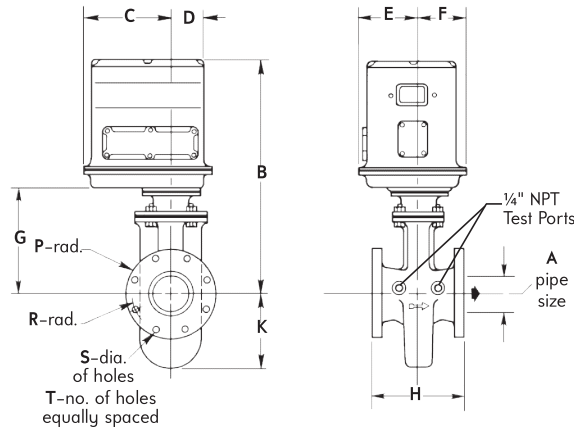

Fig. 3



All valve positions are as shown when shipped as a separate item.

Orientation may be different when part of packaged fuel train.

Valve designation	Fig. no.	dimensions in inches														wt, lb
		A	B	C	D	E	F	G	H	J	K	P	R	S	T	
1519-0	2	3/4	11 3/16	5 1/2	1 7/8	3 1/2	7 11/32	3 1/8	3 13/16	1 9/32	2	—	—	—	—	23
1519-1-(S)	2	1	11 3/16	5 1/2	1 7/8	3 1/2	7 11/32	3 3/8	3 13/16	1 9/32	2	—	—	—	—	23
1519-2	2	1 1/4	11 3/4	5 1/2	1 7/8	3 1/2	7 11/32	3 11/16	4	1 1/16	2 7/16	—	—	—	—	24
1519-3-(S)	2	1 1/2	12 7/32	5 1/2	1 7/8	3 1/2	7 11/32	4 1/8	4	1 1/16	2 11/16	—	—	—	—	25
1519-4-(S)	2	2	13 11/16	7 19/32	2 3/8	3 1/2	7 1/2	4 11/16	4 3/8	1 11/16	3 1/4	—	—	—	—	34
1519-5	2	2 1/2	13 9/16	7 19/32	2 3/8	3 1/2	7 1/2	4 5/8	5	2 1/4	3 1/2	—	—	—	—	37
1519-5-F	2A	2 1/2	13 9/16	7 19/32	2 3/8	3 1/2	7 1/2	4 5/8	7 1/2	2	3 1/2	3 1/2	2 3/4	3/4	(4)	75
1519-5-E	2	2 1/2	14 9/16	10 5/8	2 27/32	4 7/32	7 1/2	5 3/16	5	2 1/4	4 5/16	—	—	—	—	50
1519-5-EF(S)	2A	2 1/2	14 9/16	10 5/8	2 27/32	4 7/32	7 1/2	6 9/16	7 1/2	2 1/4	4 1/2	3 1/2	2 3/4	3/4	(4)	93
1519-6	2	3	13 13/16	7 19/32	2 27/32	3 1/2	7 1/2	4 13/16	5 3/16	2 9/16	2 15/16	—	—	—	—	42
1519-6-E	2	3	15 9/32	10 5/8	2 3/8	4 7/32	7 1/2	6 9/16	5 1/2	2 9/16	5 1/8	—	—	—	—	53
1519-6-EF(S)	2A	3	15 9/32	10 5/8	2 27/32	4 7/32	7 1/2	6 9/16	8	2 9/16	5 7/32	3 3/4	3	3/4	(4)	95
1519-7-EF(S)	2A	4	15 9/32	10 5/8	2 27/32	4 7/32	7 1/2	6 9/16	9	2 9/16	5 9/16	4 1/2	3 3/4	3/4	(8)	133
1519-7-XF(S)	3	4	23 7/8	8 5/8	3 7/8	4 7/32	4 9/16	10 7/8	9	—	7 5/16	4 1/2	3 3/4	3/4	(8)	195
1519-8-XF(S)	3	6	25	8 5/8	3 7/8	5 13/16	4 9/16	12 1/16	10 1/2	—	8 3/8	5 1/2	4 3/4	7/8	(8)	215

DIMENSIONS SHOWN ARE SUBJECT TO CHANGE. PLEASE OBTAIN CERTIFIED PRINTS FROM FIVES NORTH AMERICAN COMBUSTION, INC. IF SPACE LIMITATIONS OR OTHER CONSIDERATIONS MAKE EXACT DIMENSION(S) CRITICAL.



# Parts Numbers for Specials | Automatic Shutoff Valves

Table 1: 1518/1519 Ordering  
check all that apply

Valve Size	Flow Capacity	Body Connection	Body Seals & Bumper Material	Body Material	Internal Trim Package
<input type="checkbox"/> ¾"	<input type="checkbox"/> Standard capacity	<input type="checkbox"/> ANSI (NPT) Threaded	<input type="checkbox"/> Buna O-rings and Buna bumper	<input type="checkbox"/> Cast Iron	<input type="checkbox"/> Trim package 1
<input type="checkbox"/> 1"	<input type="checkbox"/> CP body construction	<input type="checkbox"/> ANSI flanged (PN20) 150#	<input type="checkbox"/> Viton O-rings and Buna bumper	<input type="checkbox"/> Carbon Steel	<input type="checkbox"/> Trim package 2
<input type="checkbox"/> 1¼"	<input type="checkbox"/> High capacity	—	<input type="checkbox"/> Viton O-rings and Viton bumper	<input type="checkbox"/> Stainless Steel	—
<input type="checkbox"/> 1½"	—	—	<input type="checkbox"/> Omniflex O-rings and Buna bumper	—	—
<input type="checkbox"/> 2"	—	—	<input type="checkbox"/> Omniflex O-rings and Viton bumper	—	—
<input type="checkbox"/> 2½"	—	—	—	—	—
<input type="checkbox"/> 3"	—	—	—	—	—
<input type="checkbox"/> 4"	—	—	—	—	—
<input type="checkbox"/> 6"	—	—	—	—	—

Reset	Solenoid or Circuit Voltage	Motor Voltage (Leave blank for manual reset)	Opening Time	Switch Option	Enclosure Rating
<input type="checkbox"/> Manual (Standard handle option)	<input type="checkbox"/> 115VAC/50Hz	<input type="checkbox"/> 115VAC/50Hz	<input type="checkbox"/> None (Manual only)	<input type="checkbox"/> None	<input type="checkbox"/> NEMA 4
<input type="checkbox"/> Automatic	<input type="checkbox"/> 115VAC/60Hz	<input type="checkbox"/> 115VAC/60Hz	<input type="checkbox"/> 2.5 seconds	<input type="checkbox"/> VOS1/VCSI	<input type="checkbox"/> NEMA 4X
	<input type="checkbox"/> 230VAC/50Hz	<input type="checkbox"/> 230VAC/50Hz	<input type="checkbox"/> 6 seconds	<input type="checkbox"/> VOS2/VCS2	—
	<input type="checkbox"/> 230VSC/60Hz	<input type="checkbox"/> 230VAC/60Hz	<input type="checkbox"/> 12 seconds	<input type="checkbox"/> VOS2/VCSI	—
	<input type="checkbox"/> 208VAC/50Hz	<input type="checkbox"/> 208VAC/60Hz	—	—	—
	<input type="checkbox"/> 24VDC	<input type="checkbox"/> 24VDC	—	—	—
	<input type="checkbox"/> 120VDC	—	—	—	—
—	—	—	—	—	—
—	—	—	—	—	—

**WARNING:** Situations dangerous to personnel and property may exist with the operation and maintenance of any combustion equipment. The presence of fuels, oxidants, hot and cold combustion products, hot surfaces, electrical power in control and ignition circuits, etc., are inherent with any combustion application. Components in combustion systems may exceed 160°F (71°C) surface temperatures and present hot surface contact hazard. Fives North American Combustion, Inc. suggests the use of combustion systems that are in compliance with all Safety Codes, Standards, Regulations and Directives; and care in operation.

## CONTACT

fna.sales@fivesgroup.com  
T +1 800 626 3477 - F +1 216 373 4237

Fives North American Combustion, Inc.  
4455 East 71st Street - Cleveland, OH 44105 - USA  
www.fivesgroup.com



fives  
Industry can do it