



North American Wafer Butterfly Valves



1136A, 1146 and 1156 Wafer Valves

- Used for controlling low pressure combustion air flow
- Rugged and lightweight
- Stainless steel shaft, bodies are heat-resistant cast iron

Product Overview | Wafer Valves

North American Wafer Butterfly Valves are rugged, lightweight, and used for controlling low pressure combustion air* flow. They sandwich between companion flanges with two locating holes on the valve body (ANSI Class 150 style for 3" to 14" ; RPM style for 16" to 22"). All wafer valves have stainless steel shafts; bodies and discs are heat-resistant cast iron. All are suitable for inlet pressures up to 10 psig, provided differential pressures across valves, at high fire flow rate, are limited to 1 psi for 1145 and 1146 Valves, 2 psi for all others. No lubrication is required. Seven types are available.

1136A Motorized Reduced Port Valves, for combustion air* up to 250°F, have a port diameter one size less than line size to facilitate proper valve sizing without the expense of reducing pipes at the valve. These valves feature self-cleaning discs. 1136A Valves are available with bracket and linkage for most standard control motors. Available in 3" to 14" sizes. 1136A valves are not available for manual operation.

1145 (Manual) and 1146 (Motorized) Hot Air Valves, for combustion air* at temperatures from 250°F to 700°F, have adequate clearance to prevent binding due to thermal expansion. Clearance changes with temperature, so cold valves leak through the body/disc gap noticeably. To minimize leakage, the valves are not recommended for service below 250°F. 1145 Valves have locking handles for manual operation. 1146 Valves for motorized control are available (through 22") with bracket and linkage for most standard control motors. Larger valves require remote mounted operators. Available in 3" to 22" pipe sizes.

1145-H (Manual) and 1146-H (Motorized) High Temperature Air Valves: Identical to the 1145/1146 valves except for combustion air* at the temperature range of (700-1200°F), these valves have larger clearance to prevent binding due to thermal expansion at much higher temperatures. Clearance changes with temperature, so valves will leak noticeably through the body/disc gap at lower temperatures. To minimize leakage, the valves are not recommended for service below 700°F. Available with all options that are offered with the 1145/1146.

* Not for use with fuel gases.

1155 (Manual) and 1156 (Motorized) Valves, for combustion air* up to 250°F, are available in 3" to 30" pipe sizes. Available with all options that are offered with the 1145/1146.



1145 or 1155 Manual Wafer Valve

Sizing. Full port wafer valves in lines of the same pipe size give increasing flow for a fixed pressure drop until they are about 60° or 70° open. At greater openings, flow does not increase appreciably, although pressure drop across the valve falls off rapidly--downstream piping or burners, not the valve, become the limiting resistance in the system. At 90° open, the valve's flow resistance is negligible--its pressure drop is practically zero, and it can be ignored in pressure drop calculations. For control sensitivity, wafer valves should be selected for maximum flow at not more than 70° open.

Capacities | Wafer Valves

WAFER VALVE CAPACITIES

scfh at 1" w.c. pressure drop (70°F air) and 0.25 PSIG, upstream pressure

Pipe size	1146, 1156		1136A	
	wide open	70° open	wide open	70° open
-6 (3")	18 500	9 650	9 500	4 940
-7 (4")	27 200	14 300	18 500	9 650
-8 (6")	60 000	35 000	27 200	14 300
-9 (8")	125 000	56 000	60 000	35 000
-10 (10")	202 000	88 500	125 000	56 000
-12 (12")	303 000	137 000	202 000	88 500
-14 (14")	400 000	195 000	303 000	137 000
-16 (16")	530 000	254 000	-	-
-18 (18")	670 000	320 000	-	-
-20 (20")	845 000	404 000	-	-
-22 (22")	1 040 000	498 000	-	-
-24 (24")	1 260 000	600 000	-	-
-30 (30")	1 720 000	825 000	-	-

OBSOLETE - See Sheet 1146/1156-3
OBSOLETE - See Sheet 1146/1156-3

WAFER VALVE LEAK RATES

All leak rates evaluated with valve in closed position, and 0.25 PSIG pressure upstream. 1136A/55/56 leak rates are evaluated at 70°F, those for 1145/1146 are at 250°F, while those for 1145/1146-H are at 700°F.

Pipe Size	1136A	1155/1156	1145/1146	1145/1146-H
-6 (3")	165	341	369	376
-7 (4")	213	373	600	578
-8 (6")	694	672	1300	1259
-9 (8")	791	943	2268	2202
-10 (10")	996	1159	3460	3364
-12 (12")	1224	1410	5087	4940
-14 (14")	1410	1929	7005	6855
-16 (16")	—	2494	9000	8735
-18 (18")	—	3337	10961	10688
-20 (20")	—	3349	13722	13451
-22 (22")	—	5276	16913	16431
-24 (24")	—	5784	20302	19709
-30 (30")	—	7245	30210	29339

OBSOLETE - See Sheet 1146/1156-3
OBSOLETE - See Sheet 1146/1156-3

SPECIFICATIONS / CONSTRUCTION

Valve designation	Maximum inlet pressure, psi	Maximum temperature, F	Minimum ambient temperature, F	Body	Disc	Shaft
1155/1156	25	250	-20	heat-resistant	heat-resistant	stainless steel
1136A				cast iron	cast iron	
1145/1146	25	700	-20	"	"	"
1145/1146-H ^①	25	1200	-20	"	"	"

^① For 1146-H Valves, consider specifying "1232 B & L" (for additional charge) with standoff bracket to help protect control motor from heat.

WARNING: Situations dangerous to personnel and property may exist with the operation and maintenance of any combustion equipment. The presence of fuels, oxidants, hot and cold combustion products, hot surfaces, electrical power in control and ignition circuits, etc., are inherent with any combustion application. Components in combustion systems may exceed 160°F (71°C) surface temperatures and present hot surface contact hazard. Fives North American Combustion, Inc. suggests the use of combustion systems that are in compliance with all Safety Codes, Standards, Regulations and Directives; and care in operation.

WAFER VALVES

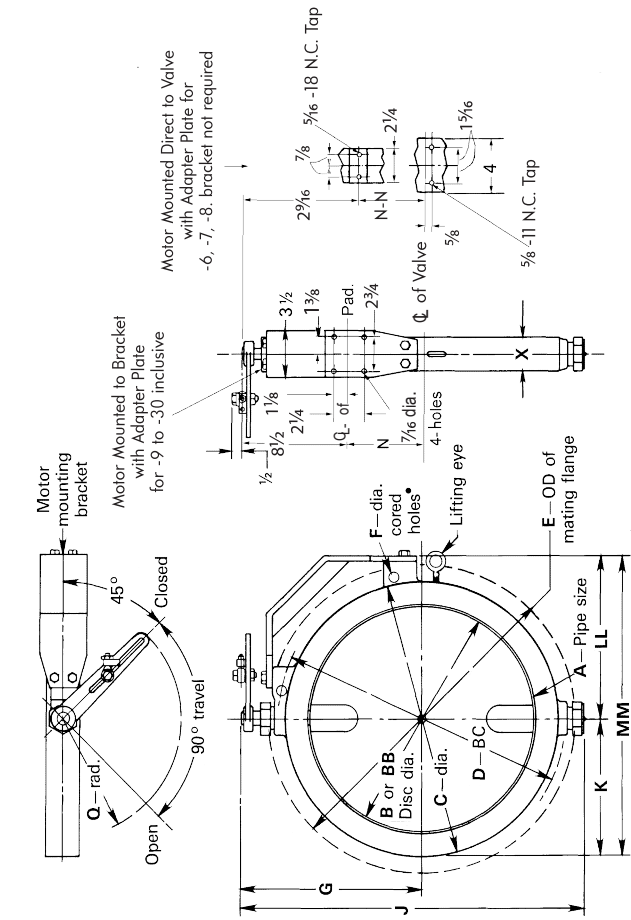
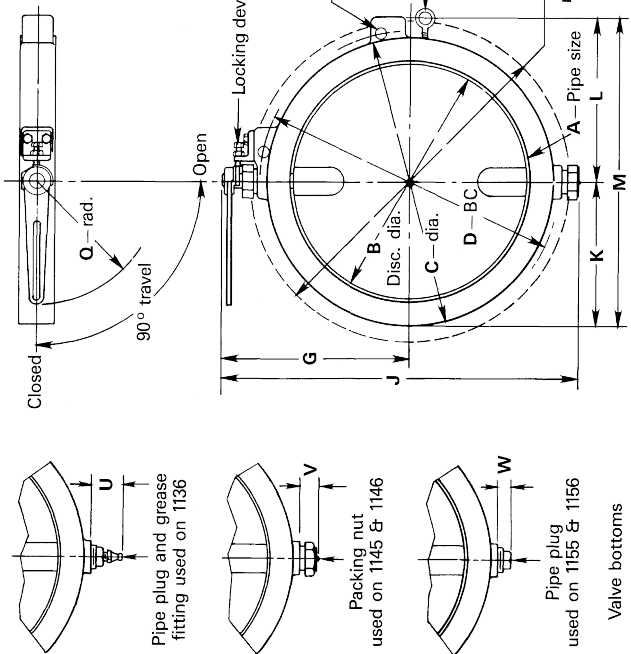

Manually operated
1145 for hot air. 1155 for cold air, gas.

Motor operated
1136A reduced port. 1146 for hot air. 1156 for cold air, gas.

DIMENSIONS SHOWN ARE SUBJECT TO CHANGE. PLEASE OBTAIN CERTIFIED PRINTS FROM FIVES NORTH AMERICAN COMBUSTION, INC.
IF SPACE LIMITATIONS OR OTHER CONSIDERATIONS MAKE EXACT DIMENSIONS CRITICAL.

Valve designation	dimensions in inches																				No. of flange bolts*	To fit flange	Flange bolt dia.		
	A	B*	B†	C	D	E	F*	G	J	K	L	LL	M	MM	N	NN	Q	U	V	W				X	
-6	3	3 1/8	2 7/16	5 1/4	6	7 1/2	3/4	5 1/16	10 9/16	2 5/8	4	4	6 5/8	6 3/8	-	3 1/8	6 5/8	1 3/16	1 3/16	1 1/2	1 1/2	17	ANSI	4	5/8
-7	4	3 7/8	3 1/8	6 3/4	7 1/2	9	3/4	6 3/16	11 11/16	3 3/8	4 5/16	4 5/8	8	8	-	3 3/4	6 5/8	1 3/16	1 3/16	1 1/2	1 1/2	24	ANSI	8	5/8
-8	6	5 3/4	3 7/8	8 5/8	9 1/2	11	7/8	7 1/8	13 5/8▲	4 5/16	5 5/8	5 5/8	9 15/16	9 15/16	-	4 3/4	6 5/8	1 3/16	1 3/16	1 1/2	1 1/2	31	ANSI	8	3/4
-9	8	7 5/8	5 3/4	10 1/2	11 3/4	13 1/2	1	9 15/16	17 13/16■	5 1/4	7 3/4	8 1/2	13	13 3/8	1 5/8	-	8 3/4	1 3/16	1 3/16	1 1/2	1 1/2	55	ANSI	8	3/4
-10	10	9 3/8	7 5/8	13	14 1/4	16	1 1/8	11	20	6 1/2	9 1/8	9 1/2	15 5/8	16	2 3/4	-	8 3/4	1 5/16	1 3/16	1 1/2	1 1/2	65	ANSI	12	7/8
-12	12	11 3/8	9 3/8	15 7/8	17	19	1 1/8	12 1/16	22 1/16	7 15/16	10 1/4	10 5/8	18 3/16	18 9/16	3 5/8	-	8 3/4	1 5/16	1 3/16	1 1/2	1 1/2	95	ANSI	12	7/8
-14	14	13 3/8	11 3/8	17 1/2	18 3/4	21	1 1/4	13	24	8 3/4	10 5/8	11	19 3/8	19 3/4	4 3/4	-	8 3/4	1 5/16	1 3/16	1 1/2	1 1/2	100	ANSI	12	1
-16	16	15 1/8	-	18 5/8	19 1/4	21 1/4	7/8	13 1/8	24 1/4	9 3/16	10 5/8	11	19 13/16	20 3/16	4 7/8	-	8 3/4	-	1 3/16	1 1/2	1 1/2	95	RPM	16	5/8
-18	18	16 3/4	-	20 3/8	21 1/4	23 1/4	7/8	14 1/16	26	10 3/16	11 5/8	12	21 13/16	22 3/16	5 11/16	-	8 3/4	-	1 3/16	1 1/2	1 1/2	110	RPM	16	5/8
-20	20	18 3/4	-	22 1/4	23 3/8	25 1/4	7/8	16	30	11 1/8	12 5/8	13	23 3/4	24 1/8	7 3/4	-	8 3/4	-	1 3/16	1 1/2	1 1/2	130	RPM	20	5/8
-22	22	20 3/4	-	25 1/4	26	28 1/4	7/8	17	32	12 9/16	14	14 3/8	26 9/16	26 15/16	8 3/4	-	8 3/4	-	1 3/16	1 1/2	1 1/2	140	RPM	20	5/8
-24*	24	22 3/4	-	26 7/8	27 3/4	30	7/8	18	34	13 7/16	15	15 3/8	28 7/16	28 13/16	9 3/4	-	8 3/4	-	1 3/16	1 1/2	1 1/2	155	RPM	20	5/8
-30*	30	27 3/4	-	32 3/4	33 3/4	36	1	21 1/16	40 9/16	16 3/8	18	18 1/2	34 3/8	34 7/8	13 1/2	-	8 7/8	-	1 5/16	3/4	3	300	RPM	28	3/4

* OBSOLETE - See Sheet 1146/1156-3

† All, except 1136A.

▲ J = 12 7/16 for 1136A-8.

■ J = 16 1/16 for 1136A-9.

RPM = Rivet Pipe Manufacturers' flange sizes.

• Cored holes for flange bolts straddle centerline.

CONTACT

Fives North American Combustion, Inc.

4455 East 71st Street
Cleveland, OH 44105 - USA
T +1 800 626 3477
F +1 216 373 4237

Fives North American Combustion, Inc.
contact: fna.sales@fivesgroup.com
www.fivesgroup.com





fives

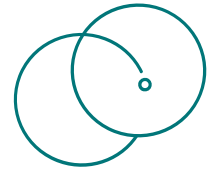

PROCESS
TECHNOLOGIES

ENERGY | COMBUSTION

North American 1145 and 1155 Wafer Valves with Low Fire Switches

Sheet 1145-1
Ref: Bulletin 1136-1156

DIMENSIONS AND ASSEMBLY OF 1145 AND 1155-6 THROUGH -8 VALVES WITH LOW FIRE SWITCH

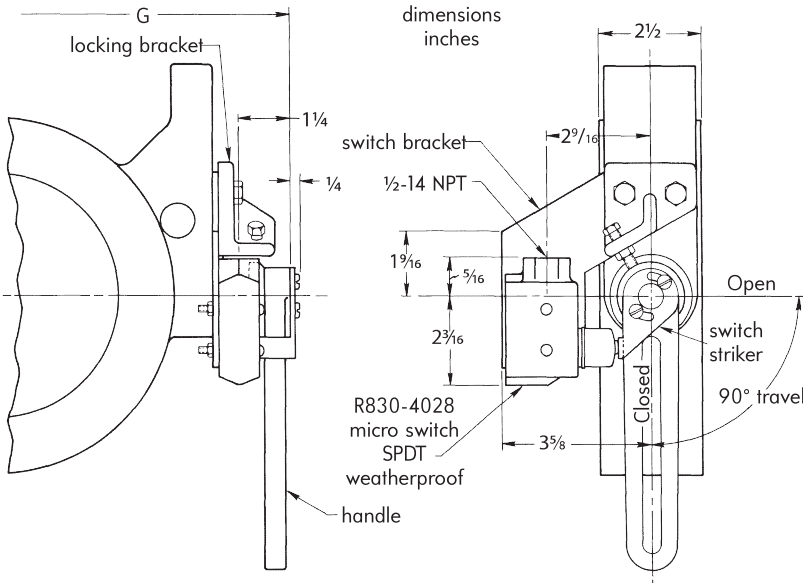

North American offers, as an Engineering special, any size 1145 or 1155 Manual Wafer Valve with low fire switch assembled. Add-on cost for the switch is a constant regardless of valve size. Dimensions and assembly are shown below for all valve sizes (refer to Bulletin 1136-56 for valve dimensions).

This special is ordered by giving valve designation along with corresponding assembly number, which is 2-6432-1 for valve sizes -6 through -8, and 2-6433-1 for valve sizes -9 through -24.

Examples: Special 1155-8 Valve complete with low fire switch per assembly 2-6432-1
Special 1145-20 Valve complete with low fire switch per assembly 2-6433-1

DIMENSIONS AND ASSEMBLY OF 1145 AND 1155-9 THROUGH -24 VALVES WITH LOW FIRE SWITCH

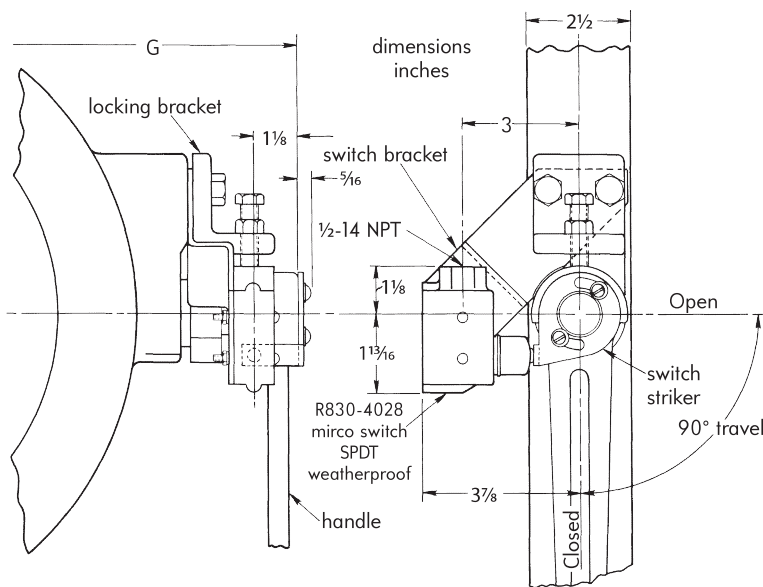

DIMENSIONS SHOWN ARE SUBJECT TO CHANGE. PLEASE OBTAIN CERTIFIED PRINTS FROM FIVES NORTH AMERICAN COMBUSTION, INC. IF SPACE LIMITATIONS OR OTHER CONSIDERATIONS MAKE EXACT DIMENSION(S) CRITICAL.

WARNING: Situations dangerous to personnel and property may exist with the operation and maintenance of any combustion equipment. The presence of fuels, oxidants, hot and cold combustion products, hot surfaces, electrical power in control and ignition circuits, etc., are inherent with any combustion application. Components in combustion systems may exceed 160°F (71°C) surface temperatures and present hot surface contact hazard. Fives North American Combustion, Inc. suggests the use of combustion systems that are in compliance with all Safety Codes, Standards, Regulations and Directives; and care in operation.

CONTACT

fna.sales@fivesgroup.com
T +1 800 626 3477 - F +1 216 373 4237

Fives North American Combustion, Inc.
4455 East 71st Street - Cleveland, OH 44105 - USA
www.fivesgroup.com



fives
Industry can do it

North American 1146 and 1156 Wafer Valves Torque Requirements

Sheet 1146-2

Maximum Torque Requirements Inch-Pounds

1146,1156 Valve Size		Upstream Pressure, psi							
		4	8	12	16	24	32	40	
-6	3"	70	70	70	70	70	70	70	
-7	4"	70	70	70	70	70	80	80	
-8	6"	70	70	80	80	90	100	100	
-9	8"	70	80	90	90	110	120	130	
-10	10"	80	90	100	110	130	150	170	
-12	12"	80	100	110	130	160	200	230	
-14	14"	90	110	140	150	200	240	280	
-16	16"	90	120	150	180	240	300	350	
-18	18"	100	140	180	210	290	360	430	
-20	20"	110	160	200	250	340	434	536	
-22	22"	130	180	230	290	405	530	656	
-24	24"	140	200	260	335	486	637	788	
DISCONTINUED	-30	30"	221	362	502	642	923	1204	1484
	-36	36"	597	924	1252	1579	2235	2890	3545
	-42	42"	806	1262	1717	2173	3083	3994	4905

DRIVE MOTOR SELECTION PROCEDURE

Select wafer valve size based on required flow and allowable pressure drop in system.

Read maximum torque required to drive valve at air pressure to be used. Select drive motor having at least this much torque.

NOTES

Table lists maximum torque required, which is a minimum for drive motor selection. Maximum torque occurs during opening, but may occur at different degrees of opening with different pressures and valve sizes.

Torque table is based on tests conducted with North American "code flow" burners (40-50 fps cold air velocity). Code assumes about one-sixth of the total pressure available is spent in pipe loss, another sixth in control valve drop, and the remainder in metering and burner orifices.

Table can be used for valves supplying single or multiple burners if pipe is properly sized. North American cannot supply torque data for higher velocities.

WARNING: Situations dangerous to personnel and property may exist with the operation and maintenance of any combustion equipment. The presence of fuels, oxidants, hot and cold combustion products, hot surfaces, electrical power in control and ignition circuits, etc., are inherent with any combustion application. Components in combustion systems may exceed 160°F (71°C) surface temperatures and present hot surface contact hazard. Fives North American Combustion, Inc. suggests the use of combustion systems that are in compliance with all Safety Codes, Standards, Regulations and Directives; and care in operation.

CONTACT

fna.sales@fivesgroup.com

T +1 800 626 3477 - F +1 216 373 4237

Fives North American Combustion, Inc.
4455 East 71st Street - Cleveland, OH 44105 - USA
www.fivesgroup.com

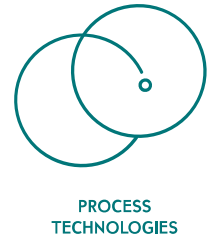

North American Resilient Seat Wafer Valves



1154A Resilient Seat Wafer Valves

- Cast-in actuator flange is universally designed in accordance with ISO 5211 standard dimensions.
- Bi-directional stem seal suitable for pressure or vacuum.
- Stem seal and seat provide total isolation of body and stem parts from stream.