

Control unit for system leakage tests

Type VPM-VC (Valve Check)

DUNGS®
Combustion Controls

8.22



Description

The VPM-VC valve test module checks the tightness of burner gas shut-off valves in combination with one or two pressure switches. The test is performed in accordance with EN 1643.

The program sequence, filling and venting parameters as well as program times can be adjusted by the user according to the system requirements.

Application

The VPM-VC has been designed for automatic leak testing between two solenoid valves in gas-consuming devices, either prior to start-up or after switching off the system. The test system can be used as a single leakage tester or in combination with

automatic burners. It is used in gas burner systems for heating, process heating, process industry and gas engines.

Approvals

- EU type testing certificate as per:
- EU-Gas Appliances Regulation
 - EU-Pressure Equipment Directive

The VPM meets the requirements of:

- Machinery Directive 2006/42/EC
- Low Voltage Directive 2014/35/EU
- EMV 2014/30/EU









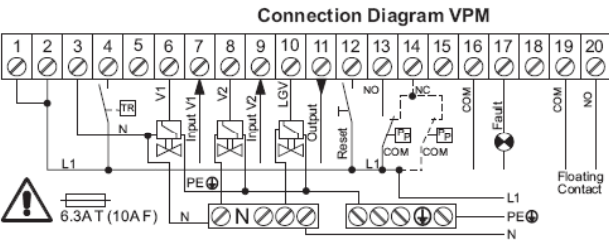

Approvals in other important gas-consuming countries.
FM Approvals Class 7610



VPM-VC Control unit for system leakage tests according to En 1643.
 Checks tightness of the gas burner shut-off valves either before burner start or after shutdown.
 Equipment: One or two gas pressure switches.
 Additional pilot valves are required depending on the system.

Pressure switches/valves/pilot valves are not part of the scope of delivery!

Technical data

Rated voltage (depending on the model)	~ (AC) 230 V +10 % / -15 % 50-60 Hz ±5 % ~ (AC) 115 V +10 % / -15 % 50-60 Hz ±5 %
Power consumption	max. 10 W
Power consumption Typical	115 V: standby 2.6 W operation 4.6 W 230 V: standby 3.1 W operation 5.4 W
Backup fuse L1	6.3 A T (10 A F), integrated, replaceable
Humidity	DIN 60730-1, no dewing admissible
Type of protection	IP 42
Ambient temperature	-20 °C to +60 °C
Storage temperature	-40 °C to +80 °C
Switch-on duration	100 %
Operational altitude	Suitable for use up to 2000 metres above sea level
Test volume	Unlimited
Medium	Any; gas type depending on pressure switch and valve
Inlet pressure	Any; depending on pressure switch and valve
Multifunction output (MFA)	Number of operating cycles V1 > 100.000 (terminal 19 + 20, potential-free) Further settings possible via VisionBox + parameter change: <ol style="list-style-type: none"> 1. Freely selectable number of operating cycles up to 6.5 million (standard 100,000) 2. Signal output with freely selectable number of operating cycles of V2, LGV or release 3. Signal output while the test is running or while voltage is applied 4. Signal after successful switch-off
Program sequence can be selected	Three different program sequences can be selected via DIP switches: <ol style="list-style-type: none"> 1. Valve test before burner start 2. Valve test after burner switch-off 3. Test sequence with optimised valve operating cycles after burner switch-off without additional switching cycles. In this case, only one valve will be tested at a time after successful switch-off, --> lower power consumption and increased valve life.
Test times can be set	DIP switches can be used to select predefined test times of V1 and V2, enabling optimal setting in case of different test volumes, inlet pressures and leakage rates. Alternatively, individual test times, even different times for V1 and V2, can be set via VisionBox.
Filling and venting attempts	Depending on the test volume, different combinations can be selected using DIP switches.
Signalling for V1 and V2	Red/green LEDs signal various information on the program and release states or error codes.
TWI interface	Plug-in connection for DUNGS VisionBox. The VisionBox can be used to access the VPM via a PC. The VisionBox is hardware and software for VPM parameter setting. Status information and error error memory data can be read out.
Mounting position	As desired

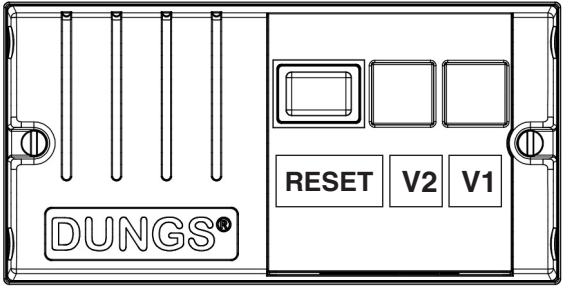
Wiring scheme	⊘ Outputs		Electrical data
<p style="text-align: center;">Connection Diagram VPM</p>  <p>The sum of the currents of all safety-related consumers must not exceed 5 A! The sum of the currents of all consumers must not exceed 6.3 A (10 A).</p>	11		Release 115/230 VAC / 5 A cos φ = 1 Minimum load 0.5 W
	6		V1 115/230 VAC / 2 A cos φ = 1 Minimum load 0.5 W
	8		V2 115/230 VAC / 2 A cos φ = 1 Minimum load 0.5 W
	10		LGV 115/230 VAC / 2 A cos φ = 1 Minimum load 0.5 W
	16 17		External fault 115/230 VAC / 1 A cos φ = 1
	19 20		MFA 115/230 VAC / 1 A cos φ = 1
	⊘ Inputs		Electrical data
	4	TR	Test request 115/230 VAC
	13		Pp ₍₂₎ 115/230 VAC (NO)
	14		Pp ₍₁₎ 115/230 VAC (NC)
12		Remote unlocking 115/230 VAC	
7		V1_In 115/230 VAC	
9		V2_In 115/230 VAC	

Signalling unit		Error information				
				Detailed error information via flash codes		
				All LEDs are flashing: <ul style="list-style-type: none"> when a key press is requested during a level change when the VPM is ready for extended unlocking 		
MFT (RESET) = multifunction switch: Unlocking switch for error status ...max. 5x/15 min. Changeover switch to switch to the password-protected function level for service and OEM parameter setting via TWI interface by means of the VisionBox.	V2 two LEDs green / red	V1 two LEDs green / red	Off	Constantly red	V1 leaking	
			Constantly red	Off	V2 leaking	
			Red flashing 1x	Red flashing 1x	Venting error	
	Red flashing 2x	Red flashing 2x	Filling error			
	Switch-on (mains): All LEDs light up as a functional test for approx. 1.5 s.	Waiting for test request: Green LED's flashing slowly (4 s off, 0,125 s on). Depending on the states, the LED-V1 and LED-V2 indicators are flashing or lit constantly		Red flashing 3x	Red flashing 3x	Wrong position of DIP switch
				Red flashing 4x	Red flashing 4x	Unlock failed
				Red flashing 5x	Red flashing 5x	Power at V1.In or V2.In before test sequence completed
				Constantly red	Constantly red	...all other errors
	Constantly green	Constantly green	Release signal			

Modification of the program sequence by an application-specific setting of the B/C DIP switches

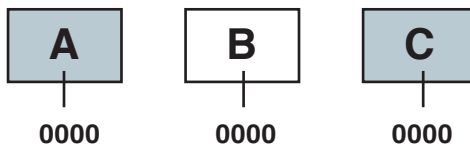
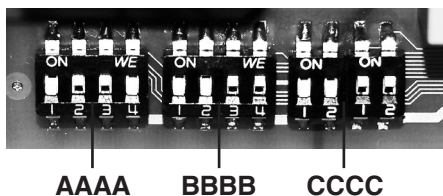

A Test sequence		B t_{test} V1, V2 test time		C Number of venting or filling attempts	
1100	Test during the start phase before burner ignition	1100	10 s	1100	Venting 10 (1) Filling 1
		0110	22 s	0110	Venting 1 Filling 1
		1001	30 s	1001	Venting 1 Filling 10
1001	Test after regular shutdown	0011	55 s Changeable via software t_{test} : P22 for test time V1 P23 for test time V2 If this switch position is used, parameter setting should be checked via the VisionBox.	0011	Venting 3 (1) Filling 3 (1) The following can be changed via the software: P32: Number of venting operations P31: Number of filling operations If this switch position is used, parameter setting should be checked via the VisionBox.
0011	Test after regular shutdown in reduced mode without additional operating cycles Operating mode "T- Down optimised": after regular switch-off, one valve is tested at a time alternatively, the other valve is kept open. The change takes place after the next removal of the test request during release. - burner with frequent starts - longer valve life - reduced power consumption		For the calculation of the test times, see declaration of conformity VPM-VC Setting must be higher than the calculated time. $t_{DIP} > t_{test V1}, t_{test V2}$	(1) 	For more detailed explanations, see installation examples in the declaration of conformity VPM-VC. According to EN1643, 1 filling or 1 emptying attempt for max. 3 s into the burner chamber is admissible (DUNGS as-delivered configuration). At filling and emptying times of 1 s of the gas main valves, max. 3 attempts are admissible. If the number of venting attempts is higher, venting must be into a safe area (LGV vent valve).

Installation examples	
	The functional principle must be selected in accordance with the local regulations
	Prevent soiling by using appropriate gas filters
	Use of pilot valves recommended

Please note: Switch positions (1), (2), (3), (4)							
(1)	According to EN1643, 1 filling or 1 emptying attempt for max. 3 s into the burner chamber is admissible (DUNGS as-delivered configuration). At filling and emptying times of 1 s of the gas main valves, max. 3 attempts are admissible.	(2)	In the case of filling or emptying tests via auxiliary valves, it follows from (1) that in the case of auxiliary valves which can only achieve a maximum of 1/10th of the maximum gas flow rate of the main valves, the specifications of EN1643 are also fulfilled with 10 filling or emptying tests.	(3)	If the valve check is carried out after a regular shutdown, the system setup must ensure that locking the system prevents a valve check during a fault situation. This can only be achieved by safe interruption of the power supply to the VPM when a fault occurs.	(4)	If this switch position is used, parameter setting should be checked via the VisionBox.

1a Direct valve check via LGV, venting through roof		
--- Valve check system component: VPM-VC, Pp, LGV		
		DIP-mode: A: 1100 1001 (3) 0011 (3), (4) B: xxxx C: 1100 0110 0011 (1), (4) Parameter: ---
1b Direct valve check via V4, venting into the burner chamber		
--- Valve check system component: VPM-VC, Pp, V4		
		DIP-mode: A: 1100 1001 (3) 0011 (3), (4) B: xxxx C: 1100 (2) 0110 0011 (1), (4) Parameter: ---

Notes regarding 1a, 2:

If a valve closed when not powered is replaced instead of a LGV (open when not powered), it must be connected to output V2 (terminal 8).

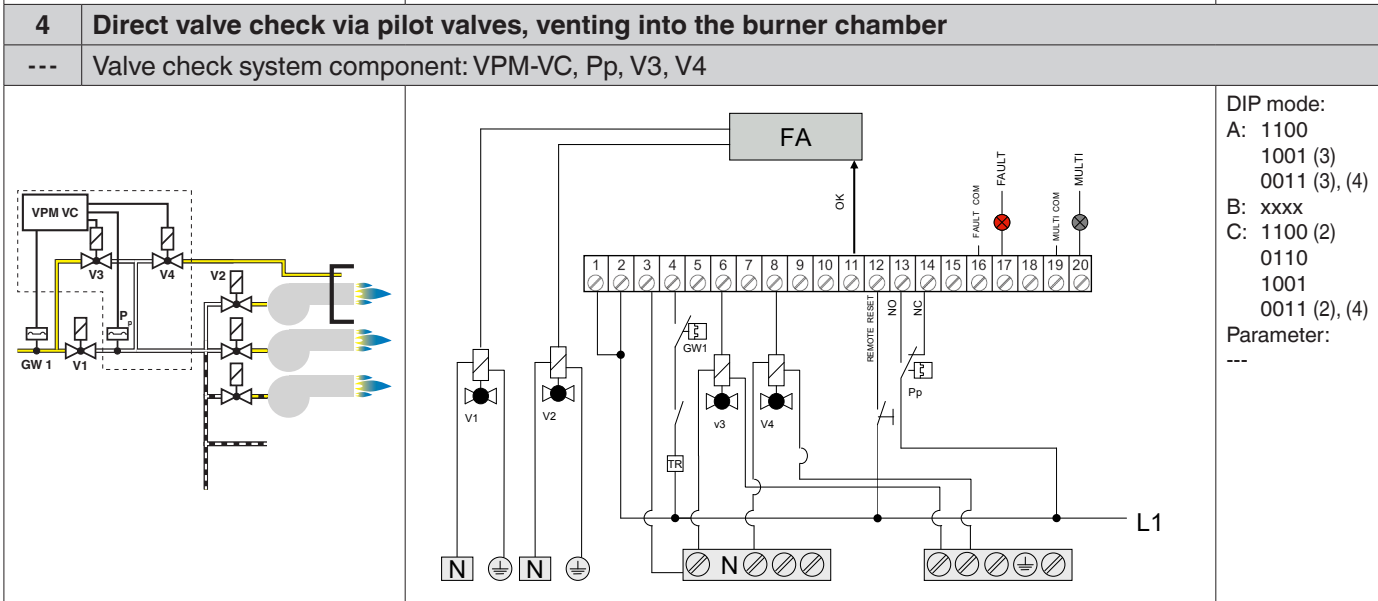
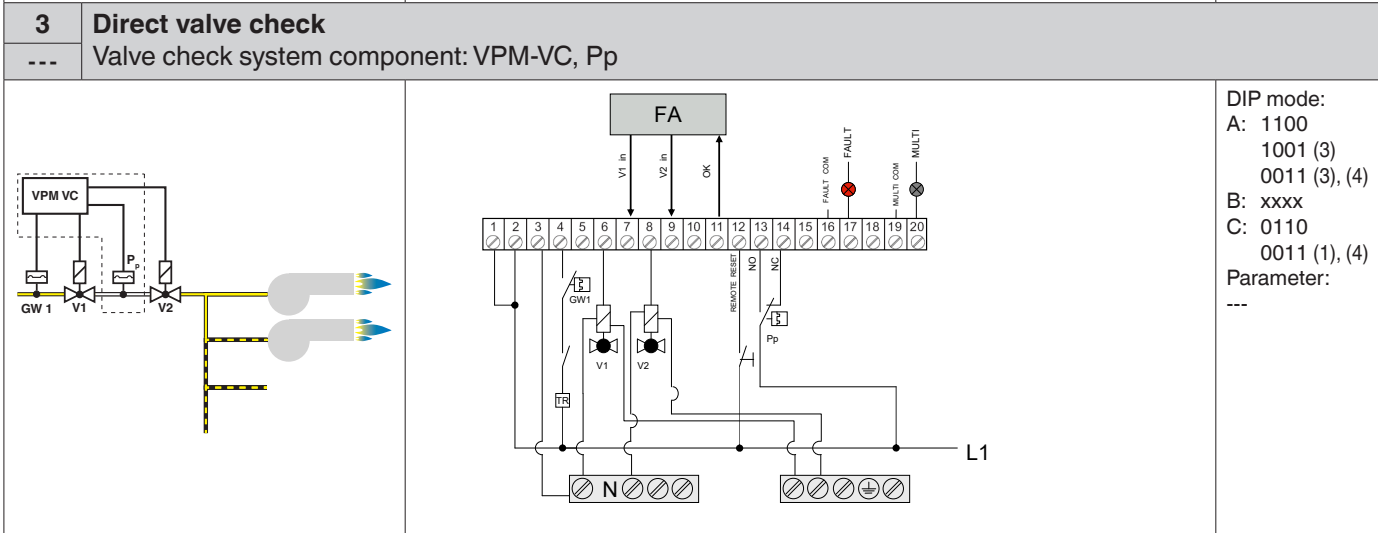
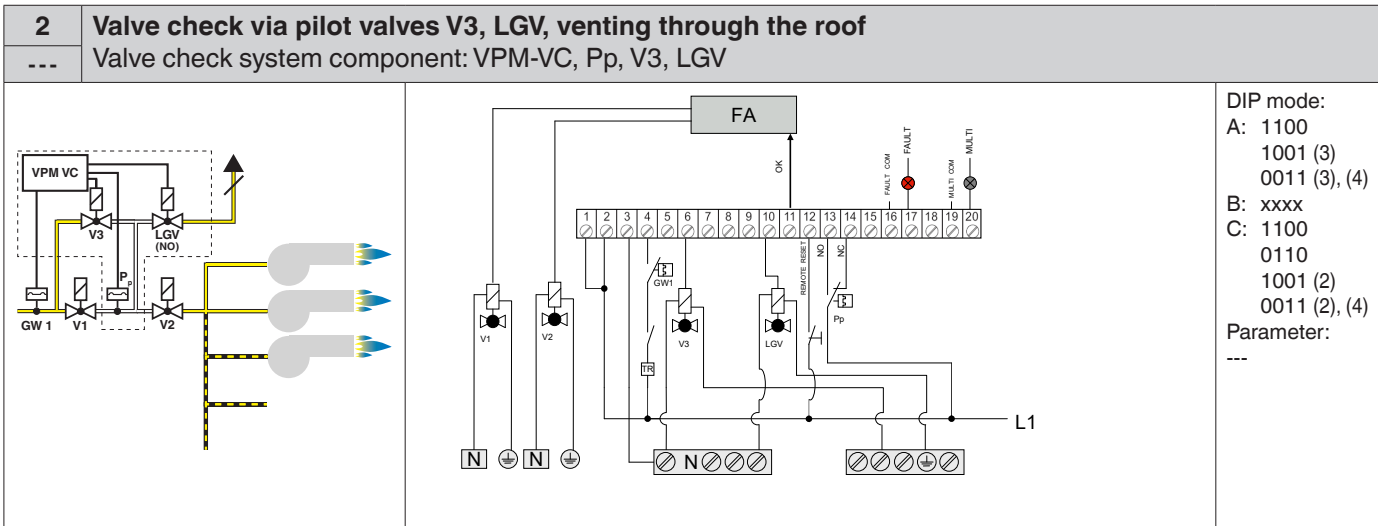

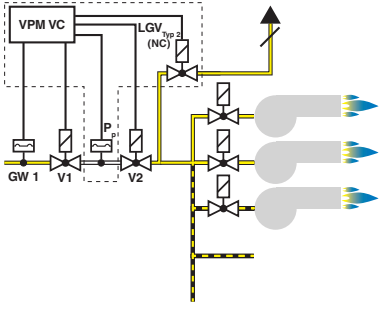
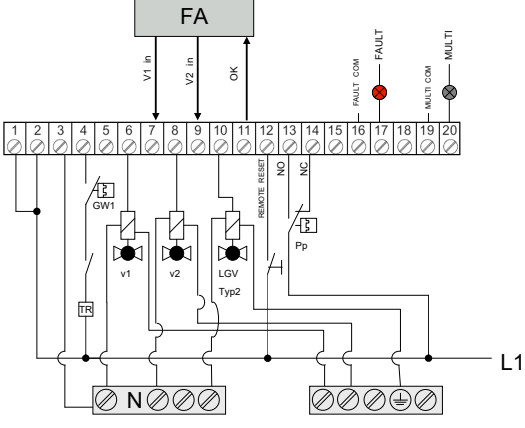
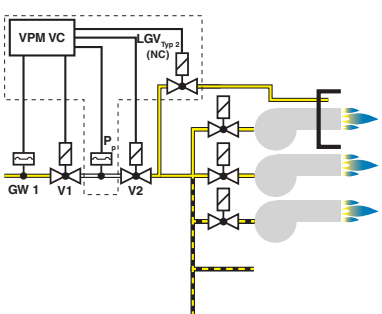
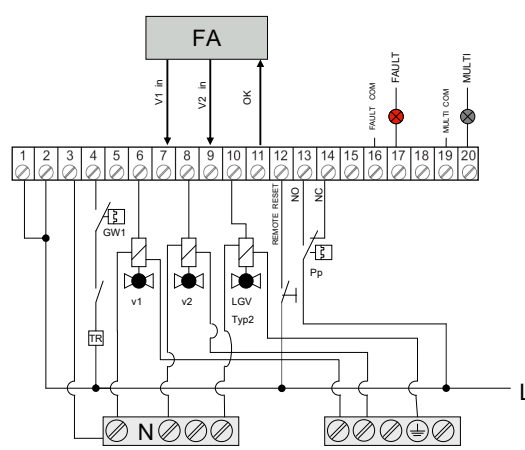
<p>5a</p> <p>---</p>	<p>Valve check via pilot valves, venting to V2 via LGV^{type2 (normally closed)}</p> <p>Valve check system component: VPM-VC, Pp, LGV_{Type2} (NC)</p> <p>The LGV type 2 is required for opening the gas flow behind V2 (to the burner chamber or atmosphere), allowing it to be emptied when V2 is deliberately (during the test) open. The pressure behind V2 must be able to escape, since otherwise V2, as response to "No gas pressure", allows gas to pass in the reverse direction during the test time, if there is still pressure behind V2. This allows the pressure to drop in the monitored inter-space if V2 is leaking. During release (automatic burner control is working), the LGV type 2 is closed.</p>	<p>DIP mode: A: 1100 1001 (3) 0011 (3), (4) B: xxxx C: 1100 0110 0011 (1), (4) Parameter: P12 = 1</p>
		<p>DIP mode: A: 1100 1001 (3) 0011 (3), (4) B: xxxx C: 1100 0110 0011 (1), (4) Parameter: P12 = 1</p>
<p>5b</p> <p>---</p>	<p>Valve check via pilot valves, venting to V2 via LGV^{type2 (normally closed)} into the burner chamber</p> <p>Valve check system component: VPM-VC, Pp, LGV_{Type 2} (NC)</p>	<p>DIP mode: A: 1100 1001 (3) 0011 (3), (4) B: xxxx C: 1100 0110 0011 (1), (4) Parameter: P12 = 1</p>
		<p>DIP mode: A: 1100 1001 (3) 0011 (3), (4) B: xxxx C: 1100 0110 0011 (1), (4) Parameter: P12 = 1</p>

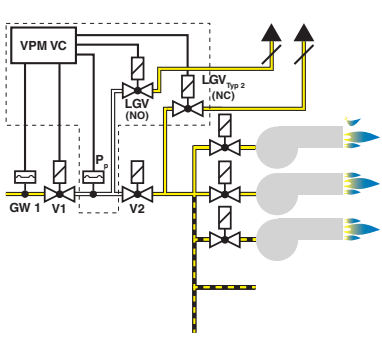
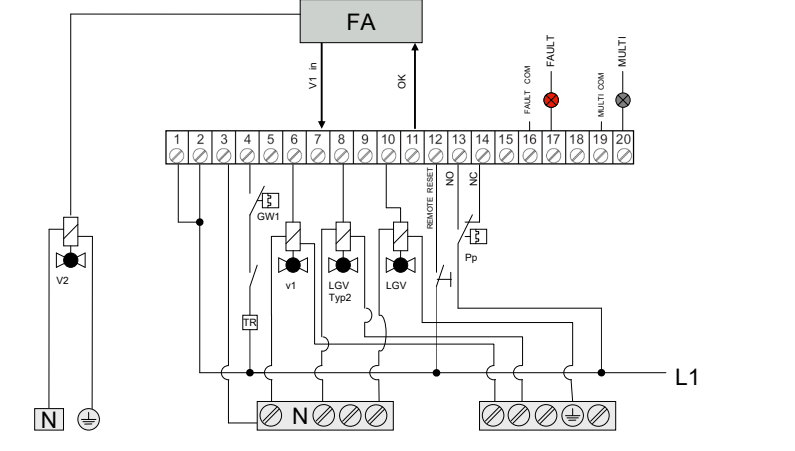

6a	Valve check via pilot valves and LGV, venting to V2 via LGV_{type2} (normally closed) Venting through roof Valve check system component: VPM-VC, Pp, LGV, LGV _{type2} (NC)	
---	The LGV type2 is required for opening the gas flow behind V2 (to the burner chamber or atmosphere). This allows the pressure to drop in the monitored interspace if V2 is leaking. Emptying takes place via LGV. During release (automatic burner control is working), the LGV and the LGV-type 2 are closed.	
		DIP mode: A: 1100 1001 (3) 0011 (3), (4) B: xxxx C: 1100 0110 0011 (1), (4) Parameter: P11 = 1

For further configuration options and connection diagrams, see Declaration of Conformity # 259960



Control unit for system leakage tests

**Type VPM-VC
(Valve Check)**

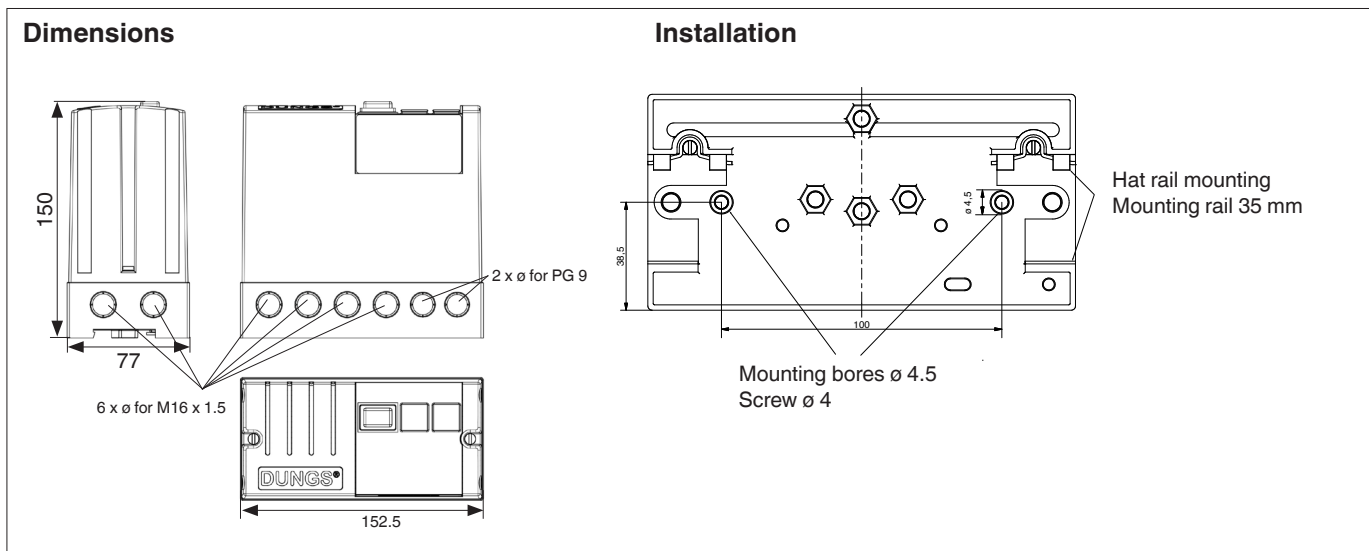

Version	Description	Order No.
Complete device 	VPM-VC cpl. 230 VAC	259 696
	VPM-VC cpl. 115 VAC	259 697
Base 	1 piece	259 694



Accessories	
	<p>Gas pressure switch Depending on the operating pressure, see data sheets LGW...A4 (5.08) GW...A4 HP (5.04) GW...A5 (5.02) GW...A6 (5.01) / GW...A5 (5.02) flange mounting</p>
	<p>Pilot solenoid valves see data sheets DMV... (7.30, 7.37, 7.38), MV 502 (6.21) MVD ... (6.20)</p>
	<p>MPA VisionBox As addition to MPA parameterisation and service box for setting VPM parameters via a PC/laptop.</p>

Subject to technical modification in the interest of technical progress.

Company address
Karl Dungs GmbH & Co. KG
Karl-Dungs-Platz 1
D-73660 Urbach, Germany
Phone +49 7181-804-0
Fax +49 7181-804-166

Postal address
Karl Dungs GmbH & Co. KG
Postfach 12 29
D-73602 Schorndorf, Germany
e-mail: info@dungs.com
Internet: www.dungs.com