

**D****GB****F****I****DUNGS**<sup>®</sup>  
Combustion Controls

<b>Konformitäts- erklärung</b>	<b>Declaration of conformity</b>	<b>Déclaration de conformité</b>	<b>Dichiarazione di conformità</b>
<b>Gebrauchs- anleitung</b>	<b>Instructions</b>	<b>Notice d'utilisation</b>	<b>Istruzioni di esercizio e di montaggio</b>
<b>GW...A4, GW...A4/2</b>			
<b>Gas- und Luft- druckwächter</b>	<b>Gas and air pressure switch</b>	<b>Pressostat pour gaz et air</b>	<b>Pressostato per gas e aria</b>



**GW...A4, GW...A4/2**  
**# 255 963**



## EU-Konformitäts- erklärung

## EU Declaration of conformity

## Déclaration de conformité UE

## Dichiarazione di conformità UE

<b>Produkt / Product Produit / Prodotto</b>	<b>GW...A4, GW...A4/2</b>		<b>Gas- und Luftdruckwächter Gas and air pressure switch Pressostat pour gaz et air Pressostato per gas e aria</b>
<b>Hersteller / Manufacturer Fabricant / Produttore</b>	<b>Karl Dungs GmbH &amp; Co. KG · Karl-Dungs-Platz 1 · D-73660 Urbach/Germany</b>		
<p>bescheinigt hiermit, dass die in dieser Übersicht genannten Produkte einer <b>EU-Baumusterprüfung (Baumuster)</b> unterzogen wurden und die wesentlichen Sicherheitsanforderungen der:</p> <ul style="list-style-type: none"> <li>• <b>EU-Gasgeräteverordnung (EU) 2016/426</b></li> <li>• <b>EU-Druckgeräterichtlinie 2014/68/EU</b></li> <li>• <b>Niederspannungsrichtlinie 2014/35/EU</b></li> </ul> <p>in der gültigen Fassung erfüllen.</p> <p>Alle nach Druckgeräterichtlinie zugelassenen Komponenten sind Ausrüstungsteile mit Sicherheitsfunktion. Bei einer von uns nicht freigegebenen Änderung des Gerätes verliert diese Erklärung ihre Gültigkeit. Der oben beschriebene Gegenstand der Erklärung entspricht den einschlägigen Harmonisierungsrechtsvorschriften der Union. Die alleinige Verantwortung für die Ausstellung dieser Konformitätserklärung trägt der Hersteller.</p>	<p>certifies herewith that the products named in this overview were subjected to an <b>EU-Type Examination (production type)</b> and meet the essential safety requirements:</p> <ul style="list-style-type: none"> <li>• <b>EU-Gas Appliances Regulation (EU) 2016/426</b></li> <li>• <b>EU-Pressure Equipment Directive "2014/68/EU"</b></li> <li>• <b>Low-Voltage Directive "2014/35/EU"</b></li> </ul> <p>as amended.</p> <p>All of the components certified according to the Pressure Equipment Directive are equipment parts with safety function. In the event of an alteration of the equipment not approved by us this declaration loses its validity. The object of the declaration described above conforms with the relevant Union harmonisation legislation. This declaration of conformity is issued under the sole responsibility of the manufacturer.</p>	<p>certifie par la présente que le produit mentionné dans cette vue d'ensemble a été soumis à un <b>examen UE de type (type de fabrication)</b> et qu'il est conforme aux exigences en matières de sécurité des dernières versions en vigueur de :</p> <ul style="list-style-type: none"> <li>• <b>Règlement européen sur les appareils brûlant des combustibles gazeux (UE) 2016/426</b></li> <li>• <b>Directive européenne relative aux appareils sous pression 2014/68/UE</b></li> <li>• <b>Directive basse tension 2014/35/UE</b></li> </ul> <p>Tous les composants homologués conformément à la directive sur les dispositifs sous pression sont des éléments d'équipement à fonction de sécurité. Ce communiqué n'est plus valable si nous effectuons une modification libre de l'appareil. L'objet décrit ci-dessus de la présente déclaration correspond aux prescriptions légales applicables en matière d'harmonisation de l'Union. Le fabricant porte l'entière responsabilité pour l'établissement de la présente déclaration de conformité.</p>	<p>Con la presente si certifica che i prodotti citati in questa panoramica sono stati sottoposti a una prova di <b>esame UE del tipo (tipo di produzione)</b> e che i requisiti di sicurezza essenziali:</p> <ul style="list-style-type: none"> <li>• <b>Regolamento UE sugli apparecchi a gas (UE) 2016/426</b></li> <li>• <b>Direttiva UE sulle attrezzature a pressione 2014/68/UE</b></li> <li>• <b>Direttiva sulla bassa tensione 2014/35/UE</b></li> </ul> <p>sono soddisfatti nella versione valida.</p> <p>Tutti i componenti approvati secondo la direttiva sulle apparecchiature a pressione sono parti di apparecchiature con funzione di sicurezza. In caso di modifica dell'apparecchio non ammessa, questa dichiarazione perde di validità. L'oggetto della dichiarazione di cui sopra descritta è conforme alla pertinente normativa di armonizzazione dell'Unione. La presente dichiarazione di conformità è rilasciata sotto la responsabilità esclusiva del fabbricante.</p>
<b>Prüfgrundlage der EU-Baumusterprüfung (Baumuster) Specified requirements of the EU-Type Examination (production type) Base d'essai de l'examen UE de type (type de fabrication) Criteri di prova dell'omologazione esame UE del tipo (tipo di produzione)</b>	<b>EN 1854 EN 13611 ISO 23550</b>		
<b>Gültigkeitsdauer / Bescheinigung Term of validity / attestation Validité / certificat Durata della validità / Attestazione</b>	<b>2033-10-11 CE0036</b>	<b>2028-02-27 CE-0123CT1089</b>	
<b>Notifizierte Stelle Notified Body Organisme notifié Organismo notificato</b>	<b>2014/68/EU TÜV SÜD Industrie Service GmbH Westendstraße 199 D-80686 München Germany Notified Body number: 0036</b>	<b>(EU) 2016/426 TÜV SÜD Product Service GmbH Zertifizierstellen Ridlerstraße 65 D-80339 München, Germany Notified Body number: 0123</b>	
<b>Überwachung des QS-Systems Monitoring of the QA system Contrôle du système d'assurance qualité Monitoraggio del sistema QS</b>	<b>Gewähltes Konformitätsverfahren Modul B+D Conformity process adopted: Module B+D Procédure de conformité sélectionnée : module B+D Procedura di conformità selezionata: modulo B+D</b>		
<b>B.Sc., MBA Simon P. Dungs, Geschäftsführer / Chief Operating Officer / Directeur / Amministratore Urbach, 2023-11-08</b>			

**Declaration of Conformity**

<b>Product</b>	<b>GW...A4, GW...A4/2</b>	<b>Gas and air pressure switch</b>
<b>Manufacturer</b>	<b>Karl Dungs GmbH &amp; Co. KG · Karl-Dungs-Platz 1 · D-73660 Urbach/Germany</b>	
<p>Certifies herewith that the products named in this overview were subjected to a <b>Type Examination (production type)</b> and meet the essential safety requirements:</p> <ul style="list-style-type: none"> <li>• <b>Gas Appliances (Enforcement) and Miscellaneous Amendment Regulations, UKSI 2018:389 (as amended by UKSI 2019:696)</b></li> <li>• <b>The Pressure Equipment Safety Regulations, UKSI 2016:1105 (as amended by UKSI 2019: 969)</b></li> <li>• <b>The Electrical Equipment (Safety) Regulations 2016, UKSI 2016: 1101 as amended</b></li> </ul> <p>All of the components certified according to the Pressure Equipment (Safety) Regulations 2016 are equipment parts with safety function. In the event of an alteration of the equipment not approved by us this declaration loses its validity. The object of the declaration described above conforms with the relevant legislation. This declaration of conformity is issued under the sole responsibility of the manufacturer.</p>		
<b>Specified requirements of the Type Examination (production type)</b>	<b>EN 1854 EN 13611</b>	
<b>Term of validity</b>	<b>2032-08-09</b>	<b>2032-08-11</b>
<b>Approved Bodies</b>	<b>2016 No. 1105</b> <b>TUV SUD BABT Unlimited</b> Octagon House, Concorde Way, Segensworth North, Fareham, Hampshire, PO15 5RL, United Kingdom Approved Body Number: 0168	<b>2018 No. 389</b> <b>TUV SUD BABT Unlimited</b> Octagon House, Concorde Way, Segensworth North, Fareham, Hampshire, PO15 5RL, United Kingdom Approved Body Number: 0168
<b>Monitoring of the QA system</b>	Conformity process adopted: Module B+D	
B.Sc., MBA Simon P. Dungs, Chief Operating Officer Urbach, 2022-08-23		



**Betriebs- und Montageanleitung**

**Operation and assembly instructions**

**Notice d'emploi et de montage**

**Istruzioni di esercizio e di montaggio**

Gas- und Luftdruckwächter  
GW...A4, GW...A4/2

Gas and air pressure switch  
GW...A4, GW...A4/2

Pressostat pour gaz et air  
GW...A4, GW...A4/2

Pressostato per gas e aria  
GW...A4, GW...A4/2

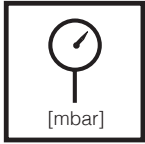

Max. Betriebsdruck / Max. operating pressure/ Pression de service maxi. Max. pressione di esercizio  
GW 500 A4  $p_{max.} = 600 \text{ mbar (60 kPa)}$

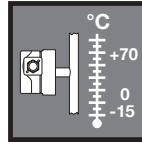

Umgebungstemperatur  
Ambient temperature  
Température ambiante  
Temperatura ambiente  
-15 °C ... +70 °C

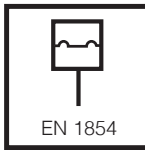

Druckwächter / Pressure Switch/  
Pressostat/Pressostato  
Typ/Type/Type/Tipo  
GW 500 A4  
nach/acc./selon/a norme EN 1854

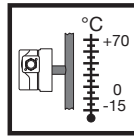

Mediumtemperatur  
Medium temperature  
Température du fluide  
Temperatura fluido  
-15 °C ... +70 °C

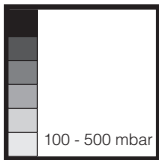

Einstellbereiche  
Setting ranges  
Plages de réglage  
Campi di taratura

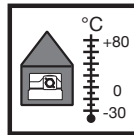

Lagertemperatur  
Storage temperature  
Température de stockage  
Temperatura stoccaggio  
-30 °C ... +80 °C

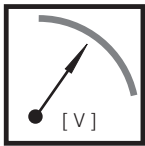

Ag-Kontakt/Ag contact  
Contact Ag/Contatti Ag  
~(AC) eff., min./mini 24 V,  
~(AC) max./maxi. 250 V  
=(DC) min./mini. 24 V,  
=(DC) max./maxi. 48 V  
Au-Kontakt/Au contact  
Contact Au/Contatti Au  
=(DC) min./mini. 5 V,  
=(DC) max./maxi. 24 V

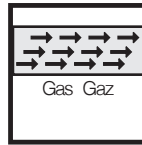

Familie 1 + 2 + 3  
Family 1 + 2 + 3  
Famille 1 + 2 + 3  
Famiglia 1 + 2 + 3

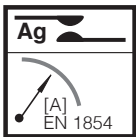

Nennstrom/nominal current/  
courant nominal/corrente nominale ~ (AC) 10 A  
Schaltstrom/current on contact/  
courant de commutation/corrente di intervento  
~(AC) eff., min./mini 20 mA,  
~(AC) max./maxi. 6 A  $\cos \varphi 1$   
~(AC) max./maxi. 3 A  $\cos \varphi 0,6$   
=(DC) min./mini. 20 mA  
=(DC) max./maxi. 1 A



Schutzart / Degree of protection  
Protection / Protezione  
GW...A4  
IP 54 nach / acc. / selon / a norme IEC 529 (EN 60529)  
GW...A4/2  
IP 65 nach / acc. / selon / a norme IEC 529 (EN 60529)

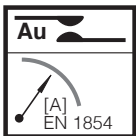

Nennstrom/nominal current/  
courant nominal/corrente nominale  
~(DC) 20 mA  
Schaltstrom/current on contact/  
courant de commutation/corrente di intervento  
=(DC) min./mini. 5 mA  
=(DC) max./maxi. 20 mA

**Einbaulage / Installation position / Position de montage / Posizione de montaggio**

	<p>Standardeinbaulage; bei Abweichung Schaltpunktänderung beachten:                  Standard installation position; in case of deviation, take the switch point change into account:                  Position de montage standard ; en cas de divergence, veiller à la modification du point de commutation.                  Posizione di montaggio standard, per altre posizioni di montaggio osservare il cambiamento del punto di intervento:                  GW 500 A4 ca. ± 10 mbar</p>
	<p>Bei waagrechtem Einbau schaltet der Druckwächter bei einem höheren Druck.                  When installed horizontally, the pressure switch responds if the pressure is higher.                  En position horizontale, le pressostat réagit à une pression supérieure.                  Con montaggio orizzontale il pressostato scatta ad un aumento di pressione.</p>
	<p>Bei Einbau waagrecht über Kopf schaltet der Druckwächter bei einem niedrigeren Druck.                  When installed horizontally in an upside down position, the pressure switch responds if the pressure is lower.                  En position horizontale à l'envers, le pressostat réagit à une pression inférieure.                  Con montaggio orizzontale capovolto il pressostato scatta ad una diminuzione di pressione.</p>
	<p>Bei Einbau in einer Zwischeneinbaulage schaltet der Druckwächter bei einem vom eingestellten Sollwert maximal höheren bzw. niedrigeren Druck.                  When installed at an intermediate position, the pressure switch responds if there is maximum upper or lower pressure deviation w.r.t. the set pressure reference value.                  En position de montage intermédiaire, le pressostat réagit à une pression maximale supérieure ou inférieure à la valeur de consigne réglée.                  Con montaggio in una posizione intermedia il pressostato scatta ad una pressione diversa da quella nominale massima regolata.</p>

**Einbaumaße/Dimensions**  
**Cotes d'encombrement/Dimensioni [mm]**  
**GW...A4**

58,6  
 37,4  
 10,3  
 Meßstutzen, integriert ø 9  
 Measurement nozzle, integrated  
 Prise de pression intégrée  
 presa pressione, integrata

Druckanschluß G 1/4  
 G 1/4 pressure connection  
 Raccordement du fluide G 1/4  
 attacco pressione G 1/4

Druckanschluß G 1/8  
 G 1/8 pressure connection  
 Raccordement du fluide G 1/8  
 attacco pressione G 1/8

76  
 ø 53,75 (LK 76)  
 72  
 SW 21

M 20 x 1,5 oder Steckanschluß  
 für Leitungsdose nach  
 DIN EN 175 301-803  
 M20 x 1,5 or plug-type connection for cable socket according  
 to DIN EN 175 301-803  
 M20 x 1,5 ou fiche pour boîtier suivant DIN EN 175 301-803  
 M20 x 1,5 oppure collegamento a spina per presa di rete a  
 norme DIN EN 175 301-803

4 X Ø 4,2  
 für Schrauben M4 ISO 1201, ISO 4762  
 for M4 ISO 1201, ISO 4762 screws  
 pour vis M4 ISO 1201, ISO 4762  
 per viti M4 ISO 1201, ISO 4762

**Einbaumaße/Dimensions**  
**Cotes d'encombrement/Dimensioni [mm]**  
**GW...A4/2**

37,4  
 10,3  
 68,8  
 Verschlussschraube G 1/4 mit Dichtring  
 Plug for G 1/4 pressure connection  
 Bouchon pour raccord de pression G 1/4  
 Tappo per attacco pressione G 1/4

Verschlussschraube mit Längsschlitz 1,0  
 Screw cap with slot 1,0  
 Bouchon fileté à tête fendue 1,0  
 Vite di chiusura con intaglio longitudinale 1,0

4 selbstfrüchende Zylinderschrauben M3x14 Längsschlitz 0,8 und Kreuzschlitz DIN 7962-Z2  
 4 self-tapping cylinder bolts M3x14 slot 0,8 and cross slot to DIN 7962-Z2  
 4 vis auto-taraudeuses à tête cylindrique M3x14  
 tête fendue 0,8 et empreinte cruciforme DIN 7962-Z 2  
 Quattro viti a testa cilindrica autofilettanti M3 x 14  
 Intaglio longitudinale 0,8 e intaglio a croce DIN 7962-Z 2

ø 77  
 ø 53,75  
 ø 4,2 - 0,2  
 Druckanschluß G 1/8  
 G 1/8 pressure connection  
 Raccord de pression G 1/8  
 Attacco pressione G 1/8

SW 21  
 38,5  
 Druckanschluß G 1/4  
 Gas oder Luft  
 G 1/4 pressure connection  
 gas or air  
 Raccord de pression G 1/4  
 Gaz ou air  
 Attacco pressione G 1/4  
 gas oppure aria

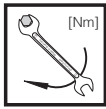

max. Drehmomente / Systemzubehör  
 max. torque / System accessories  
 max. couple / Accessoires du système  
 max. coppie / Accessorio di sistema

$\varnothing$ 3x14	M 3	M 4
1,2 Nm	1,2 Nm	2,5 Nm



**Geeignetes Werkzeug einsetzen!**  
**Please use proper tools!**  
**Utiliser des outils adaptés!**  
**Impiegare gli attrezzi adeguati!**

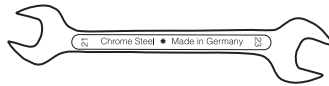

**Gerät darf nicht als Hebel benutzt werden**  
**Do not use unit as lever.**  
**Ne pas utiliser le pressostat comme un levier.**  
**L'apparecchio non deve essere usato come leva.**

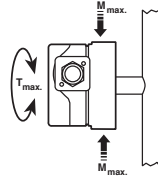

DN	8
Rp	1/4
<b>M<sub>max.</sub></b>	<b>35 [Nm] t ≤ 10 s</b>
<b>T<sub>max.</sub></b>	<b>20 [Nm] t ≤ 10 s</b>

**Einbau**  
 GW...A4, GW...A4/2

1. Der Druckwächter wird direkt auf einen Rohrstützen mit R 1/4 Außengewinde aufgeschraubt. Bild 1.
2. Nach Einbau Dichtheits- und Funktionskontrolle durchführen.

**Installation of**  
 GW...A4, GW...A4/2

1. Screw the pressure switch directly on a tube socket with R 1/4 outer thread (see Fig. 1).
2. After installation, perform a leakage and function test.

**Montage**  
 GW...A4, GW...A4/2

1. Le pressostat peut se visser directement sur un piquage R 1/4" Fig.1.
2. Après le montage contrôler la fonction et l'étanchéité.

**Installazione**  
 GW...A4, GW...A4/2

1. Il pressostato viene avvitato direttamente su un tubo di sostegno con filetto esterno R 1/4 (Fig.1)
2. Dopo il montaggio effettuare i controlli di tenuta e funzionalità.

**⚠ Auf vibrationsfreien Einbau achten! Bild 2.**

**⚠ Ensure that the pressure switch is installed free of vibration! (see Fig. 2).**

**⚠ Veiller à ce que l'appareil ne subisse pas de vibrations! Fig. 2.**

**⚠ Evitare possibilità di vibrazioni! Fig. 2.**

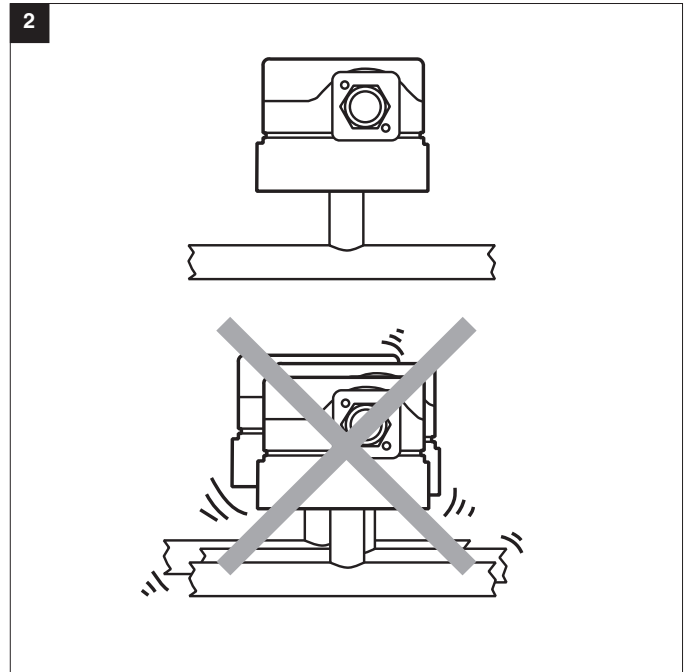
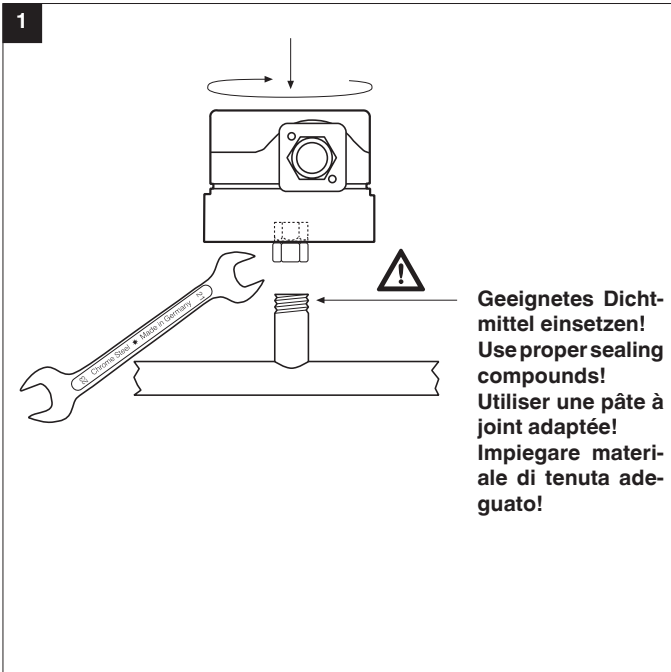

**Elektrischer Anschluß**  
**Electrical connection**  
**Raccordement électrique**  
**Allacciamento elettrico**  
**IEC 730-1 (VDE 0631 T1)**

GW ... A4            M20x1,5  
GW ... A4/2        M20x1,5

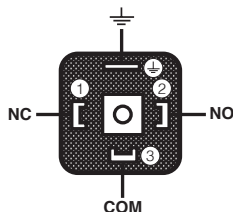

Erdung nach örtlichen Vorschriften.  
Grounding acc. local regulations.  
Mise à la terre selon normes locales.  
Messa a terra secondo prescrizioni locali.

Zur Erhöhung der Schaltleistung wird bei DC-Anwendungen < 20 mA und 24 V der Einsatz eines RC-Gliedes empfohlen.

To increase the switching capacity, we recommend that you use a RC device for current values < 20 mA and 24 V d.c. applications.

Pour augmenter la puissance de rupture, l'utilisation d'un circuit RC est préconisée pour les applications à courant continu < 20 mA et 24 V.

Per aumentare la potenza d'inserimento con applicazioni DC < 20 mA e 24 V, consigliamo l'impiego di un elemento RC.

**Schaltfunktion**  
**Switching function**  
**Schéma électrique**  
**Funzione di commutazione**  
**pressostato**  
**GW...A4, GW...A4/2**

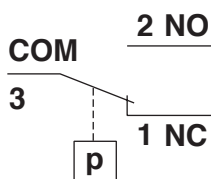

**Bei steigendem Druck:**

1 NC öffnet, 2 NO schließt.

Bei fallendem Druck:

1 NC schließt, 2 NO öffnet.

**While pressure is increasing:**

1 NC opens, 2 NO closes.

While pressure is decreasing:

1 NC closes, 2 NO opens.

**Pression montante:**

1 NC ouvre, 2 NO ferme.

Pression descendante:

1 NC ferme, 2 NO ouvre

**Con pressione in salita:**

1 NC apre, 2 NO chiude.

Con pressione in discesa:

1 NC chiude, 2 NO apre

**Einstellung des Druckwächters**  
Haube mit geeignetem Werkzeug demontieren, Schraubendreher No. 3 bzw. PZ 2, Bild 1. Haube abnehmen.

**⚠ Berührungsschutz ist nicht grundsätzlich gewährt, Kontakt mit spannungsführenden Teilen möglich.**

Druckwächter am Einstellrad mit Skala **■** auf vorgeschriebenen Drucksollwert einstellen, Bild 2.

**Anleitung des Brennerherstellers beachten!**

Druckwächter schaltet bei steigendem Druck: Einstellung auf die linke Begrenzungslinie **↑■**.

Druckwächter schaltet bei fallendem Druck: Einstellung auf die rechte Begrenzungslinie **■↓**.  
Haube wieder aufsetzen!

**Setting the pressure switch**

Dismount the hood using a suitable tool, e.g. screwdriver no. 3 or PZ2, Fig. 1. Remove hood.

**⚠ There is no protection against accidental contact. Contact with live parts is possible.**

Set the pressure switch at the setting wheel **■** to the specified pressure setpoint using the scale, Fig. 2.

**Follow the instructions of the burner manufacturer!**

Pressure switch switches as pressure increases: Set to left limit line **↑■**.

Pressure switch switches as pressure reduces: Set to right limit line **■↓**.  
Remount hood!

**Réglage des pressostats**

Enlever les vis du capot en utilisant un tournevis N°3. ou PZ 2, Fig 1. Enlever le capot.

**⚠ La protection n'est pas garantie, contact avec des pièces sous tension possible.**

Régler le pressostat avec son bouton gradué **■** à la valeur désirée, Fig. 2.

**Respecter les recommandations du constructeur du brûleur!**

Le pressostat commute par pression montante: régler sur la ligne de limitation gauche **↑■**.

Le pressostat commute par pression descendante: régler sur la ligne de limitation droite **■↓**.  
Remonter le capot!

**Regolazione del pressostato**

Smontare la calotta con un attrezzo adeguato, ossia cacciavite nr. 3, PZ 2, figura 1 Togliere la calotta.

**⚠ Non é sostanzialmente garantita la protezione da scariche, é possibile il contatto con conduttori di tensione.**

Tarare il pressostato, come in figura 2, sul valore di pressione nominale prescritto, agendo sulla rotella della scala graduata **■**.

**Prestare attenzione alle prescrizioni del produttore del bruciatore!**

Il pressostato scatta con pressione in salita: regolazione sulla linea di delimitazione sinistra **↑■**. Il pressostato scatta con pressione in discesa: regolazione sulla linea di delimitazione destra **■↓**. Rimontare la calotta!

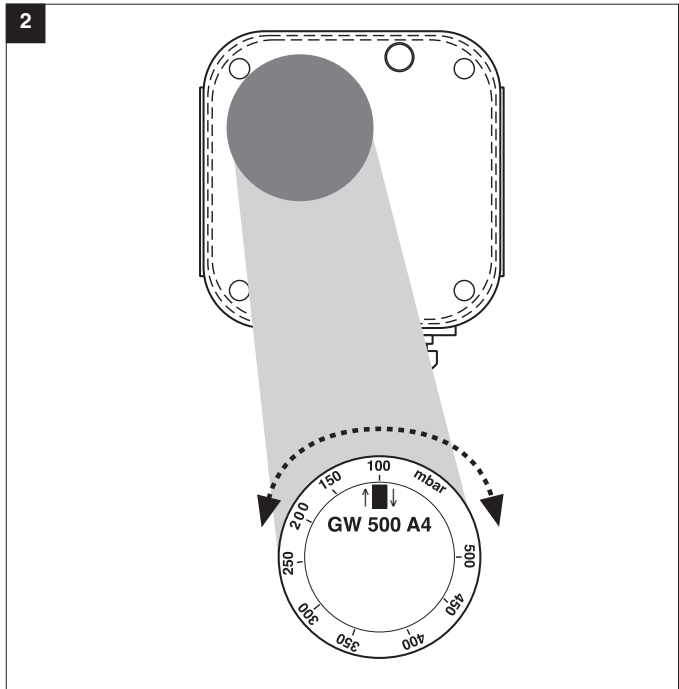
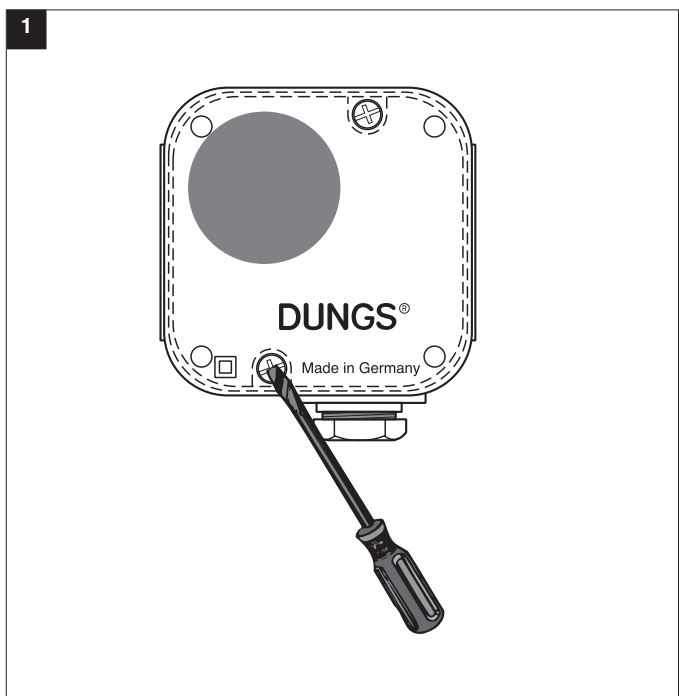

Ersatzteile / Zubehör Spare parts / Accessories Pièces de rechange / access. Parti di ricambio / Accessori	Bestell-Nummer Ordering No. No. de commande Codice articolo
Set: Gerätestecker G3, 3-pol + E für GW...A4 Kit: G3 equipment plug, 3-pin + E for GW...A4 Kit: Connecteur d'appareil G3, 3 pôles + E pour GW...A4 Set composto da: Spina G3 a 3 poli + terra	219 659
Leitungsdozen 3-pol + E, grau GDMW für GW...A4, A4/2 Line sockets, 3-pin + E grey GDMW for GW...A4, A4/2 Prises 3 pôles + T, gris GDMW pour GW...A4, A4/2 Presa a 3 poli + terra, grigia GDMW a GW...A4, A4/2	210 318

Ersatzteile / Zubehör Spare parts / Accessories Pièces de rechange / access. Parti di ricambio / Accessori	Bestell-Nummer Ordering No. No. de commande Codice articolo						
Montage-Set Glimmlampen Neon glow lamp assembly set Lampes fluorescentes, kit de montage Set die montaggio lampadina a bagliore grün/green/verte/verde	<table border="1"> <tr> <td>230 V</td> <td>24 V</td> </tr> <tr> <td>248 239</td> <td>248 240</td> </tr> </table>	230 V	24 V	248 239	248 240		
230 V	24 V						
248 239	248 240						
Montage-Set Glimmlampen Neon glow lamp assembly set Lampes fluorescentes, kit de montage Set die montaggio lampadina a bagliore gelb/yellow/jaune/giallo	<table border="1"> <tr> <td>230 V</td> <td>120 V</td> <td>24 V</td> </tr> <tr> <td>231 773</td> <td>231 772</td> <td>231 774</td> </tr> </table>	230 V	120 V	24 V	231 773	231 772	231 774
230 V	120 V	24 V					
231 773	231 772	231 774					





Arbeiten am Druckwächter dürfen nur von Fachpersonal durchgeführt werden.

Work on the pressure switch may only be performed by specialist staff.

Seul du personnel spécialisé peut effectuer des travaux sur le pressostat.

Qualsiasi operazione effettuata sul pressostato deve essere fatta da parte di personale competente.



Kondensat darf nicht in das Gerät gelangen. Bei Minustemperaturen, durch Vereisung Fehlfunktion/Ausfall möglich.

Do not allow condensate to flow into the equipment. In case of sub-zero temperatures, malfunction or equipment failure may be possible due to icing.

Eviter l'entrée de condensats dans le pressostat, une prise en glace par température négative nuirait à son fonctionnement.

Nell' apparecchio non deve infiltrarsi alcuna condensa. Alle temperature negative sarebbero possibili disfunzioni dovute a formazione di ghiaccio.

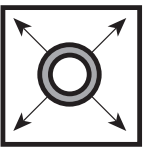

Rohrleitungsdichtheitsprüfung: Kugelhahn vor dem Druckwächter schließen.

Pipeline leakage test: close ball valve upstream of the pressure switch.

Contrôle de l'étanchéité de la conduite: fermer le robinet à boisseau sphérique avant le pressostat.

Per la prova di tenuta delle tubature: chiudere il rubinetto a sfera davanti al corpo pressostato.



Nach Abschluß von Arbeiten am Druckwächter: Dichtheitskontrolle und Funktionskontrolle durchführen.

On completion of work on the pressure switch, perform a leakage and function test.

Une fois les travaux sur le pressostat terminés, procéder toujours à un contrôle d'étanchéité et de fonctionnement.

Al termine dei lavori effettuati su un pressostato: predisporre un controllo sia della tenuta che del funzionamento.

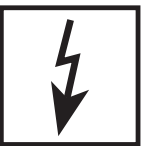

Niemals Arbeiten durchführen, wenn Gasdruck oder Spannung anliegt. Offenes Feuer vermeiden. Örtliche Vorschriften beachten.

Never perform work if gas pressure or power is applied. No naked flame. Observe local regulations.

Ne jamais effectuer des travaux sous pression et sous tension. Eviter toute flamme ouverte. Observer les réglementations.

In nessun caso si debbono effettuare lavori in presenza di pressione gas o di tensione elettrica. Evitare i fuochi aperti e osservare le prescrizioni di sicurezza locali.



Bei Nichtbeachtung der Hinweise sind Personen- oder Sachfolgeschäden denkbar.

If these instructions are not heeded, the result may be personal injury or damage to property.

En cas de non-respect de ces instructions, des dommages corporels ou matériels sont possible.

La non osservanza di quanto suddetto può implicare danni a persone o cose.



Silikonöle und flüchtige Silikonbestandteile (Siloxane) in der Umgebung vermeiden. Fehlfunktion / Ausfall möglich.

Avoid silicone oils and volatile silicones (siloxanes) in the environment. Malfunction/failure possible.

Eviter les huiles de silicone et les éléments de silicone volatils (siloxanes) dans l'environnement. Dysfonctionnement / panne possibles.

Evitare oli silconici e componenti silconici volatili (silossani) nell'ambiente. Possibile disfunzione / guasto.



Alle Einstellungen und Einstellwerte nur in Übereinstimmung mit der Betriebsanleitung des Kessel-/Brennerherstellers ausführen.

Any adjustment and application-specific adjustment values must be made in accordance with the appliance-/boiler manufacturers instructions.

Effectuer tous les réglages et réaliser les valeurs de réglage uniquement selon le mode d'emploi du fabricant de chaudières et de brûleurs.

Realizzare tutte le impostazioni e i valori impostati solo in conformità alle istruzioni per l'uso del costruttore della caldaia/ del bruciatore.



Die Druckgeräterichtlinie (PED) und die Richtlinie über die Gesamtenergieeffizienz von Gebäuden (EPBD) fordern eine regelmäßige Überprüfung der Wärmeerzeuger zur langfristigen Sicherstellung von hohen Nutzungsgraden und somit geringster Umweltbelastung.

**Es besteht die Notwendigkeit sicherheitsrelevante Komponenten nach Erreichen ihrer Nutzungsdauer auszutauschen:**

The Pressure Equipment Directive (PED) and the Energy Performance of Buildings Directive (EPBD) require a periodic inspection of heat generators in order to ensure a high degree of efficiency over a long term and, consequently, the least environmental pollution.

**It is necessary to replace safety-relevant components after they have reached the end of their useful life:**

La directive équipements sous pression (PED) et la directive sur la performance énergétique des bâtiments (EPBD) exigent une vérification régulière des générateurs de chaleur afin de garantir à long terme des taux d'utilisation élevés et par conséquent une charge environnementale minimum.

**Il est nécessaire de remplacer les composants relatifs à la sécurité lorsqu'ils ont atteint la fin de leur vie utile :**

La direttiva per apparecchi a pressione (PED) e la direttiva per l'efficienza dell'energia totale per edifici (EPBD), esigono il controllo regolare dei generatori di calore per la garanzia a lungo termine di un alto grado di rendimento e quindi di basso inquinamento ambientale.

**Ciò rende necessaria la sostituzione di componenti rilevanti dal punto di vista della sicurezza alla scadenza della loro durata di utilizzazione:**

Sicherheitsrelevante Komponente Safety-relevant component Composant relatif à la sécurité Componenti rilevanti per la sicurezza	Konstruktionsbedingte Lebensdauer Design-related service life Durée de vie prévue Durata di vita di progetto		Norm Standard Norme Norma	Dauerhafte Lagertemperatur Permanent storage temperature Température de stockage permanente Temperatura di stoccaggio permanente
	Zyklenzahl Operating cycles Cycle d'opération Numero di cicli di funzionamento	Jahre Years Années Anni		
Ventilprüfsysteme / Valve testing systems / Systèmes de contrôle de vanne / Sistemi di controllo valvole	250 000	10	EN 1643	0...45 °C 32...113 °F
Gas / Gas / Gaz / Gas Druckwächter / Pressure switch / Manostat / Pressostato	50 000	10	EN 1854	
Luft / Air / Air / Aria Druckwächter / Pressure switch / Manostat / Pressostato	250 000	10	EN 1854	
Gas mangelschalter / Low gas pressure switch / Pressostat gaz basse pression / Pressostato gas di minima pressione	N/A	10	EN 1854	
Feuerungsmanager / Automatic burner control / Dispositif de gestion de chauffage / Gestione bruciatore	250 000	10	EN 298 EN 230	
UV-Flammenfühler <sup>1</sup> UV flame sensor <sup>1</sup> Capteur de flammes UV <sup>1</sup> Sensore fiamma UV <sup>1</sup>	N/A	10 000 h <sup>3</sup>	---	
Gasdruckregelgeräte <sup>1</sup> Gas pressure regulators <sup>1</sup> Dispositifs de réglage de pression du gaz <sup>1</sup> Regolatori della pressione del gas <sup>1</sup>	N/A	15	EN 88-1 EN 88-2	
Gasventil mit Ventilprüfsystem <sup>2</sup> Gas valve with valve testing system <sup>2</sup> Vanne de gaz avec système de contrôle de vanne <sup>2</sup> Valvola del gas con sistema di controllo valvola <sup>2</sup>	nach erkanntem Fehler after error detection après détection d'erreur dopo segnalazione di errore		EN 1643	
Gasventil ohne Ventilprüfsystem <sup>2</sup> Gas valve without valve testing system <sup>2</sup> Vanne de gaz sans système de contrôle de vanne <sup>2</sup> Valvola del gas senza sistema di controllo valvola <sup>2</sup>	DN ≤ 25    200 000 25 < DN ≤ 80    100 000 80 < DN ≤ 150    50 000	10	EN 161	
Gas-Luft-Verbundsysteme / Gas-air ratio control system / Systèmes combinés gaz/air / Sistemi di miscelazione gas-aria	N/A	10	EN 88-1 EN 12067-2	

<sup>1</sup> Nachlassende Betriebseigenschaften wegen Alterung / Performance decrease due to ageing /  
Réduction de performance due au vieillissement / Riduzione delle prestazioni dovuta all'invecchiamento

<sup>2</sup> Gasfamilien II, III / Gas families II, III / Familles de gaz II, III / per i gas delle famiglie II, III

<sup>3</sup> Betriebsstunden / Operating hours / Heures de service / Ore di esercizio

N/A nicht anwendbar / not applicable / non applicable / non applicabile

### Lagerzeiten / Storage times / Périodes de stockage / Tempi di stoccaggio

Lagerzeiten ≤ 1 Jahr verkürzen nicht die konstruktionsbedingte Lebensdauer.

Storage time ≤ 1 year does not reduce the design-related service life.

Les périodes de stockage ≤ 1 an ne réduisent pas la durée de vie liée à la conception.

I tempi di stoccaggio ≤ 1 anno non riducono la durata di vita di progetto.

DUNGS empfiehlt eine maximale Lagerzeit von 3 Jahren.

DUNGS recommends a maximum storage time of 3 years.

DUNGS recommande une durée de stockage maximale de 3 ans.

DUNGS raccomanda un tempo massimo di stoccaggio di 3 anni.

Änderungen, die dem technischen Fortschritt dienen, vorbehalten / We reserve the right to make modifications in the course of technical development.  
Sous réserve de tout modification constituant un progrès technique / Ci riserviamo qualsiasi modifica tecnica e costruttiva

**Hausadresse**  
**Head Offices and Factory**  
**Usine et Services Administratifs**  
**Amministrazione e Stabilimento**

**Karl Dungs GmbH & Co. KG**  
**Karl-Dungs-Platz 1**  
**D-73660 Urbach, Germany**  
**Telefon +49 7181-804-0**  
**Telefax +49 7181-804-166**

**Briefadresse**  
**Postal address**  
**Adresse postale**  
**Indirizzare la corrispondenza a**

**Karl Dungs GmbH & Co. KG**  
**Postfach 12 29**  
**D-73602 Schorndorf**  
**e-mail info@dungs.com**  
**Internet www.dungs.com**



**Hausadresse**  
Head Offices and Factory  
Usine et Services Administratifs  
Amministrazione e Stabilimento

**Karl Dungs GmbH & Co. KG**  
Karl-Dungs-Platz 1  
D-73660 Urbach, Germany  
Telefon +49 7181-804-0  
Telefax +49 7181-804-166

**Briefadresse**  
Postal address  
Adresse postale  
Indirizzare la corrispondenza a

**Karl Dungs GmbH & Co. KG**  
Postfach 12 29  
D-73602 Schorndorf  
e-mail [info@dungs.com](mailto:info@dungs.com)  
Internet [www.dungs.com](http://www.dungs.com)